

QUANTM™ Pumps, Industrial Models

3A8572G

EN

Electric-operated diaphragm (EODD) pumps with an integral electric drive for fluid transfer applications. For professional use only.



Important Safety Instructions

Read all warnings and instructions in this manual and related manuals before using the equipment. Save these instructions.

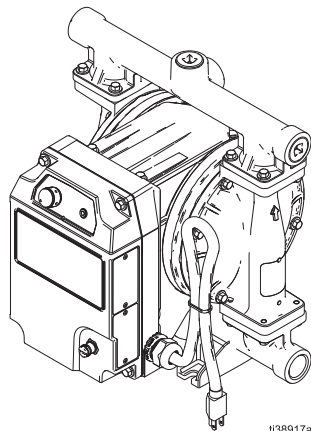

i38917a

i30 (QTC) Model

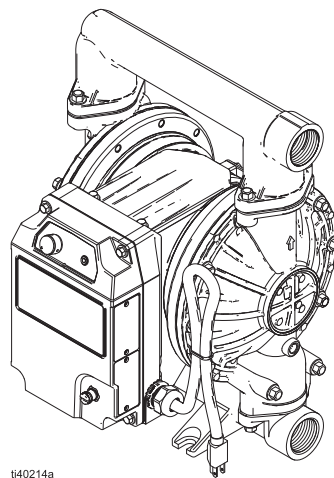

ti40214a

i80 (QTD) Model

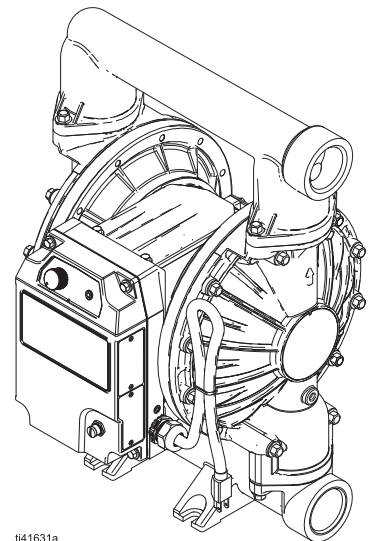

ti41631a

i120 (QTE) Model

Contents

Related Manuals	3	Repair	40
Safety Symbols	4	Prepare Equipment for Repair	40
Warnings	5	Repair the Check Valves (Ball Pumps)	41
Configuration Matrix	9	Repair the Check Valves (Flapper Pumps)	42
Approvals	12	Repair the Standard Diaphragms	43
Component Identification	13	Repair the Overmolded Diaphragms	45
Typical Installation	14	Recycling and Disposal	48
General Information	14	End of Equipment Life	48
Typical Installation for Ball Models in Ordinary Locations	14	Torque Fasteners	49
Typical Installation for Ball Models in Explosive Atmospheres or Hazardous (Classified) Locations	15	Torque Instructions	49
Typical Installation for i120 (QTE) Flapper Models in Ordinary Locations	16	Torque Sequence	49
Typical Installation for i120 (QTE) Flapper Models in Hazardous (Classified) Locations	17	Performance Charts	53
Installation	18	Performance Chart for i30 (QTC) Models	53
Mount the Pump	18	Performance Chart for i80 (QTD) Models	54
Orientation of Fluid Inlet and Outlet Ports	18	Performance Chart for i120 (QTE) Ball Models	54
Connect Fluid Lines	19	Performance Chart for i120 (QTE) Flapper Models	55
Install Accessories	20	Dimensions	56
Grounding	21	Dimensions for i30 (QTC) Models	56
Before First Use	22	Dimensions for i80 (QTD) Models	62
Electrical Connections and Wiring	23	Dimensions for i120 (QTE) Ball Models	66
Required Power and Plugs	23	Dimensions for i120 (QTE) Flapper Models	70
Wire Power Cables	24	Technical Specifications	72
Requirements for Cables and Conduits	25	Fluid Temperature Range	72
Adapters for Plugs and Cables	25	Technical Specifications for i30 (QTC) Models	74
I/O Pin Connection	26	Technical Specifications for i80 (QTD) Models	75
Operation	29	Technical Specifications for i120 (QTE) Ball Models	76
Pressure Relief Procedure	29	Technical Specifications for i120 (QTE) Flapper Models	77
Before Each Use	29	California Proposition 65	78
Start the Equipment	29	Graco Standard Warranty	80
Shut Down the Equipment	31		
LED Indicator	32		
LED Indicator Overview	32		
LED Indicator Event Errors	33		
Maintenance	35		
Lubricate the Equipment	35		
Flush the Equipment	35		
Store the Equipment	36		
Clean the Wetted Section	36		
Troubleshooting	37		







Related Manuals

English Manual Number	Description	Reference
3A7637	QUANTM Electric Motor, Repair/Parts	Repair/Parts Manual
3A8946	QUANTM Pumps, Industrial Models, Parts	Parts Manual
3A8861	QUANTM Leak Sensor, Instruction	Kit Instructions
3A8982	QUANTM I/O Cable Kit (Hazardous Locations), Instruction	Kit Instructions

Safety Symbols







The following safety symbols appear throughout this manual and on warning labels. Read the table below to understand what each symbol means.

Symbol	Meaning
	Burn Hazard
	Cleaning Solvent Hazard
	Electric Shock Hazard
	Equipment Misuse Hazard
	Fire and Explosion Hazard
	Entanglement Hazard
	Moving Parts Hazard
	Pressurized Equipment Hazard
	Splash Hazard
	Toxic Fluid or Fumes Hazard

Symbol	Meaning
	Ground Equipment
	Read Manual
	Follow Pressure Relief Procedure
	Ventilate Work Area
	Wear Personal Protective Equipment
	Do Not Wipe with a Dry Cloth
	Eliminate Ignition Sources

Warnings

The following warnings are for the setup, use, grounding, maintenance, and repair of this equipment. The exclamation point symbol alerts you to a general warning and the hazard symbols refer to procedure-specific risks. When these symbols appear in the body of this manual or on warning labels, refer back to these Warnings. Product-specific hazard symbols and warnings not covered in this section may appear throughout the body of this manual where applicable.

 WARNING	
    	<p>FIRE AND EXPLOSION HAZARD</p> <p>Flammable fumes, such as solvent and paint fumes, in work area can ignite or explode. Paint or solvent flowing through the equipment can cause static sparking. To help prevent fire and explosion:</p> <ul style="list-style-type: none"> • Use equipment only in well-ventilated area. • Eliminate all ignition sources; such as pilot lights, cigarettes, portable electric lamps, and plastic drop cloths (potential static sparking). • Ground all equipment in the work area. See Grounding instructions. • Keep work area free of debris, including solvent, rags and gasoline. • Do not plug or unplug power cords, or turn power or light switches on or off when flammable fumes are present. • Use only conductive grounded fluid lines. • Stop operation immediately if static sparking occurs or you feel a shock. Do not use equipment until you identify and correct the problem. • Keep a working fire extinguisher in the work area. <p>Static charge may build up on plastic parts during cleaning and could discharge and ignite flammable vapors. To help prevent fire and explosion:</p> <ul style="list-style-type: none"> • Clean plastic parts only in well-ventilated area. • Do not clean with a dry cloth.



WARNING

**ELECTRIC SHOCK HAZARD****Explosive Atmospheres or Hazardous (Classified) Locations Models (hard wired for permanent connection)**

This equipment must be grounded. Improper grounding, setup, or usage of the system can cause electric shock.

- Turn off and disconnect power at main switch before disconnecting any cables and before servicing or installing equipment.
- Connect only to grounded power source.
- All electrical wiring and repairs must be done by a qualified electrician and comply with all local codes and regulations.
- Store indoors.

Ordinary Locations Models (cord and plug connection)

This equipment must be grounded. Improper grounding, setup, or usage of the system can cause electric shock.

- Turn off and disconnect power cord before servicing equipment.
- Connect only to grounded electrical outlets.
- Only use 3-wire extension cords for 2-phase models. Only use 4-wire extension cords for 3-phase models.
- Ensure ground prongs are intact on power and extension cords.
- Store indoors.
- Wait five minutes after disconnecting power cord before servicing.

**EQUIPMENT MISUSE HAZARD**

Misuse can cause death or serious injury.

- Do not operate the unit when fatigued or under the influence of drugs or alcohol.
- Do not exceed the maximum working pressure or temperature rating of the lowest rated system component. See **Technical Specifications** in all equipment manuals.
- Use fluids and solvents that are compatible with equipment wetted parts. See **Technical Specifications** in all equipment manuals. Read fluid and solvent manufacturer's warnings. For complete information about your material, request Safety Data Sheets (SDSs) from distributor or retailer.
- Turn off all equipment and follow the **Pressure Relief Procedure** when equipment is not in use.
- Check equipment daily. Repair or replace worn or damaged parts immediately with genuine manufacturer's replacement parts only.
- Do not alter or modify equipment. Alterations or modifications may void agency approvals and create safety hazards.
- Make sure all equipment is rated and approved for the environment in which you are using it.
- Use equipment only for its intended purpose. Call your distributor for information.
- Route fluid lines, cords, and cables away from traffic areas, sharp edges, moving parts, and hot surfaces.
- Do not kink or over-bend fluid lines, cords, or cables. Do not use fluid lines, cords, or cables to pull equipment.
- Keep children and animals away from work area.
- Comply with all applicable safety regulations.





WARNING

**PLASTIC PARTS CLEANING SOLVENT HAZARD**

Many cleaning solvents can degrade plastic parts and cause them to fail, which could cause serious injury or property damage.

- Use only compatible solvents to clean plastic structural or pressure-containing parts.
- See **Technical Specifications** in all equipment manuals for materials of construction. Consult the solvent manufacturer for information and recommendations about compatibility.

**PRESSURIZED EQUIPMENT HAZARD**

Fluid from the equipment, leaks, or ruptured components can splash in the eyes or on skin and cause serious injury.

- Follow the **Pressure Relief Procedure** when you stop spraying/dispensing and before cleaning, checking, or servicing equipment.
- Tighten all fluid connections before operating the equipment.
- Check fluid lines and connections daily. Replace worn or damaged parts immediately.

**PRESSURIZED ALUMINUM PARTS HAZARD**

Use of fluids that are incompatible with aluminum in pressurized equipment can cause serious chemical reaction and equipment rupture. Failure to follow this warning can result in death, serious injury, or property damage.

- Do not use 1,1,1-trichloroethane, methylene chloride, other halogenated hydrocarbon solvents or fluids containing such solvents.
- Do not use chlorine bleach.
- Many other fluids may contain chemicals that can react with aluminum. Contact your material supplier for compatibility.

**THERMAL EXPANSION HAZARD**





Fluids subjected to heat in confined spaces, including fluid lines, can create a rapid rise in pressure due to the thermal expansion. Over-pressurization can result in equipment rupture and serious injury.

- Open a valve to relieve the fluid expansion during heating.
- Replace fluid lines proactively at regular intervals based on your operating conditions.

**TOXIC FLUID OR FUMES HAZARD**

Toxic fluids or fumes can cause serious injury or death if splashed in the eyes or on skin, inhaled, or swallowed.

- Read Safety Data Sheets (SDSs) to know the specific hazards of the fluids you are using.
- Store hazardous fluid in approved containers, and dispose of it according to applicable guidelines.

 <h1 style="margin: 0;">WARNING</h1>	
	<p>BURN HAZARD</p> <p>Equipment surfaces and fluid that is heated can become very hot during operation. To avoid severe burns:</p> <ul style="list-style-type: none"> • Do not touch hot fluid or equipment.
	<p>PERSONAL PROTECTIVE EQUIPMENT</p> <p>Wear appropriate protective equipment when in the work area to help prevent serious injury, including eye injury, hearing loss, inhalation of toxic fumes, and burns. Protective equipment includes but is not limited to:</p> <ul style="list-style-type: none"> • Protective eyewear, and hearing protection. • Respirators, protective clothing, and gloves as recommended by the fluid and solvent manufacturer.
 	<p>ENTANGLEMENT HAZARD</p> <p>Rotating parts can cause serious injury.</p> <ul style="list-style-type: none"> • Keep clear of moving parts. • Do not operate equipment with protective guards or covers removed. • Do not wear loose clothing, jewelry or long hair while operating equipment. • Equipment can start without warning. Before checking, moving, or servicing equipment, follow the Pressure Relief Procedure and disconnect all power sources.

Configuration Matrix

Record the model part number and configuration sequence found on your equipment identification plate (ID) to assist you when ordering replacement parts.

Model Part Number:

Configuration Sequence:

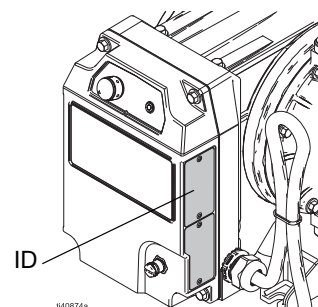

Sample Configuration Sequence: QTC-ACFC2ACACBNBNA100										
Q	T	C	AC	FC2	AC	AC	BN	BN	A1	00
Brand	Application	Model	Wetted Section Material	Motor	Seat Material	Check Material	Diaphragm Material	Manifold Seal Material	Connection	Options

NOTE: Some combinations are not possible. Check with your local distributor.

Brand		Application		Model		Wetted Section Material	
Q	QUANTM	T	Industrial (i)	C	30 (1 in. port)	AL	Aluminum
				D	80 (1-1/2 in. port)	CI	Cast Iron
				E	120 (2 in. port)	CP	Conductive Polypropylene
						PP	Polypropylene
						PV	PVDF
						SS	316 Stainless Steel

Motor - Industrial Models						
Drive		Coat	Input Voltage	Phase	Location	Cord/Cable Termination
FC1*	Aluminum Direct Drive	Black powder coat	200-240 V	3-Phase	Industrial, Ordinary Locations	Cord with plug
FC2	Aluminum Direct Drive	Black powder coat	200-240 V	Single-Phase	Industrial, Ordinary Locations	Cord with plug
FC3*	Aluminum Direct Drive	Black powder coat	200-240 V	3-Phase	Industrial, Explosive Atmospheres	Cord with flying leads
FC4	Aluminum Direct Drive	Black powder coat	200-240 V	Single-Phase	Industrial, Explosive Atmospheres	Cable with flying leads
FC5	Aluminum Direct Drive	Black powder coat	100-120 V	Single-Phase	Industrial, Ordinary Locations	Cord with plug
FC6	Aluminum Direct Drive	Black powder coat	100-120 V	Single-Phase	Industrial, Hazardous (Classified) Locations	Cable with flying leads

Configuration Matrix

Motor - Industrial Models						
Drive		Coat	Input Voltage	Phase	Location	Cord/Cable Termination
FE1*	Aluminum Direct Drive	FEP coat	200-240 V	3-Phase	Industrial, Ordinary Locations, Enhanced (Chemical)	Cord with plug
FE2	Aluminum Direct Drive	FEP coat	200-240 V	Single-Phase	Industrial, Ordinary Locations, Enhanced (Chemical)	Cord with plug
FE3*	Aluminum Direct Drive	FEP coat	200-240 V	3-Phase	Industrial, Explosive Atmospheres, Enhanced (Chemical)	Cord with flying leads
FE4	Aluminum Direct Drive	FEP coat	200-240 V	Single-Phase	Industrial, Explosive Atmospheres, Enhanced (Chemical)	Cable with flying leads
FE5	Aluminum Direct Drive	FEP coat	100-120 V	Single-Phase	Industrial, Ordinary Locations, Enhanced (Chemical)	Cord with plug
FE6	Aluminum Direct Drive	FEP coat	100-120 V	Single-Phase	Industrial, Hazardous (Classified) Locations, Enhanced (Chemical)	Cable with flying leads

*Not available with i30 (QTC).



Seat Material		Check Material		Diaphragm Material		Manifold Seal Material	
AC	Acetal	AC	Acetal, ball	BN	Buna-N	--	None
AL	Aluminum	-B	Buna-N Overmold 303 Stainless Steel, flapper	CO	Polychloroprene Overmold	BN	Buna-N
BN*	Buna-N	BN	Buna-N, ball	CR	Polychloroprene	PT	PTFE
FB	303 Stainless Steel with Buna-N seals	CR	Polychloroprene, standard, ball	FK	Fluoroelastomer		
FK*	Fluoroelastomer	CW	Polychloroprene, weighted, ball	GE	Graco Engineered Thermoplastic		
GE	Graco Engineered Thermoplastic	FK	Fluoroelastomer, ball	PO	PTFE/EPDM Overmold		
PP	Polypropylene	GE	Graco Engineered Thermoplastic, ball	PS	PTFE/Santoprene, two-piece		
PV	PVDF	PT	PTFE/EPDM, 2-piece	SP	Santoprene		
SA	17-4PH Stainless Steel with PTFE o-rings	SD	440C Stainless Steel, ball	TP	TPE		
SP	Santoprene	SP	Santoprene, ball				
SS	316 Stainless Steel	SS	316 Stainless Steel, ball				
TP*	TPE	TP	TPE, ball				

* Models with BN, FK, or TP seats do not use manifold seals.

Connection		Options	
A1	Aluminum, standard ports, NPT	00	Standard
A2	Aluminum, standard ports, BSPT	LP	Large particle
C1	Conductive Polypropylene, center flange		
C2	Conductive Polypropylene, end flange		
F1	PVDF, center flange		
F2	PVDF, end flange		
I1	Iron, standard ports, NPT		
I2	Iron, standard ports, BSP		
P1	Polypropylene, center flange		
P2	Polypropylene, end flange		
S1	Stainless Steel, standard ports, NPT		
S2	Stainless Steel, standard ports, BSPT		
S51	Stainless Steel, center flange, horizontal outlet		

Motor Drive Selection			
Industrial - North America			
Model	Ordinary Location (NEMA Plug)	Hazardous Location (Flying Leads)	Voltage range/phase count
i30 (QTC)	FC5	FC6	100/120V/Single-Phase
i80 (QTD)	FC1	FC3	200/240V/3-Phase
i120 (QTE)	FC1	FC3	200/240V/3-Phase
Industrial - International			
Model	Ordinary Location (IEC Plug)	Hazardous Location (Flying Leads)	Voltage range/phase count
i30 (QTC)	FC2	FC4	200/240V/Single-Phase
i80 (QTD)	FC2	FC4	200/240V/Single-Phase
i120 (QTE)	FC2	FC4	200/240V/Single-Phase
Industrial - Enhanced (Chemical) - North America			
Model	Ordinary Location (NEMA Plug)	Hazardous Location (Flying Leads)	Voltage range/phase count
i30 (QTC)	FE5	FE6	100/120V/Single-Phase
i80 (QTD)	FE1	FE3	200/240V/3-Phase
i120 (QTE)	FE1	FE3	200/240V/3-Phase
Industrial - Enhanced (Chemical) - International			
Model	Ordinary Location (IEC Plug)	Hazardous Location (Flying Leads)	Voltage range/phase count
i30 (QTC)	FE2	FE4	200/240V/Single-Phase
i80 (QTD)	FE2	FE4	200/240V/Single-Phase
i120 (QTE)	FE2	FE4	200/240V/Single-Phase

Approvals

Model Information*	Approvals
Motors	For motor approvals, see your related motor manual. See Related Manuals , page 3.
Pump models with motor code FC2*:	
Pump models with motor code FC4*:	  <p data-bbox="1052 741 1247 793">II 2 G Ex db h IIB T4 Gb</p> <p data-bbox="1052 800 1446 850">NOTE: Type of Protection “h” applied is constructional safety “c.”</p>

* See **Configuration Matrix**, starting on page 9, for detailed descriptions.

Component Identification

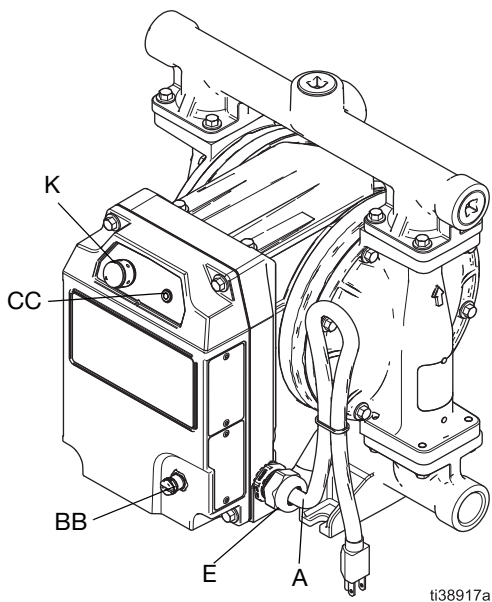

ti38917a

FIG. 1: Ordinary Locations Model (i30 (QTC) model shown)
 Ordinary Locations models include a cord with a plug and Input/Output (I/O) port.

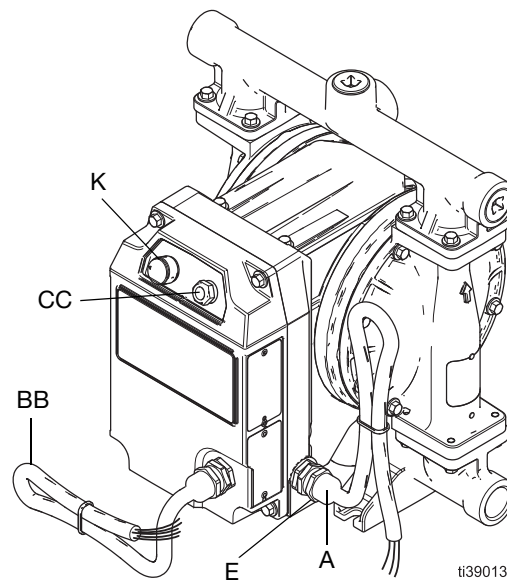

ti39013a

FIG. 2: Explosive Atmospheres or Hazardous (Classified) Locations Model (i30 (QTC) model shown)
 Explosive Atmospheres or Hazardous (Classified) Locations models include flying leads on the power cable (for direct wiring to a power source).

Ref.	Component	Ordinary Locations Models	Explosive Atmospheres or Hazardous (Classified) Locations Models
A	Power Cord/Cable	15 ft (4.6 m) cord with plug*	15 ft (4.6 m) cable for hard-wiring†
BB	I/O Port/Cable	M12, 5-pin connector**	Cable (not supplied) for direct wiring to user-provided controls‡
	On/Off Control, Digital Input		
	Run Status, Digital Output		
CC	LED Indicator♦	Standard	Reinforced
	External Ground Fastener, Ground Symbol	The equipment is marked per IEC 417, Symbol 5019: 	
K	Control Knob	Turn clockwise (right) to increase fluid output	

* See **Required Power and Plugs**, page 23.

** See **I/O Pin Connection**, page 26.

† See **Wire Power Cables**, page 24, and : **Wiring for 3-Phase Models**, page 24.

‡ I/O cable kits are available (purchase separately). See your related motor manual. See **Related Manuals**, page 3.

♦ See **LED Indicator**, page 32.

Typical Installation

General Information

Typical installations are shown for ball and flapper model pumps in ordinary and hazardous locations. The figures are only guides for selecting and installing system components. Contact your local distributor for assistance in planning a system to suit your needs.

Always use Genuine Graco Parts and accessories. Be sure all accessories are adequately sized and pressure-rated to meet the requirements of the system.

Reference letters in the text, for example, (A), refer to the callouts in the figures.

Typical Installation for Ball Models in Ordinary Locations

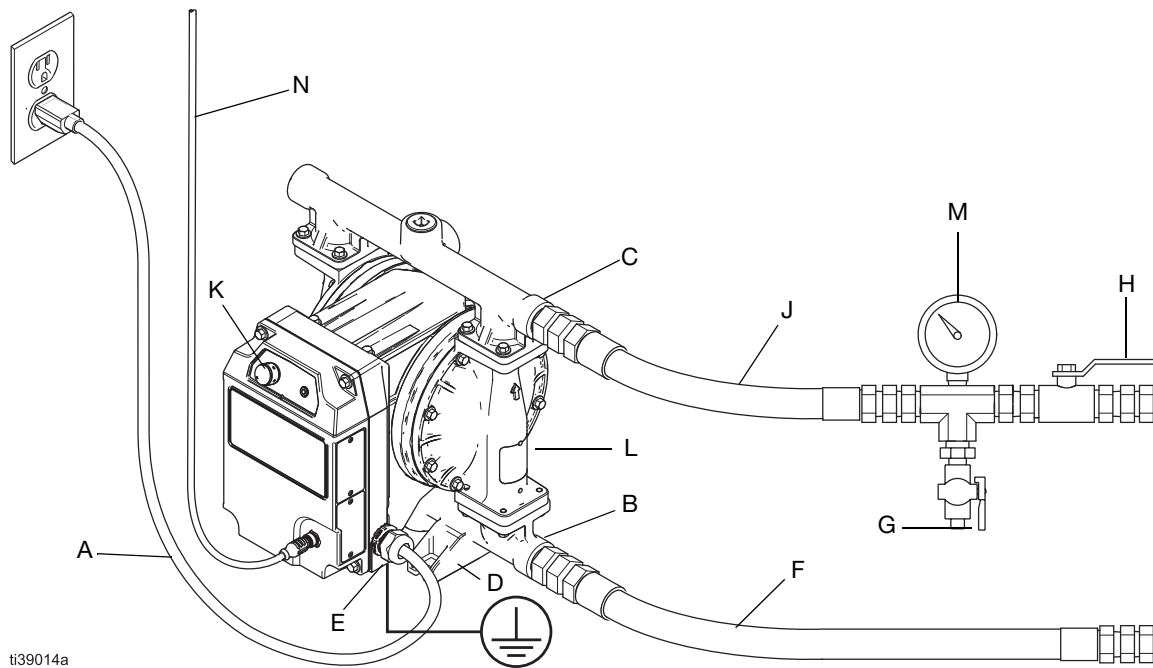

i39014a

FIG. 3: Typical Installation for Models in Ordinary Locations (cord and plug connection) (i30 (QTC) model shown)

Pump Components	Accessories (Not Supplied)
A ♦ Power cord	F* Conductive, flexible fluid supply line
B Fluid inlet port	G* Fluid drain valve
C Fluid outlet port	H Fluid shutoff valve
D Mounting feet	J* Conductive, flexible fluid outlet line
E Ground fastener	M Fluid pressure gauge
K Fluid output control knob	N I/O Cable
L ▼ Diaphragm access ports (not shown)	
♦ Connect to a circuit with a main electrical disconnect. Install a branch circuit protective device in each ungrounded phase. Follow local codes and regulations.	* Required, not supplied.
▼ See Install Leak Sensor Hoses and Fittings , page 20, or Install Fluid Leak Line Accessories , page 20.	

Typical Installation for Ball Models in Explosive Atmospheres or Hazardous (Classified) Locations

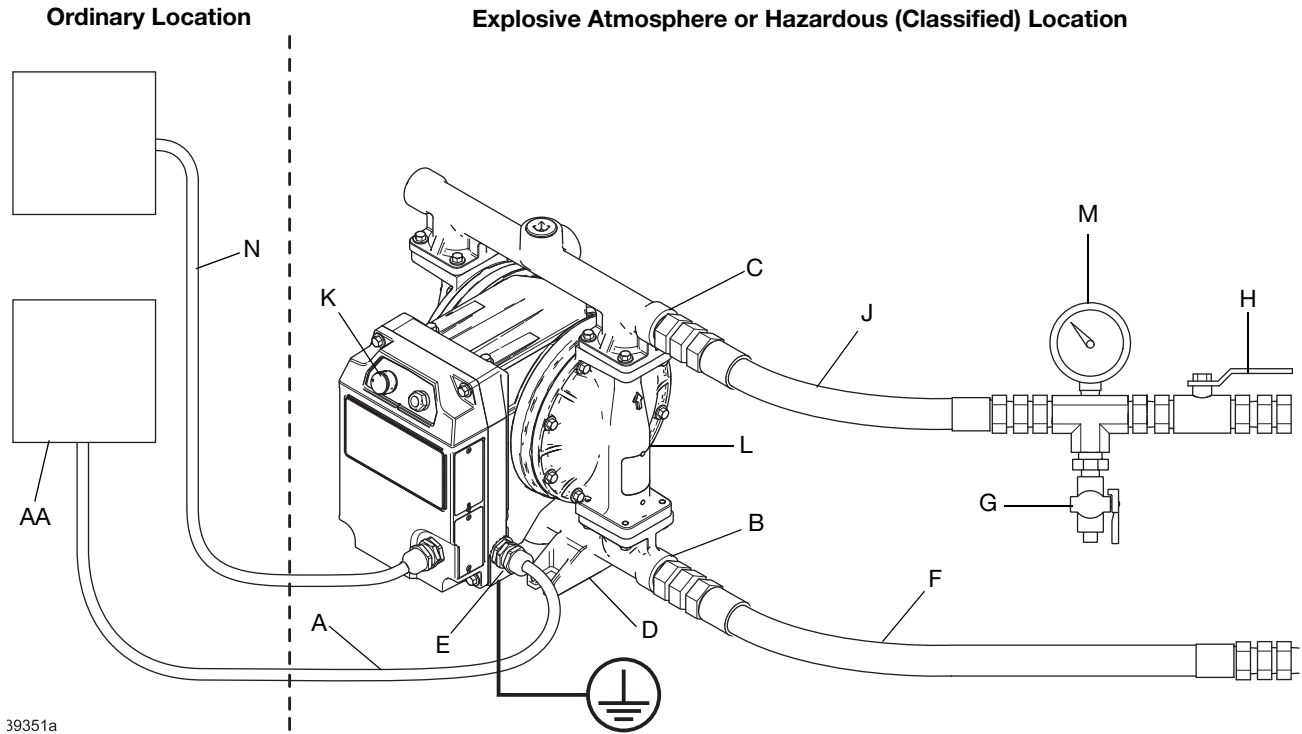

39351a

FIG. 4: Typical Installation for Models in Explosive Atmospheres or Hazardous (Classified) Locations (hard wired for permanent connection) (i30 (QTC) model shown)

Pump Components

- A** ♦ Power cable
- B** Fluid inlet port
- C** Fluid outlet port
- D** Mounting feet
- E** Ground fastener
- K** Fluid output control knob
- L** ▼ Diaphragm access ports (not shown). Diaphragm access ports must not be open in hazardous locations. Ports must have installed either plugs 128658 (as shipped from the factory), or leak sensor kit 25F109.

♦ Connect to a circuit with a main electrical disconnect. Install a branch circuit protective device in each ungrounded phase. Follow local codes and regulations.

▼ See **Install Leak Sensor Hoses and Fittings**, page 20, or **Install Fluid Leak Line Accessories**, page 20.

Accessories (Not Supplied)

- F*** Conductive, flexible fluid supply line
- G*** Fluid drain valve
- H** Fluid shutoff valve
- J*** Conductive, flexible fluid outlet line
- M** Fluid pressure gauge
- N*‡** I/O Cable
- AA** Electrical disconnect

* Required, not supplied.

‡ I/O cable kits are available (purchase separately). See your related motor manual. See **Related Manuals**, page 3.

Typical Installation for i120 (QTE) Flapper Models in Ordinary Locations

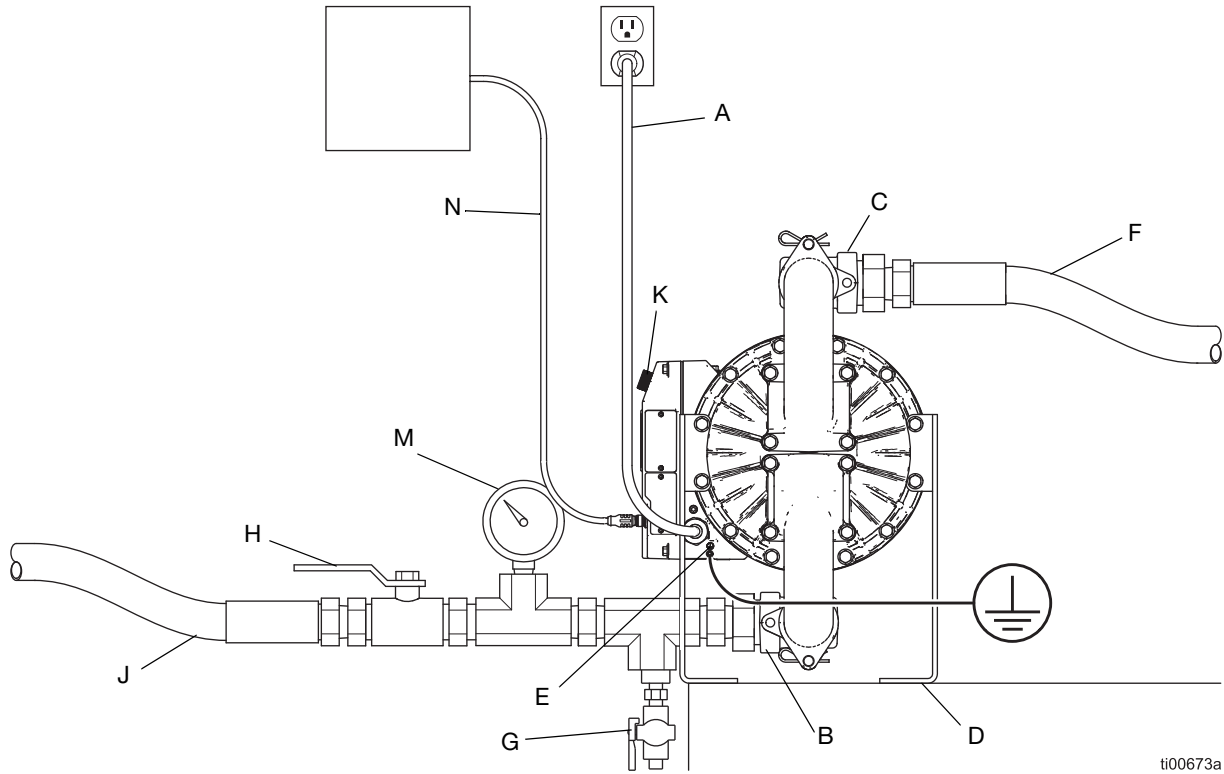

ti00673a

FIG. 5: Typical Installation for i120 (QTE) Flapper Models in Ordinary Locations (cord and plug connection)

Pump Components

- A**♦ Power cord
 - B** Fluid outlet port
 - C** Fluid inlet port
 - D** Mounting feet
 - E** Ground fastener
 - K** Fluid output control knob
 - L**▼ Diaphragm access ports (not shown)
- ♦ Connect to a circuit with a main electrical disconnect. Install a branch circuit protective device in each ungrounded phase. Follow local codes and regulations.
- ▼ See **Install Leak Sensor Hoses and Fittings**, page 20, or **Install Fluid Leak Line Accessories**, page 20.

Accessories (Not Supplied)

- F*** Conductive, flexible fluid supply line
 - G*** Fluid drain valve
 - H** Fluid shutoff valve
 - J*** Conductive, flexible fluid outlet line
 - M** Fluid pressure gauge
 - N** I/O Cable
- * Required, not supplied.

Typical Installation for i120 (QTE) Flapper Models in Hazardous (Classified) Locations

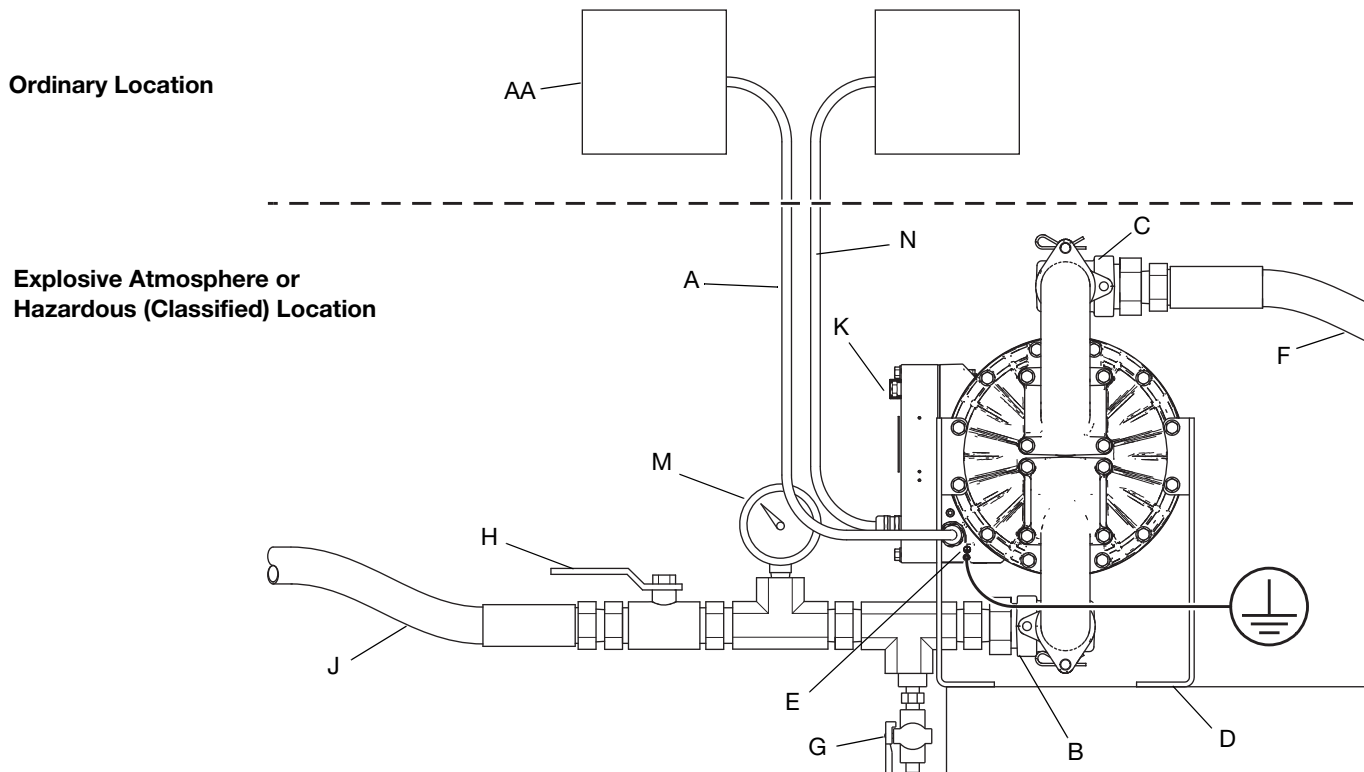

FIG. 6: Typical Installation for i120 (QTE) Flapper Models in Explosive Atmospheres or Hazardous (Classified) Locations (hard wired for permanent connection)

Pump Components

- A♦ Power cable
- B Fluid outlet port
- C Fluid inlet port
- D Mounting feet
- E Ground fastener
- K Fluid output control knob
- L▼ Diaphragm access ports (not shown). Diaphragm access ports must not be open in hazardous locations. Ports must have installed either plugs 128658 (as shipped from the factory), or leak sensor kit 25F109.

♦ Connect to a circuit with a main electrical disconnect. Install a branch circuit protective device in each ungrounded phase. Follow local codes and regulations.

▼ See *Install Leak Sensor Hoses and Fittings*, page 20, or *Install Fluid Leak Line Accessories*, page 20.

Accessories (Not Supplied)

- F* Conductive, flexible fluid supply line
- G* Fluid drain valve
- H Fluid shutoff valve
- J* Conductive, flexible fluid outlet line
- M Fluid pressure gauge
- N*‡ I/O Cable
- AA Electrical disconnect

* Required, not supplied.

‡ I/O cable kits are available (purchase separately). See your related motor manual. See **Related Manuals**, page 3.

Installation



Installation of this equipment involves potentially hazardous procedures. Only trained and qualified personnel who have read and who understand the information in this manual should install this equipment.

To avoid injury from fire, explosion, or electric shock, all electrical wiring must be done by a qualified electrician and comply with all local codes and regulations.

Mount the Pump



The pump may be very heavy (see **Technical Specifications**, starting on page 72, for specific weights). Use at least two straps to evenly support the bottom of the pump, and appropriate lifting equipment, or have two people lift the pump. Do not use the upper manifold or port (C) alone to lift the pump.

Mount the pump to the mounting surface using fasteners through each hole of the feet. See FIG. 7.

1. Ensure that the mounting surface is level.
2. Ensure that the mounting surface and mounting hardware is strong enough to support the weight of the pump, fluid lines, accessories, and fluid, as well as the stress caused during operation.
3. For all mountings, be sure the pump is secured with fasteners through the mounting holes on the base. See FIG. 7. See **Dimensions**, starting on page 56.

NOTE: For ease of operation and service, mount the pump so the control knob (K), LED indicator (CC), I/O port/cable (BB), and fluid inlet and outlet ports (B, C) are easily accessible.

NOTICE

To avoid pump damage, mount the pump to the mounting surface using fasteners through each hole of the feet. See FIG. 7.

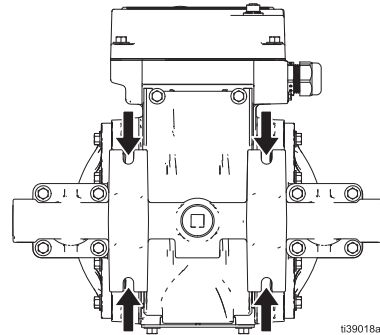

FIG. 7: Mounting Holes

Orientation of Fluid Inlet and Outlet Ports

The fluid port of the center manifold can be rotated to either a vertical or horizontal position.

To change the fluid port orientation of the center manifold (54):

1. Remove the clevis and cotter pins (35, 36).
2. Rotate the center manifold (54) to the applicable vertical or horizontal position.
3. Install the clevis and cotter pins (35, 36).

KEY:

- 3 Fluid covers
- 54 Center manifold
- 35 Clevis pin
- 36 Cotter pin

NOTE: Install the equipment as close as possible to the material source. See **Technical Specifications**, starting on page 72, for maximum suction lift.

NOTICE

The pump can be damaged if flexible fluid lines are not used. If hard-plumbed fluid lines are used in the system, use a short length of conductive, flexible fluid line to connect to the pump.

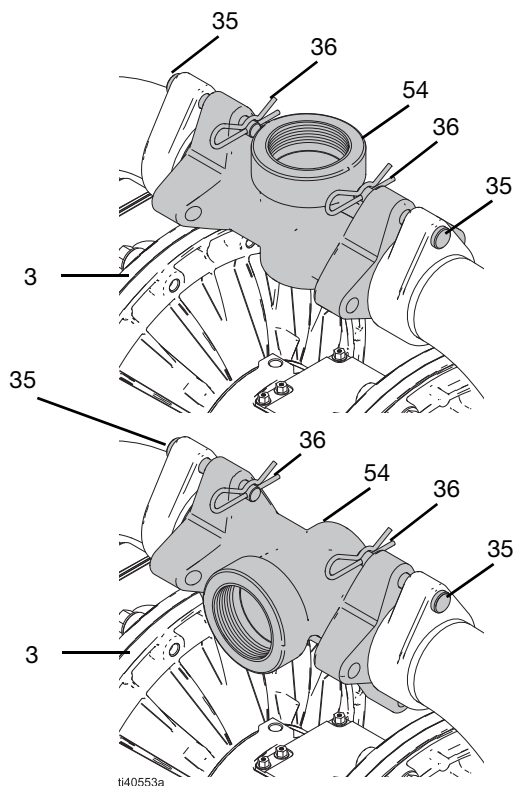

FIG. 8: Fluid Inlet and Outlet Port Orientation

Connect Fluid Lines

Use conductive, flexible fluid lines for fluid supply (F) and fluid outlet (J) lines.

NOTE: For proper priming, ensure the fluid outlet port (C) is mounted higher than the fluid inlet port (B). See FIG. 3 and FIG. 4.

1. Install conductive, flexible fluid lines (F and J).
2. Install a fluid drain valve (G) near the fluid outlet. See FIG. 3 and FIG. 4.



A fluid drain valve (G) is required to relieve pressure in the fluid outlet line. The drain valve reduces the risk of serious injury, including splashing in the eyes or on the skin, when relieving pressure.

3. Install a fluid shutoff valve (H) in the fluid outlet line (J) downstream from the fluid drain valve (G).

Install Accessories

Install Leak Sensor Hoses and Fittings

The leak sensor monitors for leaks in the pump due to diaphragm rupture or other leaks in the equipment. If the sensor detects a leak, the LED indicator on the pump will flash and the pump will stop.

The leak sensor is installed in certain models at the factory or by the distributor. A leak sensor kit is available for initial installation or replacement. See the electric motor manual for Accessory Kits. See **Related Manuals**, page 3.

For models with a factory-installed leak sensor, you must install the external hoses and fittings before using the pump for the first time. See the Leak Sensor Instructions manual for instructions. See **Related Manuals**, page 3.

NOTICE

To avoid pump damage, install a leak sensor to detect leaks in the equipment due to diaphragm rupture.

Install Fluid Line Accessories

Install the following accessories in the order shown in FIG. 3 and FIG. 4, using adapters as needed.

- **Fluid drain valve (G):** Required. Relieves fluid pressure in the system.
- **Fluid shutoff valve (H):** Shuts off fluid flow.
- **Fluid pressure gauge (M):** For more precise adjustment of the fluid pressure.
- **Fluid outlet line (J):** Required. To dispense fluid.
- **Fluid supply line (F):** Required. Enables the equipment to draw fluid from a container.

Install Fluid Leak Line Accessories



If a leak sensor is not installed in the pump and the diaphragm ruptures, the equipment will fill with fluid or fluid will drain into the work area. To avoid injury from leaking fluid, toxic fluid, toxic fumes, splashing fluid, or hot fluid, install fluid leak lines to route fluid leaks due to diaphragm rupture.

NOTICE

To avoid pump damage due to diaphragm rupture, install a leak sensor to detect leaks in the equipment and automatically stop pump operation. See **Install Leak Sensor Hoses and Fittings**, page 20.

The fluid leak line (L2) routes fluid to a drain location if fluid leaks due to diaphragm rupture.

1. Remove the plugs (if applicable) in the diaphragm access ports (L).
2. Install conductive, flexible fluid leak lines (L2) to the diaphragm access ports (L). Use adapters as needed.
3. Route the fluid leak lines (L2) to a grounded end container (L3) to catch leaking fluid. Follow local codes and regulations for grounding.



For Models in Explosive Atmospheres or Hazardous (Classified) Locations) without a leak sensor: To avoid injury from hazardous fluids, ensure that the end container is grounded and located in a non-explosive or non-hazardous environment. Diaphragm access ports must not be open in hazardous locations. Ports must have installed either plugs 128658 (as shipped from the factory), or leak sensor kit 25F109.

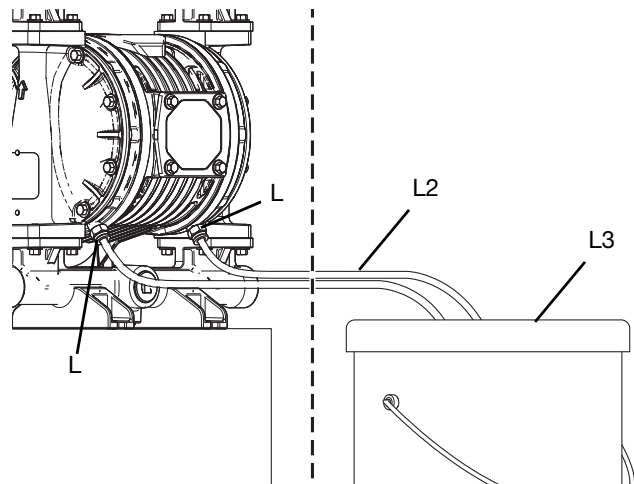





Fig. 9: Typical Installation of Fluid Leak Lines (Ordinary Locations)

Grounding

				
<p>The equipment must be grounded to reduce the risk of static sparking and electric shock. Electric or static sparking can cause fumes to ignite or explode. Improper grounding can cause electric shock. Grounding provides an escape wire for the electric current.</p> <ul style="list-style-type: none"> • Always ground the entire fluid system as described in this section. • Follow local codes and regulations. 				

Before operating the equipment, ground the system as follows.

Ground the Pump

Connect a Static Ground

See FIG. 10.

1. Loosen the ground fastener (E).
2. Insert one end of a 12-gauge or thicker ground wire behind the ground fastener and securely tighten the ground fastener (E).
3. Connect the clamp end of the ground wire to a true earth ground.

NOTE: A ground wire and clamp (part number 238909) is available (purchase separately).

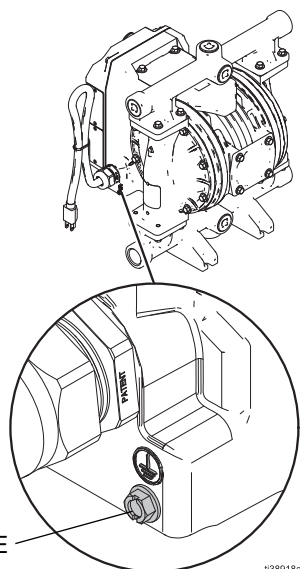

FIG. 10: Equipment Ground Fastener

Connect the Electrical Ground

For Models in Explosive Atmospheres or Hazardous (Classified) Locations: Ground through the ground wire of the power cable to a true earth ground. Connect the ground wire of the power cable to a true earth ground. See **Electrical Connections and Wiring**, starting on page 23.

For Models in Ordinary Locations: Ground through the provided power cord and plug. Connect the plug to a power outlet that is properly installed and grounded to a true earth ground.

Ground the Fluid Lines

Use only conductive fluid lines with a maximum of 500 ft (150 m) combined line length to ensure grounding continuity. Check electrical resistance of the fluid lines.

Ground the Fluid Supply Container

Follow local codes and regulations.

Ground the Pails for Solvents and Sanitizing Solution Used when Flushing

Follow local codes and regulations. Use only conductive metal pails, placed on a grounded surface. Do not place the pail on a non-conductive surface, such as paper or cardboard, which interrupts grounding continuity.

Verify Ground Continuity

Check the pump ground continuity after the initial installation. Set a regular schedule for checking ground continuity to maintain proper grounding. Do not exceed 1 ohm resistance from earth ground to the pump.

Before First Use

Tighten Fasteners

Before using the equipment for the first time, check and torque all fasteners. Follow **Torque Fasteners**, page 49.

After the first day of operation, re-torque the fasteners.

NOTICE

To avoid pump damage, do not over-torque the fasteners on the equipment.

Tighten Connections

Check and tighten all fluid connections before operating the equipment. Replace worn or damaged parts as needed.

NOTICE

Firmly tighten all connections to avoid leaks and damage to equipment parts.

Flush the Equipment

Before using the equipment for the first time, flush the equipment. Follow **Flush the Equipment**, page 35.

The equipment was tested with water. If water could contaminate the fluid being dispensed, flush the equipment with a compatible solvent before first use.





Electrical Connections and Wiring

Required Power and Plugs

				
To avoid injury from fire, explosion, or electric shock, all electrical wiring must be done by a qualified electrician and comply with all local codes and regulations.				

NOTE: For equipment provided with a cable and flying leads (no plug), install a main electrical disconnect per local codes and regulations.

NOTE: Use adapters as needed. Follow local codes and regulations.

Required Power and Plugs								
Location	Motor Configuration Code*	Model	Power Requirements				Cord/Cable Termination	Plug
			Input Voltage	Phase [‡]	Hertz	Current		
Ordinary Locations	FC1/FE1	i80 (QTD), i120 (QTE)	200–240 V	3	50/60 Hz	7.5 A	NEMA L15-20 Plug	
	FC2/FE2	i30 (QTC)	200–240 V	1	50/60 Hz	10 A	IEC 60320-C14 Plug [♦]	
		i80 (QTD), i120 (QTE)	200–240 V	1	50/60 Hz	15 A	IEC 60320-C20 Plug [♦]	
	FC5/FE5	i30 (QTC)	100–120 V	1	50/60 Hz	12 A	NEMA 5-15 Plug	
Hazardous (Classified) Locations	FC3/FE3	i80 (QTD), i120 (QTE)	200–240 V	3	50/60 Hz	7.5 A	Flying Leads, see FIG. 13	For permanent connection [■]
	FC6/FE6	i30 (QTC)	100–120 V	1	50/60 Hz	12 A	Flying Leads, see FIG. 12	
Explosive Atmospheres	FC4/FE4	i30 (QTC)	200–240 V	1	50/60 Hz	10 A	Flying Leads, see FIG. 12	
		i80 (QTD), i120 (QTE)	200–240 V	1	50/60 Hz	15 A		

* See **Configuration Matrix**, starting on page 9, for detailed descriptions.

[‡] Connect to a circuit with a main electrical disconnect. Install a branch circuit protective device in each ungrounded phase. Follow local codes and regulations.

[■] See **Wire Power Cables**, page 24.

[♦] Adapters are available (purchase separately). See **Adapters for Plugs and Cables**, page 25.

Wire Power Cables



For models in Explosive Atmospheres or Hazardous (Classified) Locations only.

To connect an Explosive Atmospheres or Hazardous (Classified) Locations model to a power source, complete one of the following:

- Hard wire the equipment to a power source.
- Supply a plug, socket, and interlocking device that meets the requirements of EN 60079-0 or UL 674.

NOTE: See **Required Power and Plugs**, page 23, for power requirements. Install a branch circuit protective device in each ungrounded phase.

A 15 ft (4.6 m) cable (either 3-conductor or 4-conductor) is provided with models for Explosive Atmospheres or Hazardous (Classified) Locations. Connect the cable directly to a panel with branch circuit protection and an electrical disconnect per local codes and regulations. If additional length of cable is required, connect additional cable through a junction box. Use the following table to select the minimum cable wire gauge based on length:

Length	Gauge	mm ²
50 ft (15.2 m)	12 AWG	3.3
100 ft (30.4 m)	10 AWG	5.3
200 ft (61 m)	8 AWG	13.3

NOTE: Ensure that the electrical disconnect (AA) is shut off and locked out before wiring. See FIG. 11.

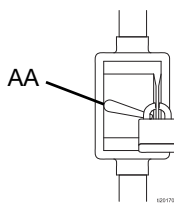

FIG. 11: Electrical Disconnect

Wire Single-Phase Models

For models in Explosive Atmospheres or Hazardous (Classified) Locations only. See FIG. 12.

1. **FC6/FE6 motors:** Connect the black wire to Line 1 (L1, black).
- FC4/FE4 motors:** Connect the brown wire to Line 1 (L1, brown).
2. **FC6/FE6 motors:** Connect the white wire to Neutral (L2/N, white).
- FC4/FE4 motors:** Connect the blue wire to Line 2 (L2/N, blue).
3. Connect the ground wire (green or green with yellow stripe) to a true earth ground.

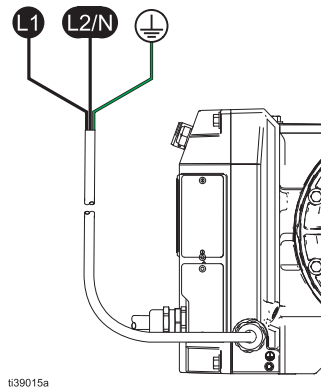

FIG. 12: Wiring for Single-Phase Models

Wire 3-Phase Models

For models in Explosive Atmospheres or Hazardous (Classified) Locations only. See FIG. 13.

1. Connect the black wire to Line 1 (black, L1).
2. Connect the white wire to Line 2 (white, L2).
3. Connect the red wire to Line 3 (red, L3).
4. Connect the ground wire (green or green with yellow stripe) to a true earth ground.

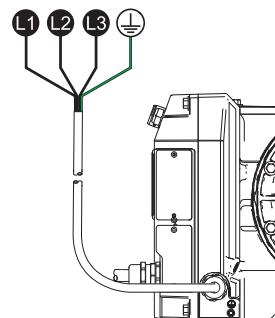

FIG. 13: Wiring for 3-Phase Models

Requirements for Cables and Conduits

For models in Explosive Atmospheres or Hazardous (Classified) Locations only.

<p>Do not modify or repair explosion proof joints. Modifying explosion proof joints may produce an explosion hazard.</p> <p>To avoid injury from fire, explosion, or electric shock, all electrical wiring must be done by a qualified electrician and comply with all local codes and regulations.</p>				

Requirements for Explosion Proof Equipment

Use appropriate conduits, connectors, and cable glands rated for Class I, Division I, Group D. Follow all national, state, and local electric codes and regulations.

Cable rating requirement: 158°F (70°C) minimum (all cables)

Cable gland rating requirement: 158°F (70°C) minimum (all glands)

Requirements for Flame Proof Equipment

Use appropriate conduits, connectors, and cable glands rated for Ex II 2 G. Follow all national, state, and local electric codes and regulations.

Cable rating requirement: 158°F (70°C) minimum (all cables)

Cable gland rating requirement: 158°F (70°C) minimum (all glands)

Adapters for Plugs and Cables

<p>To avoid injury from fire, explosion, or electric shock, all electrical wiring must be done by a qualified electrician and comply with all local codes and regulations.</p>				

Use adapters as needed. Follow local codes and regulations.

Adapters are available (purchase separately).

Plug Adapters			
Region	Part		Plug Adapter
	C14 Plugs	C20 Plugs	
Europe	242001	15G958	
Australia, China	242005	17A242	
Italy	---	15G959	
Italy	287121 Kit contains all three C14 Plugs	---	
Switzerland		15G961	
Denmark		---	

Plug Retainer Clips	
Plug	Part
C14 Plugs	195551
C20 Plugs	121249

I/O Port Flying Lead Cable Adapters (for models in Ordinary Locations only)	
Cable Length	Part
6.5 ft (2 m)	123846
50 ft (15 m)	17D160
98 ft (30 m)	17B590

I/O Pin Connection

				
<p>To avoid injury from fire, explosion, or electric shock, all electrical wiring must be done by a qualified electrician and comply with all local codes and regulations.</p>				

For models in Ordinary Locations only.

NOTE: All I/O connectors are capable of 30 VDC (volts of direct current) and are reverse-polarity protected.

For wiring, see **Equivalent Electrical Circuits for I/O Pin Connection**, page 27.

I/O Connector Pinout (for Models in Ordinary Locations only)		
Pin	Connector Type	Description
Pin 1 (Brown)	Digital Input	Used with Pin 3. Connect a switch to turn the pump on or off. Digital input has an internal 5 VDC pull-up for dry-contact or current-sinking circuits. Digital input is internally clamped for push-pull outputs. Release or drive the input high to stop the equipment from running. Pull the input low to re-enable the equipment.
Pin 2 (White)	Digital Output (Equipment Running)	Used with Pin 3. Tells an external device if the pump is or is not running. Digital output is current-sinking with a current capacity up to 100 mA. Digital output is internally clamped for driving large inductive loads. The output is automatically pulled low when the equipment is running and automatically released when the equipment is not running.
Pin 3 (Blue)	GND/Common	Earth ground, common connection.
Pin 4 (Black)	Analog Input, 4-20mA +	Analog inputs are 4–20 mA current-controlled. When the analog input is connected and driving current, the equipment disables the control knob (K) and uses the analog input to control the speed and pressure of the equipment. The control knob (K) can still be used to shut off the equipment by turning the knob to off (0). To re-enable the equipment at the speed and pressure commanded by the analog input, turn the control knob up (clockwise). To disable the analog input control and enable the control knob (K): <ol style="list-style-type: none"> 1. Disconnect power to the system. 2. Disconnect the analog input (Pin 4, Pin 5). 3. Connect the unit to a power source to turn on the equipment and enable the control knob (K) on the equipment.
Pin 5 (Gray)	Analog Input, 4-20mA -	

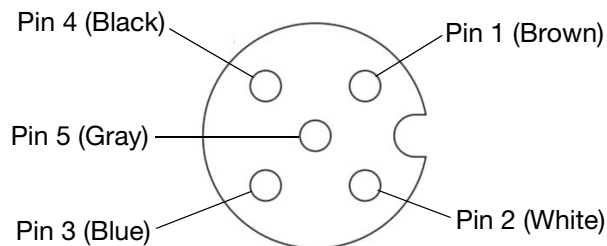

FIG. 14: M12, 5-pin Connector for Models in Ordinary Locations
Orientation: facing the connector on the pump body.

Equivalent Electrical Circuits for I/O Pin Connection

Equivalent Electrical Circuits for I/O Pin Connection (for Models in Ordinary Locations only)	
I/O Circuit	Equivalent Circuit
Digital Input	<p>5 VDC</p> <p>4.7 Kiloohms</p> <p>M12, Pin 1</p> <p>+</p> <p>Logic: Low (Run) < 2.0 V High (Stop) > 3.0 V</p> <p>- M12, Pin 3</p> <p>Maximum 30 VDC</p>
Compatible Drivers for Digital Input	
Switch or Relay	
Open Collector (NPN)	
Push-Pull Driver	<p>Maximum 30 VDC</p>

Equivalent Electrical Circuits for I/O Pin Connection (for Models in Ordinary Locations only)	
I/O Circuit	Equivalent Circuit
Digital Output	<p>M12, Pin 2</p> <p>+</p> <p>Maximum 30 VDC, Maximum 100 mA</p> <p>- M12, Pin 3</p> <p>Logic: Pump Running: Active Pump Stopped: Inactive</p>
Compatible Digital Output Circuit Drivers	
PLC With Internal Pull-up	<p>5-30 VDC</p> <p>PLC With Internal Pull-up</p> <p>M12 Pin 2</p> <p>+</p> <p>100 mA Max</p> <p>M12 Pin 3</p> <p>-</p>
PLC without Internal Pull-up	<p>5-30 VDC</p> <p>PLC</p> <p>PLC without Internal Pull-up</p> <p>M12 Pin 2</p> <p>+</p> <p>100 mA Max</p> <p>M12 Pin 3</p> <p>-</p>

Equivalent Electrical Circuits for I/O Pin Connection (for Models in Ordinary Locations only)	
I/O Circuit	Equivalent Circuit
Digital Output	<p>Relay or Solenoid</p>
	<p>LED</p>
	<p>Lamp</p>
Analog Input	<p>Maximum 30 VDC</p>

Operation

Pressure Relief Procedure

 Follow the Pressure Relief Procedure whenever you see this symbol.



This equipment stays pressurized until pressure is manually relieved. To help prevent serious injury from pressurized fluid, such as splashing fluid and moving parts, follow the **Pressure Relief Procedure** when you stop operating and before cleaning, checking, or servicing the equipment.

1. Turn the fluid output control knob (K) to off (0) and disconnect power to the system.
2. Close the fluid shutoff valve (H).
3. Open the fluid drain valve (G) to relieve fluid pressure. Prepare a container to catch the drainage.
4. Leave the fluid drain valve (G) open until the system is ready to be pressurized.

Before Each Use

Tighten Fasteners

Check and tighten all fasteners before operating the equipment. Re-torque as needed. Follow **Torque Fasteners**, page 49.

NOTICE

To avoid pump damage, do not over-torque the fasteners on the equipment.

Tighten Connections

Check and tighten all fluid connections before operating the equipment. Replace worn or damaged parts as needed.

NOTICE

Firmly tighten all connections to avoid leaks and damage to equipment parts.

Flush the Equipment

Flush the equipment before each use. Determine whether to disassemble and clean individual parts or simply flush the equipment with a compatible solvent.

To simply flush the equipment with a compatible solvent, follow **Start the Equipment**, page 29, and **Flush the Equipment**, page 35.

To disassemble and clean individual parts, see the applicable repair procedure. See **Repair**, starting on page 40.

Start the Equipment



To prevent serious injury from splashing fluid, ensure the control knob (K) is set to off (0) before connecting the equipment to a power source.

Prepare the Equipment for Startup

1. Turn the control knob (K) to off (0).
2. Confirm that the equipment is properly grounded. See **Grounding**, page 21.
3. Check and tighten all fasteners and connections before operating the equipment. Replace worn or damaged parts as needed.
4. Insert the suction end of the fluid supply line (F) into the fluid to be dispensed.
5. Insert the outlet end of the fluid outlet line (J) into the end container.
6. Close the fluid drain valve (G).
7. Ensure all fluid shutoff valves (H) are open.
8. If the fluid outlet line (J) has a dispensing device, hold the dispensing valve open into the end container.

Start and Adjust the Equipment

1. Follow **Prepare the Equipment for Startup**, page 29.
2. Connect the equipment to a power source. See **Electrical Connections and Wiring**, starting on page 23.
NOTE: The pump will automatically start cycling if the pump is connected to power and the control knob (K) is not set to off (0).
3. After the alert beep sounds, allow the equipment to complete the startup sequence. See **LED Indicator Overview**, page 32.

The LED indicator light illuminates solid yellow while calibrating. The pump cycles slowly while adjusting and operates normally after fully calibrating.

The system stays calibrated as long as power to the system is connected. If power to the system is disconnected, the system will automatically recalibrate after power is restored.

4. Slowly increase the control knob (K) until the equipment is operating at the set output level.
5. If flushing, run the equipment long enough to thoroughly clean the equipment and lines.

Tips to Reduce Cavitation

NOTICE

Frequent or excessive cavitation can cause serious damage, including pitting and early wear of wetted parts, and may result in reduced efficiency of the equipment. Cavitation damage and reduced efficiency both result in increased operating costs.

Cavitation is the formation and collapse of air pockets in the fluid. Cavitation depends on the vapor pressure of the fluid, the system suction pressure, and the velocity pressure. Viscous fluids are more difficult to pump and more prone to cavitation than non-viscous fluids.

To improve equipment efficiency and reduce the cavitation:

1. **Reduce vapor pressure:** Decrease the temperature of the fluid.
2. **Increase suction pressure:**
 - a. Position the equipment lower than the fluid level in the supply.

- b. Reduce the number of fittings on the suction lines to reduce friction length.
- c. Increase the diameter of the suction lines.
- d. Reduce the fluid inlet pressure. An inlet pressure supply of 3–5 psi (21–35 kPa, 0.2–0.3 bar) is adequate for most materials.

NOTICE

To avoid pump damage and inefficient operation, do not use a fluid inlet pressure greater than 25 percent of the outlet working pressure.

- e. Increase the Net Positive Suction Head (NPSH). See **Performance Charts**, page 53.

3. **Reduce liquid velocity:** Slow the equipment cyclic rate.

Consider all the previously listed factors in system design. To maintain efficiency, operate the equipment at the lowest speed and pressure setting needed for the required flow.

Contact your local distributor for site-specific suggestions to improve equipment performance and reduce operating costs.

Disable Auto-Prime

The auto-prime sensor detects fluid while the equipment is operating. The equipment will run as long as fluid is detected. If fluid is not detected, the auto-prime sequence will restart.

Auto-prime is enabled by default. To disable auto-prime:

1. Follow **Remove the Control Cover**, in the control cover repair procedures in the motor manual. See **Related Manuals** on page 3.
2. Locate the auto-prime switch (AP). See FIG. 15 or **Electrical Schematics** in the motor manual.
3. Push the auto-prime switch (AP) to the left (off) position.
4. Follow **Install the Control Cover** in the control cover repair procedures in the motor manual.

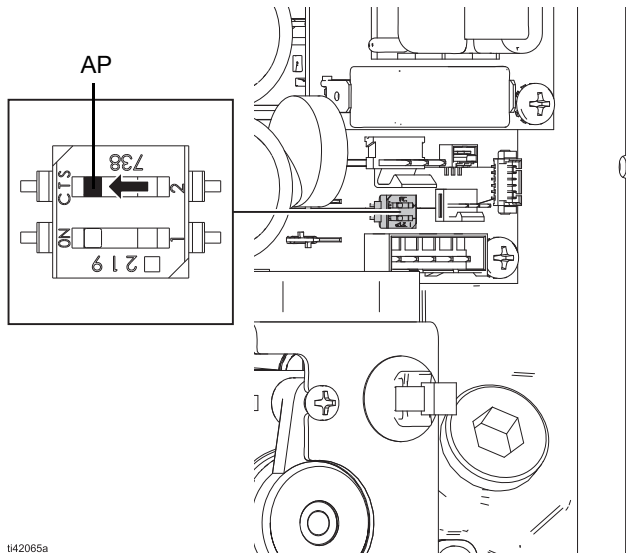

142065a

FIG. 15: Disable Auto-Prime

Shut Down the Equipment



1. Follow **Pressure Relief Procedure**, page 29.
2. Follow **Flush the Equipment**, page 35.

LED Indicator

LED Indicator Overview

LED Indicator	Equipment Status	Notes
Red, solid	Powered on, speed set at 0 (zero), system not operating.	Be aware that the equipment is energized. To initiate equipment operation, follow Start the Equipment , page 29.
Red, flashing	Motor fault, motor error.	See LED Indicator Event Errors , page 33.
Yellow, solid	Calibrating. Performing startup sequence.	No action. Allow equipment to finish startup sequence. Open the fluid drain valve (G) or fluid shutoff valve (H) to allow the equipment to cycle until the startup sequence is finished.
Yellow, flashing	Leak sensor alert.	See “Leak sensor alert” LED Indicator Event Errors , page 34.
Green, solid	Startup sequence complete.	To initiate equipment operation, follow Start the Equipment , page 29.
	Normal operation.	No action.
Green, flashing	Normal operation, stalled against pressure.	Be aware that the equipment is energized. Special-case action. See LED Indicator Event Errors , page 33.
No light (off)	System not powered.	See LED Indicator Event Errors , page 33.

LED Indicator Event Errors

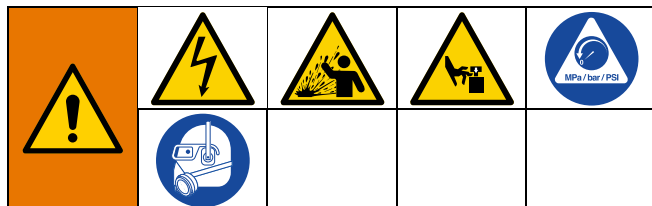

If an event error occurs, the LED Indicator will blink a set number of times corresponding to the event code that needs acknowledged.

Follow the **Pressure Relief Procedure**, page 29, before checking or repairing the equipment.

Check all possible problems and causes before disassembling equipment.

LED Indicator Event Errors			
LED Indicator	Problem	Cause	Solution
Red, flashing, one flash	Motor or controller overheating.	Hot operating environment or hot operating conditions.	Turn the control knob (K) to the off (0) position. Keep the system connected to power and allow the equipment to cool before returning to operation.
			Inspect the fan. Repair or replace as needed. See your related motor manual. See Related Manuals , page 3.
Red, flashing, two flashes	Motor current error.	Special-case cause.	Turn the control knob down, then back up. If the problem persists, contact Technical Support.
Red, flashing, three flashes	Voltage error or pump priming failure.	Input voltage is too high, too low, or too noisy, or an operational parameter of the motor was exceeded while priming.	Check line power voltage.
			Check control board connections. See your related motor manual. See Related Manuals , page 3.
			If the pump has flapper check valves, reduce the output pressure of the pump via a valve or the control knob (K). Pumps with flapper check valves are unable to prime fluid against pressure. If the problem persists or if the pump has ball check valves, examine all check valves to ensure they are checking and opening correctly.
Red, Flashing, four flashes	Motor sensor error.	Motor sensor disconnected.	Ensure the motor sensor cable is properly installed. See your related motor manual. See Related Manuals , page 3.
		Motor sensor not functioning.	Replace the motor sensor. See your related manuals. See your related motor manual. See Related Manuals , page 3.

LED Indicator Event Errors			
LED Indicator	Problem	Cause	Solution
Red, flashing, five flashes	Special-case problem.	Special-case cause.	Power cycle the unit. If the error persists, contact Technical Support.
Red, flashing, six flashes	Motor lead connection error.	One or more motor leads are connected incorrectly.	Check that all motor connections to the control board are correct.
Dim red, solid	Voltage detection error.	Power disconnected.	Check power connection.
		System powering down.	Allow equipment to finish shutdown.
Yellow, flashing, continuous flash	Leak sensor alert.*	Leak detected in the equipment.	Check the diaphragm for rupture or incorrect installation. Repair or replace. Ensure that the diaphragm is torqued to specification.
		The leak sensor disconnected.	Ensure the leak sensor is properly installed. See your related leak sensor manual. See Related Manuals , page 3.
Green, flashing, continuous flash	Equipment stalled against pressure.	A valve downstream in the fluid line is closed or clogged.	Open the valve.
			Follow the Pressure Relief Procedure , page 29, and clear the valve.
		Special-case cause.	Be aware that the equipment is energized. Special-case action. See your related motor manual. See Related Manuals , page 3.
No light (off)	Voltage detection error.	System not powered.	Contact Technical Support.
			Check power connection.
			Check the branch circuit for proper voltage.
			Replace the control board. See your related motor manual. See Related Manuals , page 3.

* A leak sensor is not provided with the equipment. Accessory kits are available (purchase separately). See your related motor manual. See **Related Manuals**, page 3.

Maintenance

Establish a Preventive Maintenance Schedule

NOTICE

Regularly maintain the equipment to avoid pump damage due to spills, leaks, or diaphragm failure.

Establish a preventive maintenance schedule based on the equipment service history.

Inspect the Equipment

Regularly inspect the equipment for worn or damaged parts. Replace as needed.

Tighten Fasteners

Regularly check and torque all fasteners. Follow **Torque Fasteners**, page 49.

NOTICE

To avoid pump damage, do not over-torque the fasteners on the equipment.

Tighten Connections

Check and tighten all fluid connections before operating the equipment. Replace worn or damaged parts as needed.

NOTICE

Firmly tighten all connections to avoid leaks and damage to equipment parts.

Lubricate the Equipment

The equipment is lubricated at the factory. Re-lubricate the equipment when replacing diaphragms.

Lubricate the motor rotor when replacing diaphragms. See your related motor manual. See **Related Manuals**, page 3.

NOTICE

Do not over-lubricate the equipment. Lubricant exhaust could contaminate your fluid supply or other equipment. Excessive lubrication can also cause the equipment to malfunction.

Flush the Equipment

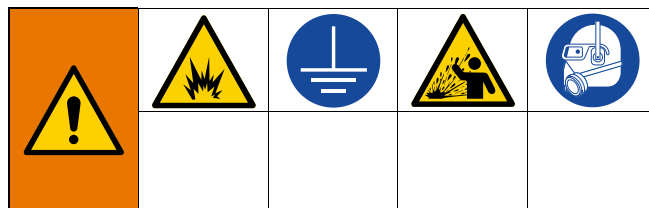

To avoid fire and explosion, always ground the equipment and waste container. To avoid static sparking and injury from splashing, always flush at the lowest possible pressure.

- Flush before fluid can dry or freeze in the equipment, at the end of the day, before storing, and before repairing equipment.
 - Flush at the lowest pressure possible. Check connections for leaks and tighten as needed.
 - Flush with a solvent that is compatible with the fluid being dispensed and the equipment wetted parts. Use a sanitary solution for hygienic applications.
 - Flushing schedule varies based on particular uses.
 - Always cycle the equipment during the entire flushing process.
1. Follow **Pressure Relief Procedure**, page 29.
 2. Insert the suction end of the fluid supply line (F) into a compatible solvent.
 3. Close the fluid drain valve (G).
 4. Ensure the control knob (K) is turned to off (0).
 5. If the fluid outlet line (J) has a dispensing device, place a metal part of the dispensing device to a grounded metal container and hold the dispensing valve open.
 6. Ensure all fluid shutoff valves (H) are open.
 7. Connect the equipment to a power source. See **Electrical Connections and Wiring**, starting on page 23.
 8. Slowly increase the control knob (K) until the equipment is operating at the set output level.
 9. Run the equipment for enough time to thoroughly clean the equipment and lines.
 10. Turn the control knob (K) to off (0).
 11. Follow **Pressure Relief Procedure**, page 29.

Store the Equipment



Always relieve the pressure and flush the equipment before storing the equipment for any length of time.

1. Follow **Pressure Relief Procedure**, page 29.
2. Follow **Flush the Equipment**, page 35.

NOTICE

Store the equipment at 32°F (0°C) or higher. Exposure to extreme low temperatures may result in damage to plastic parts.

Clean the Wetted Section



Routinely clean the wetted section. Determine whether or not to disassemble equipment for cleaning.

- To clean the equipment without disassembling parts, follow **Clean In-Place (CIP)**, page 36.
- To clean the equipment by disassembling parts, follow **Clean Out-of-Place (COP)**, page 36.

Clean in accordance with applicable codes and local regulations for your compatible solvent.

Clean In-Place (CIP)

NOTICE

To avoid equipment damage, only use cleaning fluids that are compatible with materials of the wetted section. To avoid damage to stainless steel parts, do not use chlorinated cleaning fluids. Do not exceed the maximum fluid temperature for the materials of the wetted section. See **Fluid Temperature Range**, page 72.

1. Follow **Pressure Relief Procedure**, page 29.
2. Flush the equipment with a compatible solvent. Follow **Flush the Equipment**, page 35.
3. Circulate the compatible solvent through the equipment. Slowly cycle the equipment as the compatible solvent is circulated.

NOTE: Thoroughly circulate the compatible solvent through the equipment and the system prior to use.

NOTICE

To avoid equipment damage, do not exceed a fluid inlet pressure of 15 psi (103 kPa, 1 bar) when cycling the equipment.

4. Follow **Pressure Relief Procedure**, page 29.

Clean Out-of-Place (COP)

1. Follow **Pressure Relief Procedure**, page 29.
2. Flush the equipment with a compatible solvent. Follow **Flush the Equipment**, page 35.
3. Disassemble parts as needed. See **Repair**, starting on page 40.
4. Inspect parts for wear or damage. Replace as needed.
5. Using a brush or other COP methods, wash all wetted parts with a compatible solvent at the recommended temperature and concentration of the manufacturer.
6. Rinse the parts again with water and allow parts to completely dry.
7. Inspect the parts and re-clean any soiled parts.
8. Reassemble the equipment as needed. See **Repair**, starting on page 40.
9. Flush the equipment with a compatible solvent. Follow **Flush the Equipment**, page 35.
10. Circulate the compatible solvent through the equipment. Slowly cycle the equipment as the compatible solvent is circulated.

NOTE: Thoroughly circulate the compatible solvent through the equipment and the system prior to use.

NOTICE

To avoid equipment damage, do not exceed a fluid inlet pressure of 15 psi (103 kPa, 1 bar) when cycling the equipment.

11. Follow **Pressure Relief Procedure**, page 29.

Troubleshooting



Follow the **Pressure Relief Procedure**, page 29, before checking or repairing the equipment.



Check all possible problems and causes before disassembling equipment.

Problem	Cause	Solution
Equipment emits beeping alert sound, LED light yellow	Pump starting automatic startup sequence. Pump is connected to a power source and the control knob (K) is not set to the off (0) position.	Turn the control knob (K) to the off (0) position or disconnect power to the system. If prepared to operate, allow the pump to complete the automatic startup sequence.
	LED light flashing	Equipment error; special-case cause. See LED Indicator Event Errors , page 33.
Equipment cycles, but does not prime or pump (It is normal operation for auto-prime to run and then stop once the pump is primed).	Equipment running too fast, causing cavitation before prime.	Slow down the motor speed.
	Fluid not detected by the auto-prime sensor.	Ensure the suction end of the fluid supply line (F) is inserted into the fluid to be dispensed. Allow the auto-prime sequence to run for 30 seconds.
	Check is worn or wedged in the seat or manifold.	Replace check and seat.
	Worn seat.	Replace check and seat.
	Restricted outlet or inlet port.	Remove restriction.
	Loose inlet fittings or manifolds.	Tighten.
Equipment does not hold fluid pressure at stall	Damaged manifold seats.	Replace.
	Worn check, seats, or seals.	Replace.
	Loose manifold connections or fluid connections.	Tighten.
Equipment leaking fluid externally from joints [‡]	Loose diaphragm shaft fastener.	Tighten.
	Loose manifold connections or fluid cover connections.	Tighten.
	Worn manifold seats or seals.	Replace.

Problem	Cause	Solution
Equipment leaks fluid externally from the joint between the center manifold and manifold. (Flapper pumps only)	Worn or damaged gaskets (53).	Replace gaskets (53), see Reassemble the Check Valves , page 42.
	Gasket (53) not installed properly. Manifold (5 or 4) not fully installed at joint to the center manifold (54).	Thoroughly grease the gasket (53) and the inner diameter of the manifold (5 or 4) before assembling manifold. Ensure the gasket (53) is fully installed on the outer diameter of the center manifold (54). Ensure the manifold (5 or 4) is properly aligned to the equipment. Ensure the center manifold (54) and manifold (5 or 4) are fully connected at the joint. See Reassemble the Check Valves , page 42.
Equipment stalled, will not cycle	Fluid line clogged or valves closed.	Inspect; clear. Open valves downstream of the equipment.
	Motor or controller wired improperly.	Wire per instructions in your related motor manual. See Related Manuals , page 3.
	Leak sensor tripped.	Check diaphragm for rupture or incorrect installation. Repair or replace.
Reduced performance	Fluid line clogged.	Inspect; clear.
	Checks are sticky or leaking.	Clean or replace.
	Diaphragm (or backup diaphragm, if applicable) ruptured.	Replace.
Air bubbles in fluid	Fluid line is loose.	Tighten.
	Diaphragm (or backup diaphragm, if applicable) ruptured.	Replace.
	Loose manifolds.	Tighten manifold fasteners or clamps.
	Damaged seats or seals.	Replace seats or seals.
	Loose diaphragm shaft fastener.	Tighten.
Fluid leaking from lower ports on the equipment or fluid on the floor.	Loose diaphragm shaft fastener.	Tighten.
	Diaphragm rupture. Leak in the equipment.	Replace.







Problem	Cause	Solution
Equipment suddenly stops operating or shuts down.	Ground fault circuit interrupter (GFCI) tripped.	Remove controller from the GFCI circuit.
	Poor supply power.	Check connections. Determine and fix the source of the problem with the supply power.
	Exceeded operational parameters.	See LED Indicator Event Errors , page 33, for event codes.
	Leak sensor* alert. Leak detected in the equipment.	Check the diaphragm for rupture or incorrect installation. Repair or replace.
	The leak sensor* disconnected.	Ensure the leak sensor is properly installed. See your related leak sensor manual.

* A leak sensor is not provided with the equipment. Accessory kits are available (purchase separately). See **Related Manuals**, page 3.

				
<p>‡ Do not modify or repair explosion proof joints. Modifying explosion proof joints will invalidate the Hazardous Location Certification of the equipment and may produce an explosion hazard.</p>				

Repair

NOTE: Repair kits are available (purchase separately).



				
				

This equipment stays pressurized until pressure is manually relieved. To help prevent serious injury from pressurized fluid, such as splashing fluid and moving parts, follow **Pressure Relief Procedure** when you stop operating and before cleaning, checking, or servicing the equipment.



To avoid severe burns, do not touch hot fluid or hot equipment.

Follow **Prepare Equipment for Repair**, page 40, before performing any service or repair to the equipment.

Prepare Equipment for Repair

				
---	---	---	--	--

To avoid injury from fire, explosion, or electric shock, all electrical wiring must be done by a qualified electrician and comply with all local codes and regulations.

				
---	---	--	--	--

Models in Explosive Atmospheres or Hazardous (Classified) Locations: To avoid injury from fire and explosion, move the equipment to a non-explosive or non-hazardous location before performing any service or repair to the equipment.

Always complete the following procedure before performing any service or repair to the equipment.

1. Follow **Pressure Relief Procedure**, page 29.
2. Follow **Flush the Equipment**, page 35.
3. Verify that the equipment is turned off and power to the system is disconnected before performing any service or repair procedure.

4. Disconnect all fluid lines.
5. Optional: Mount the back of the pump (opposite side from the motor) to the maintenance bracket stand (purchase separately). See related parts manual. See **Related Manuals**, Page 3. This positions the pump facing up, enabling easy working access to the pump and motor. The stand can be mounted to a workbench through the mounting holes on the feet. See FIG. 16.
 - a. Loosen the four bolts that hold the logo plate (if present) to the pump.
 - b. Slide the bracket stand behind the bolts.
 - c. Tighten the bolts.
 - d. After repairing the pump, remove the pump from the bracket stand and return it to service.

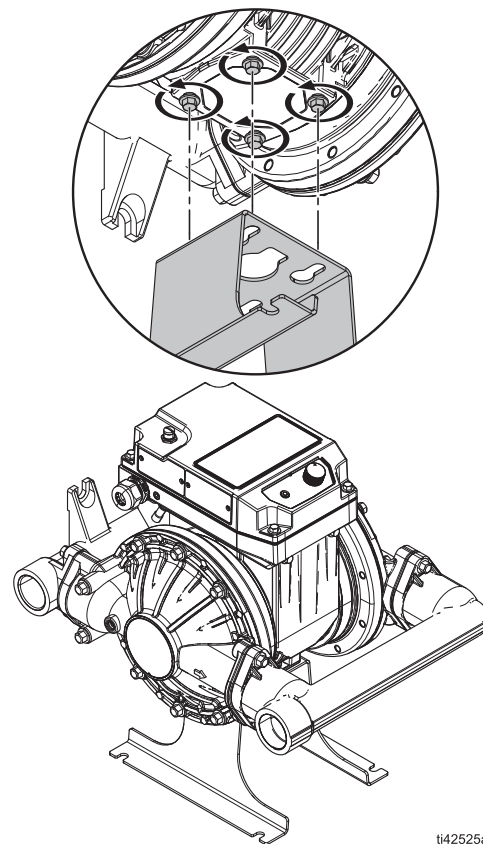

ti42525a

FIG. 16. Maintenance bracket stand

Repair the Check Valves (Ball Pumps)

Required Tools:

- 10 mm socket wrench (for all i30 (QTC) models, i80 (QTD) plastic models, and i120 (QTE) plastic models)
- 13 mm socket wrench (for i80 (QTD) metal models and i120 (QTE) metal models)

See FIG. 17.

Disassemble the Check Valves



1. Follow **Prepare Equipment for Repair**, page 40.
2. Drain the equipment.

NOTE: After draining, rotate the equipment to positions which will aid disassembly.

3. On the outlet manifold (4), remove all fasteners (6).
4. Remove the outlet manifold (4), seals (10, if applicable), guides (9b, if applicable), checks (9), and seats (8).

NOTE: Use care while removing manifolds to avoid damage to check valve components.

5. On the inlet manifold (5), remove all fasteners (6, 6b, if applicable).
6. Remove the inlet manifold (5), seals (10, if applicable), guides (9b, if applicable), checks (9), and seats (8).

NOTE: Use care while removing manifolds to avoid damage to check valve components.

7. Clean and inspect parts for wear or damage. Replace as needed.

Reassemble the Check Valves

1. Align and place seats (8), checks (9), guides (9b, if applicable), seals (10, if applicable), and manifolds (4, 5), exactly as shown for your equipment model. See your related parts manual. See **Related Manuals**, page 3.
2. Use the fasteners (6, 6b, if applicable) to loosely attach the manifolds (4, 5) to the fluid covers (3). After all components are properly aligned, torque the fasteners (6, 6b, if applicable) on the manifolds (4, 5). See **Torque Fasteners**, page 49.

 See **Torque Fasteners**, page 49.

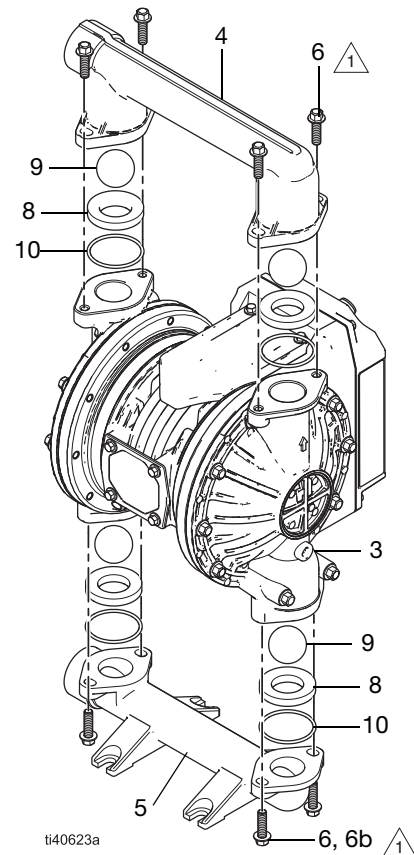

FIG. 17: Check Valves

Repair the Check Valves (Flapper Pumps)

Tools Required:

- Torque wrench
- 4 mm hex key
- 15 mm socket wrench

See parts manual in **Related Manuals**, page 3, for available repair kits. Service the check valves as follows.

See FIG. 18.

Disassemble the Check Valves



1. Follow **Prepare Equipment for Repair**, page 40.
2. Remove clevis and cotter pins (35, 36) from manifolds (5, 4).
3. Remove bolts (6).
4. Remove manifolds from fluid covers (3).

NOTE: Use care while removing manifolds to avoid damage to check valve components.

5. Remove all check valve components and gaskets (53).

NOTE: Pay attention to the orientation of the check valve components for reassembly.

6. Clean and inspect all parts for wear or damage. Replace as needed.

NOTE: To ensure proper seating, always replace all gaskets, seats, and check valve components when performing check valve repairs.

Reassemble the Check Valves

1. Install all check valve components in the correct orientation. See FIG. 18.

NOTE: Ensure that the check valves and seating areas are clean.

NOTE: Install the flapper valves with the solid rubber side facing toward the seat.

Install gaskets (53) onto the outer diameter of the center manifolds (54).

NOTE: Before reassembling manifolds, grease both surfaces of the gasket (53) and the mating inner diameter of the manifolds (5, 4).

NOTE: Always replace the manifold gaskets (53) when repairing the equipment.

2. Align manifolds (5, 4) with the fluid covers (3) and center manifold (54).
3. Simultaneously connect the manifolds (5, 4) to the joints at the fluid cover (3) and center manifold (54).

NOTE: For proper installation, ensure that the manifold joints are connected at the same time.

4. Insert screws (6) and torque. See **Torque Sequence**, page 49.

Repair the Standard Diaphragms

Required Tools:

- 10 mm socket wrench (for all i30 (QTC) models, i80 (QTD) plastic models, and i120 (QTE) plastic models)
- 13 mm socket wrench (for i80 (QTD) metal models and i120 (QTE) metal models)
- Torque wrench
- 25 mm open-end wrench
- Lubriplate® Synxtreme HD-2 grease (part number 18F990) or equivalent NLGI Grade 2 synthetic grease with calcium sulfonate base

See FIG. 19–FIG. 21.

NOTE: Lubricate the motor rotor when replacing diaphragms. See your related motor manual. See **Related Manuals**, page 3.

Disassemble the Standard Diaphragms

				
To avoid severe burns, do not touch hot fluid or hot equipment.				

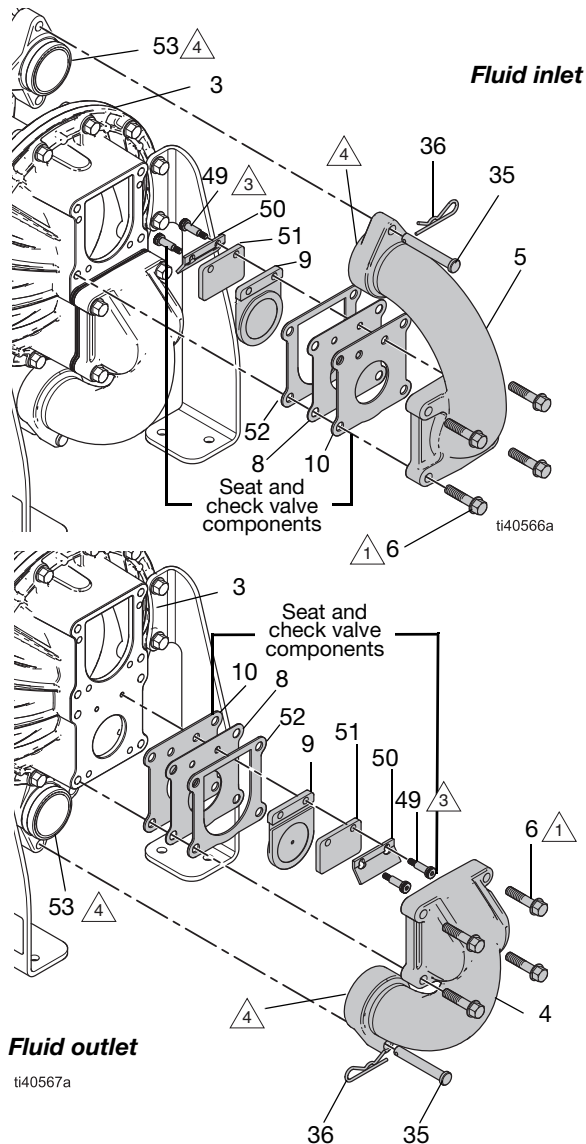

- 1 Apply medium-strength (blue) thread locker to the threads. Torque to 190–220 in-lb (21.5–24.9 N•m). See **Torque Sequence**, page 49.
- 3 Apply medium-strength (blue) thread locker to the threads. Torque to 20–25 in-lb (2.26–2.82 N•m).
- 4 Grease.

FIG. 18: Check Valve Section

1. Follow **Prepare Equipment for Repair**, page 40.
2. Follow **Disassemble the Check Valves**, page 41.
3. Remove all fasteners (7, 7b, if applicable) from the fluid covers (3). Remove the fluid covers (3).
4. Use an applicable wrench to firmly hold one diaphragm fastener (15) in place. At the same time, use an applicable wrench to loosen the fastener (15) on the opposite side.
5. Remove the fastener (15), seal (16, if applicable), fluid plate (11), diaphragm (13), and diaphragm backer (14) from the shaft (1a) on the side of the pump with the loosened fastener (15).
6. Loosen the remaining diaphragm fastener (15).

If the first loosened diaphragm fastener (15) is on the side of the shaft (1a) with the wrench flat:

- a. Use an applicable wrench to firmly hold the flat of the shaft (1a) in place. At the same time, use an applicable wrench to loosen the remaining diaphragm fastener (15). See FIG. 21.

If the first loosened diaphragm fastener (15) is opposite the wrench flat on the shaft (1a):

- a. Follow the procedure to lubricate the rotor in your related motor manual to access the flat of the shaft (1a). See **Related Manuals**, page 3.
 - b. After the flat of the shaft (1a) is accessible, use an applicable wrench to firmly hold the flat of the shaft (1a) in place. At the same time, use an applicable wrench to loosen the remaining diaphragm fastener (15). See FIG. 21.
7. Remove the remaining fastener (15), seal (16, if applicable), fluid plate (11), diaphragm (13), and diaphragm backer (14), and air-side plate (21) from the shaft (1a).

NOTE: Do not remove the diaphragm shaft (1a) from the motor (1).

NOTICE

To avoid damage to the rotor or equipment, do not remove the shaft (1a) from the motor (1). Removing the shaft will cause the rotor balls to dislodge from the rotor and the rotor will not function properly.

8. Clean and inspect parts for wear or damage. Replace parts as needed.
9. Lubricate the rotor. See your related motor manual. See **Related Manuals**, page 3.

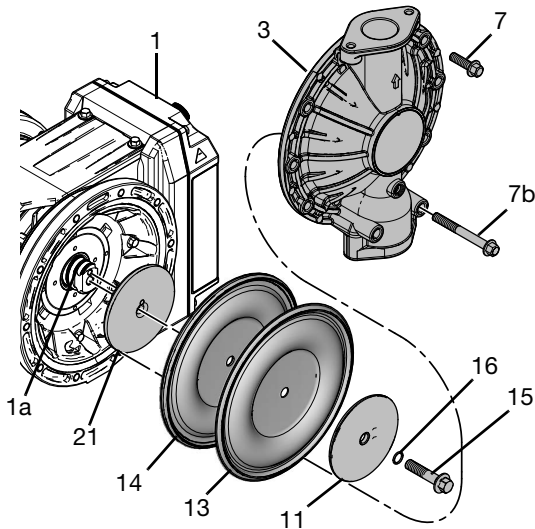

ti40626a

FIG. 19: Standard Diaphragms

Reassemble the Standard Diaphragms

NOTICE

After reassembly, allow the thread locker to cure for 12 hours, or per instructions of the manufacturer, prior to operating the equipment. The equipment will be damaged if the diaphragm shaft fastener loosens.

1. Assemble the air-side plate (21), diaphragm backers (14), diaphragms (13), fluid side plates (11), and seals (16, if applicable) with the fasteners (15) exactly as shown for your equipment model. See your related parts manual. See **Related Manuals**, page 3.

NOTE: Face the rounded side of the fluid side plate (11) toward the diaphragm (13).

NOTE: Regardless of any markings on the diaphragm backer (14), always assemble the diaphragm backer (14) so that the outer bead cups around (not away from) the outer bead of the diaphragm (13).

NOTE: Apply thread locker to the fastener (15) for all diaphragm assemblies.

- 1 Apply a medium-strength thread locker to the shaft side of the fastener to attach the diaphragm to the shaft.
- 2 Rounded side faces toward the diaphragm (13).

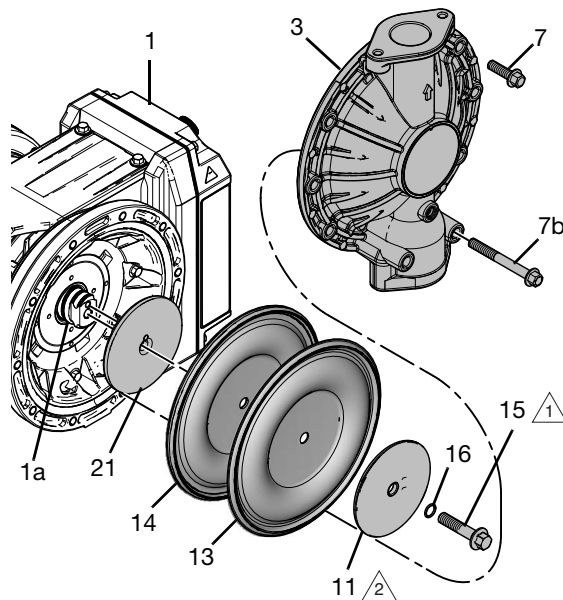

ti40626a

FIG. 20: Reassemble Standard Diaphragms

2. Install the assembled diaphragm assemblies into the shaft (1a) and hand-tighten the fasteners (15).
3. Use an applicable wrench to firmly hold one fastener (15) in place. At the same time, use an applicable wrench to torque the opposite fastener (15) to 50 ft-lb (68 N•m). See FIG. 21.

 Torque to 50 ft-lb (68 N•m).

 See **Torque Fasteners**, page 49.

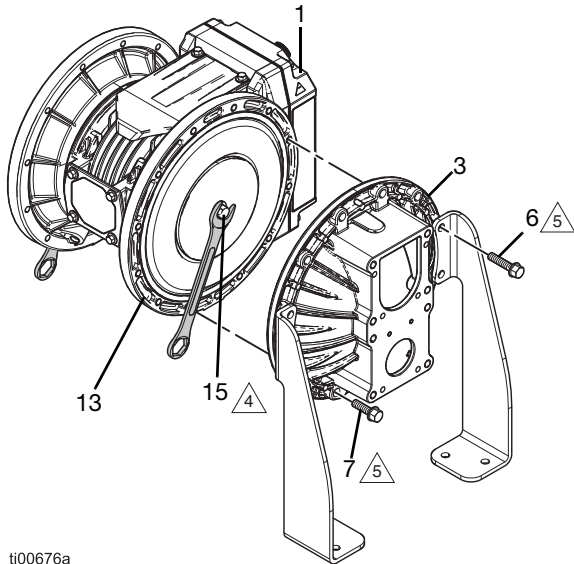

ti00676a

FIG. 21: Tighten Standard Diaphragms

4. Rotate the shaft of the motor to center it in the motor, so that neither diaphragm is extended away from the housing, which could inhibit installing the fluid covers.

NOTE: If it is not possible for both diaphragms to be in contact with the housing, choose one diaphragm to position first. Once the first fluid cover is fastened, slowly drive the motor so that the other diaphragm is in contact with the housing. Then fasten the second fluid cover.

5. Align the fluid covers (3) to the motor (1).

NOTE: On flapper covers, the circular outlet hole must be at the base of the equipment. See FIG. 21.

6. Install fasteners (7, 7b, if applicable) to hold the fluid covers (3) in place.

NOTE: To ensure proper spacing and alignment of the manifolds (4, 5), install fasteners (7, 7b, if applicable) loose enough to allow for fluid cover movement before securing the fluid covers (3) in place.

7. Torque all fasteners (6, 7, 7b, as applicable). Follow **Torque Fasteners**, page 49.
8. Reassemble the check valves and manifolds as explained in **Reassemble the Check Valves**, page 41.

Repair the Overmolded Diaphragms

Required Tools:

- 10 mm socket wrench (for all i30 (QTC) models, i80 (QTD) plastic models, and i120 (QTE) plastic models)
- 13 mm socket wrench (for i80 (QTD) metal models and i120 (QTE) metal models)
- Torque wrench
- 25 mm open-end wrench
- Lubriplate® Synxtreme HD-2 grease (part number 18F990) (or equivalent NLGI Grade 2 synthetic grease with calcium sulfonate base)

See FIG. 22–FIG. 24.

NOTE: Lubricate the motor rotor when replacing diaphragms. See your related motor manual. See **Related Manuals**, page 3.

Disassemble the Overmolded Diaphragms



To avoid severe burns, do not touch hot fluid or hot equipment.

1. Follow **Prepare Equipment for Repair**, page 40.
2. Follow **Disassemble the Check Valves**, page 41.
3. Remove all fasteners (7, 7b, if applicable) from the fluid covers (3). Remove the fluid covers (3).
4. Firmly grip the outer edge of a diaphragm (13) to hold in place. At the same time, securely grip the outer edge of the opposite diaphragm (13) and rotate counterclockwise to loosen. Remove the diaphragm (13).

NOTE: If needed, leave one fluid cover fastened. With one diaphragm exposed, use both hands to loosen the exposed diaphragm.

NOTE: Do not remove the diaphragm shaft (1a) from the motor (1).

NOTICE

To avoid damage to the rotor or equipment, do not remove the shaft (1a) from the motor (1). Removing the shaft will cause the rotor balls to dislodge from the rotor and the rotor will not function properly.

5. Remove the remaining diaphragm (13).

If the first loosened diaphragm (13) is on the side of the shaft (1a) with the wrench flat:

- a. Use an applicable wrench to firmly hold the flat of the shaft (1a) in place. At the same time, securely grip the outer edge of the opposite diaphragm (13) and rotate counterclockwise to loosen.

If the first loosened diaphragm (13) is opposite the wrench flat on the shaft (1a):

- a. Follow the procedure to lubricate the rotor in your related motor manual to access the flat of the shaft (1a). See **Related Manuals**, page 3.
- b. After the flat of the shaft (1a) is accessible, use an applicable wrench to firmly hold the flat of the shaft (1a) in place. At the same time, securely grip the outer edge of the opposite diaphragm (13) and rotate counterclockwise to loosen.

6. Clean and inspect parts for wear or damage. Replace parts as needed.
7. Lubricate the rotor. See your related motor manual. See **Related Manuals**, page 3.

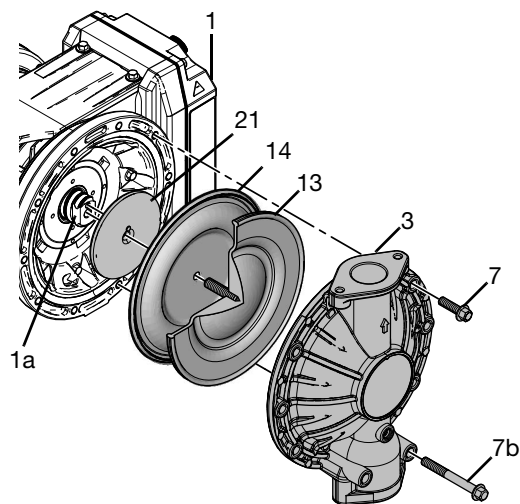

ti40627a

FIG. 22: Overmolded Diaphragms

Reassemble the Overmolded Diaphragms

NOTICE

After reassembly, allow the thread locker to cure for 12 hours, or per instructions of the manufacturer, prior to operating the equipment. The equipment will be damaged if the diaphragm shaft fastener loosens.

1. On the side of the shaft (1a) opposite of the wrench flat, install the air-side plate (21), diaphragm backer (14), and diaphragm assembly (13, 15) into the shaft (1a). Firmly tighten.

NOTE: Regardless of any markings on the diaphragm backer (14), always assemble the diaphragm backer (14) so that the outer bead cups around (not away from) the outer bead of the diaphragm (13).

NOTE: Apply thread locker to the fastener (15) for all diaphragm assemblies.

- 1. Apply a medium-strength thread locker to the shaft side of the fastener to attach the diaphragm to the shaft.

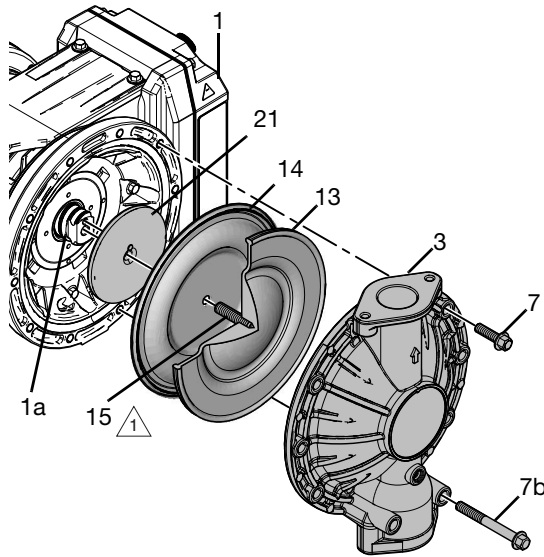

ti40627a

FIG. 23: Reassemble Overmolded Diaphragms

2. Use an applicable wrench to hold flat of the shaft (1a) firmly in place. At the same time, grip the diaphragm (13) securely around the outer edge and rotate clockwise to firmly tighten.
3. Rotate the shaft (1a) until it is centered in the motor (1).

NOTE: If it is not possible for both diaphragms to be in contact with the housing, choose one diaphragm to position first. Once the first fluid cover is fastened, slowly drive the motor so that the other diaphragm is in contact with the housing. Then fasten the second fluid cover.

4. On the side of the equipment with the installed diaphragm, align the fluid cover (3) to the motor (1).
5. Loosely install the fasteners (7, 7b, if applicable) to hold the fluid cover (3) in place.
6. On the side of the shaft (1a) with the wrench flat, install the air-side plate (21), diaphragm backer (14), and diaphragm assembly (13, 15) into the shaft (1a). Firmly tighten.
7. Align the fluid cover (3) to the motor (1).
8. Loosely install the fasteners (7, 7b, if applicable) to hold the fluid cover (3) in place.

NOTE: To ensure proper spacing and alignment of the manifolds (4, 5), install fasteners (7, 7b, if applicable) loose enough to allow for fluid cover movement before securing the fluid covers (3) in place.

9. Torque all fasteners (7, 7b, if applicable). Follow **Torque Fasteners**, page 49.
10. Reassemble the check valves and manifolds as explained in **Reassemble the Check Valves**, page 41.

- 5. See **Torque Fasteners**, page 49.

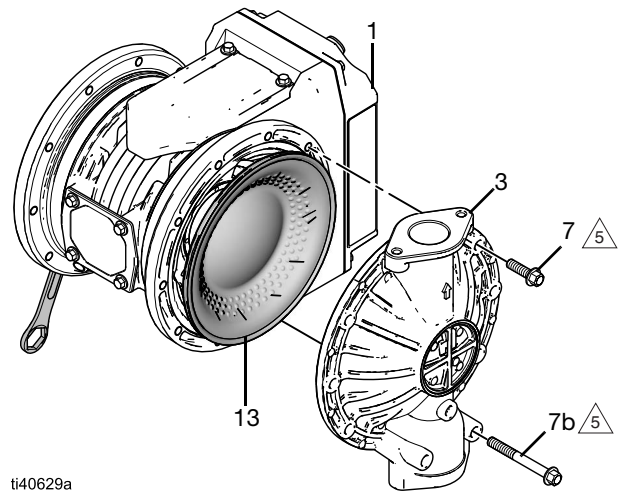

ti40629a

FIG. 24: Tighten Overmolded Diaphragms

Recycling and Disposal

End of Equipment Life

At the end of the useful life of the equipment, disassemble and recycle the equipment in a responsible manner.

- Follow **Pressure Relief Procedure**, page 29.
- Drain and dispose of fluids according to applicable regulations. See the Safety Data Sheet (SDS) of the material manufacturer.
- Remove motors, circuit boards, LCDs (liquid crystal displays), and other electronic components. Recycle according to applicable regulations.
- Do not dispose of electronic components with household or commercial waste.



- Deliver remaining equipment to a recycling facility.

Torque Fasteners

Torque Instructions

To ensure proper sealing, torque fasteners using the following procedure.

1. Start all fasteners a few turns.
2. Follow the torque sequence to turn down each fastener until each fastener is slightly under the specified torque. See **Torque Sequence**, page 49.
3. Follow the torque sequence to turn each fastener by 1/2 turn or less until each fastener is at the specified torque. See **Torque Sequence**, page 49.

Torque Sequence

Fully torque all fasteners (6, 7, 7b, as applicable) on the fluid covers (3) before torquing the fasteners (6, 6b, if applicable) on the manifolds (4, 5).

Follow **Torque Instructions**, page 49.

NOTICE

To avoid pump damage, do not over-torque the fasteners on the equipment.

Torque Sequence for i30 (QTC) Models

Fluid Covers (3)

For i30 plastic models: Torque fasteners (7, 7b, if applicable) to 90 in-lb (10 N•m).

For i30 metal models: Torque fasteners (7, 7b, if applicable) to 110 in-lb (12 N•m).

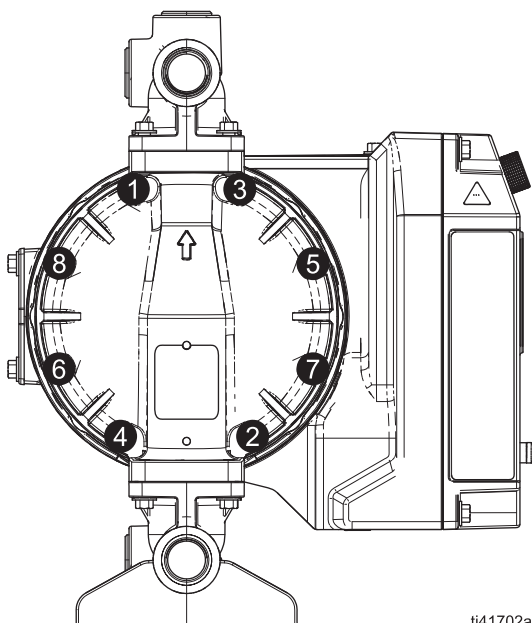

ti41702a

Manifolds (4, 5)

For i30 plastic models: Torque fasteners (6, 6b, if applicable) to 90 in-lb (10 N•m)

For i30 metal models: Torque fasteners (6, 6b, if applicable) to 110 in-lb (12 N•m).

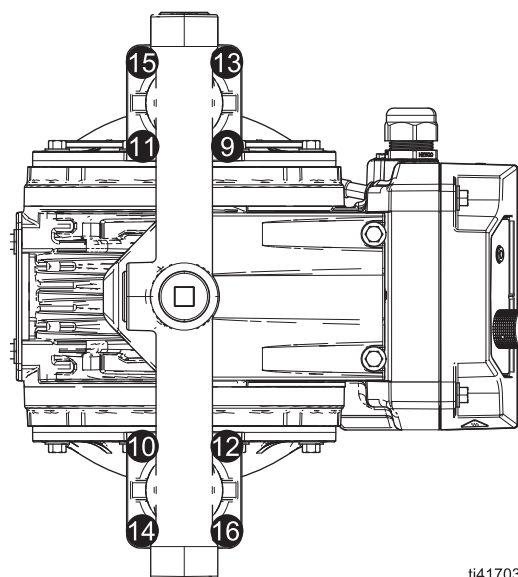

ti41703e

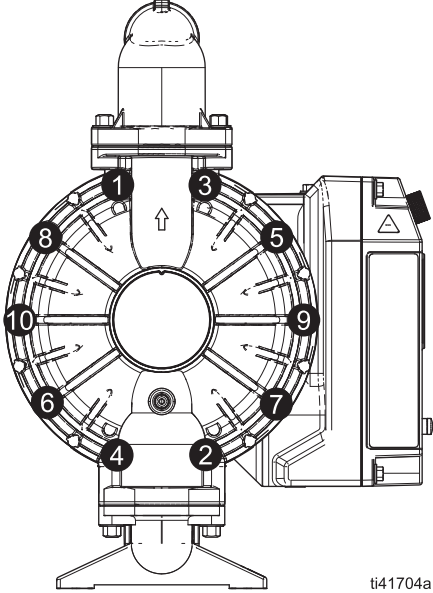
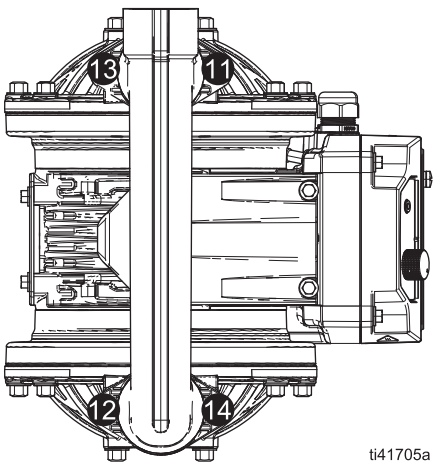
Torque Sequence for i80 (QTD) Models	
Fluid Covers (3)	Manifolds (4, 5)
<p>Torque fasteners (7, 7b, if applicable) to 190–220 in-lb (21–25 N•m).</p>	<p>For i80 (QTD) plastic models: Torque fasteners (6, 6b, if applicable) to 80–90 in-lb (9–10 N•m).</p> <p>For i80 (QTD) metal models: Torque fasteners (6, 6b, if applicable) to 120–150 in-lb (14–17 N•m).</p>
 <p style="text-align: right; font-size: small;">ti41704a</p>	 <p style="text-align: right; font-size: small;">ti41705a</p>

Torque Sequence for i120 (QTE) Ball Models

Fluid Covers (3)	Manifolds (4, 5)
<p>Torque fasteners (7, 7b, if applicable) to 190–220 in-lb (21–25 N•m).</p>	<p>For i120 (QTE) plastic models: Torque fasteners (6, 6b, if applicable) to 150–160 in-lb (17–18 N•m).</p> <p>For i120 (QTE) aluminum models: Torque fasteners (6, 6b, if applicable) to 120–150 in-lb (14–17 N•m).</p> <p>For i120 (QTE) metal models, except aluminum: Torque fasteners (6, 6b, if applicable) to 190–220 in-lb (21–25 N•m).</p>

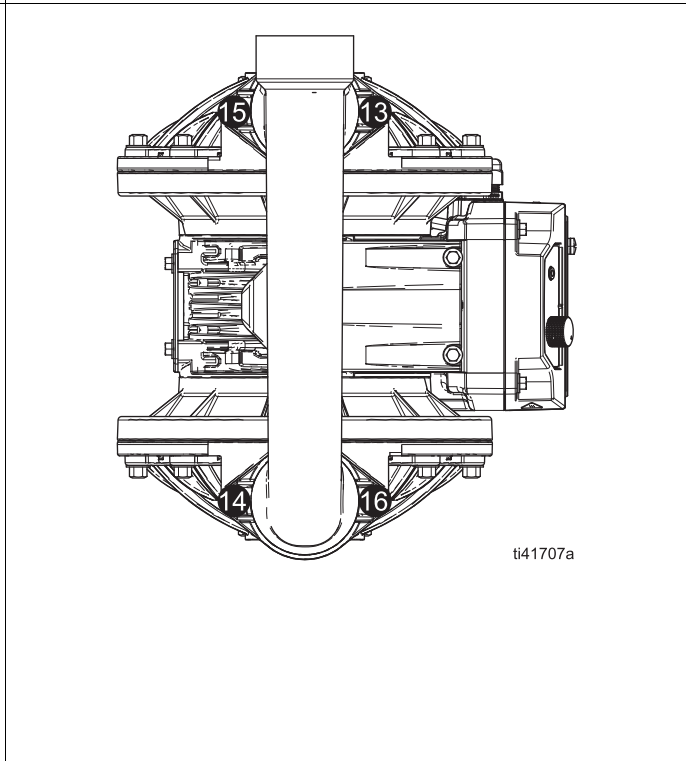
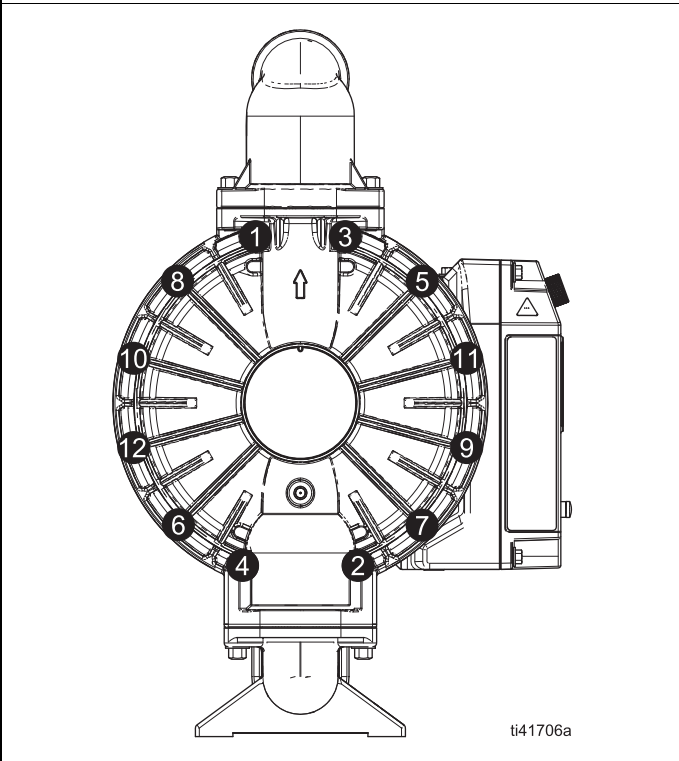

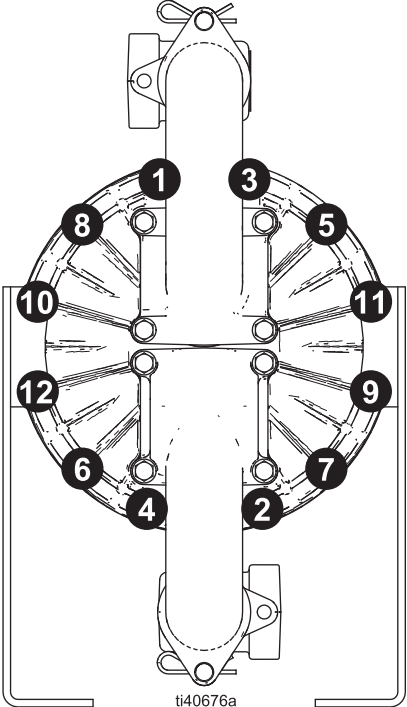
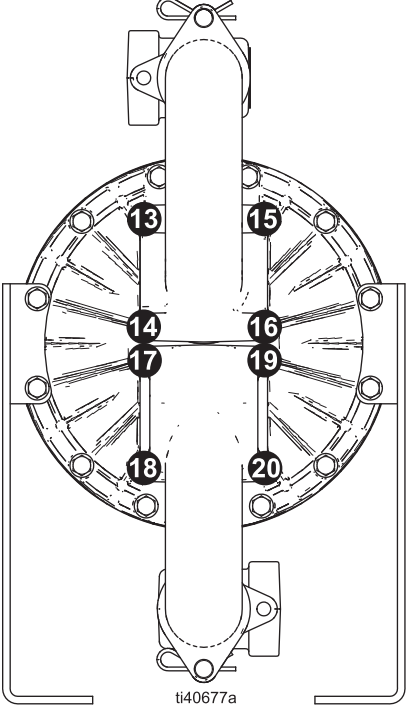
Torque Sequence for i120 (QTE) Flapper Models	
Fluid Covers	Manifolds
Torque to 190–220 in-lb (21–25 N•m)	Torque to 190–220 in-lb (21–25 N•m)
 <p style="text-align: center; margin-top: 10px;">ti40676a</p>	 <p style="text-align: center; margin-top: 10px;">ti40677a</p>

Performance Charts

Performance may vary based on pump materials, suction condition, discharge pressure, and fluid type.

Reference	Control Knob Setting
A	100%
B	80%
C	60%
D	40%
E	20%

Performance Chart for i30 (QTC) Models

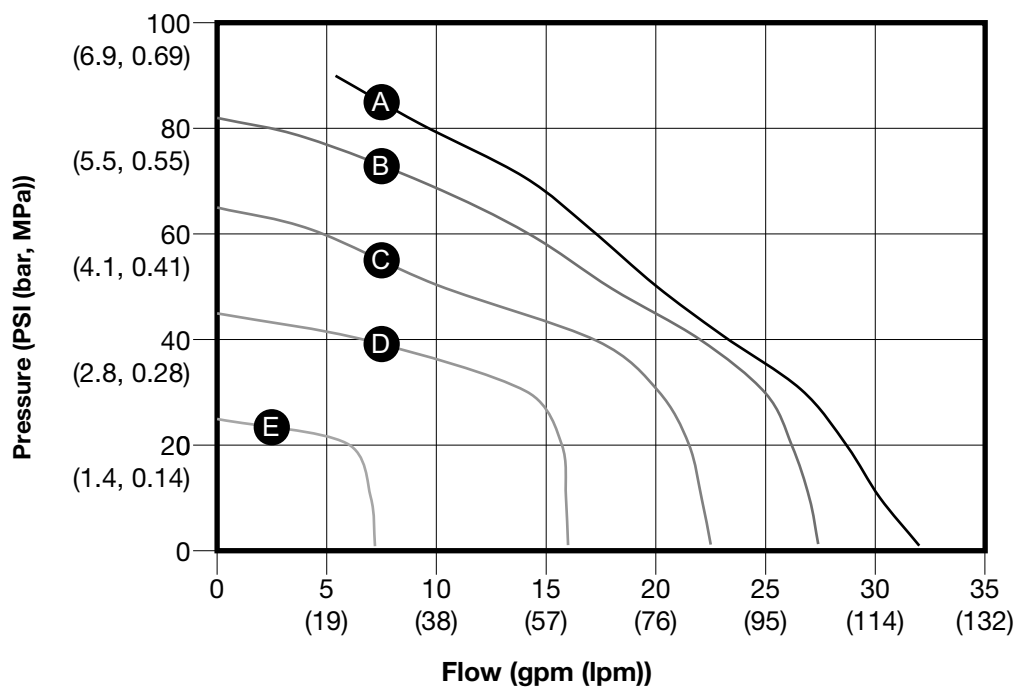

Performance Chart for i80 (QTD) Models

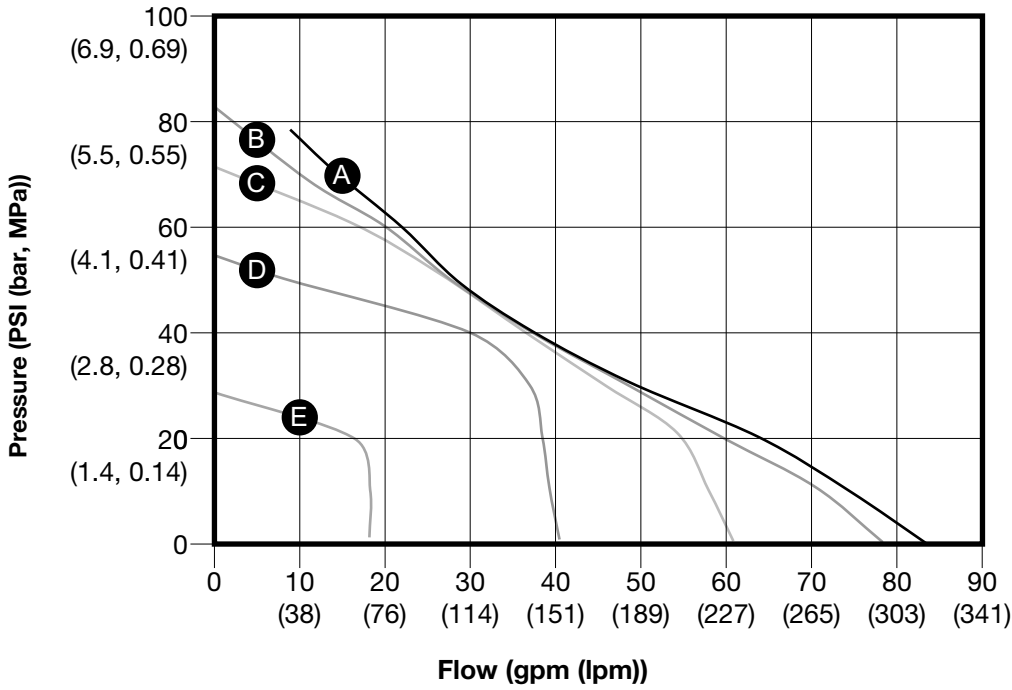

Performance Chart for i120 (QTE) Ball Models

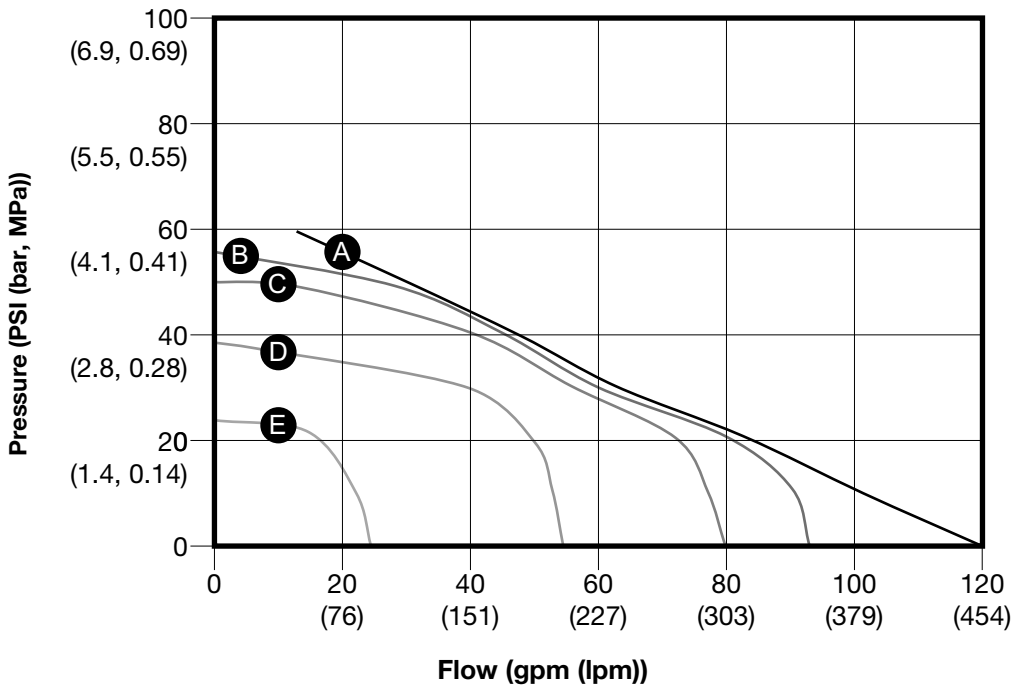

Performance Chart for i120 (QTE) Flapper Models

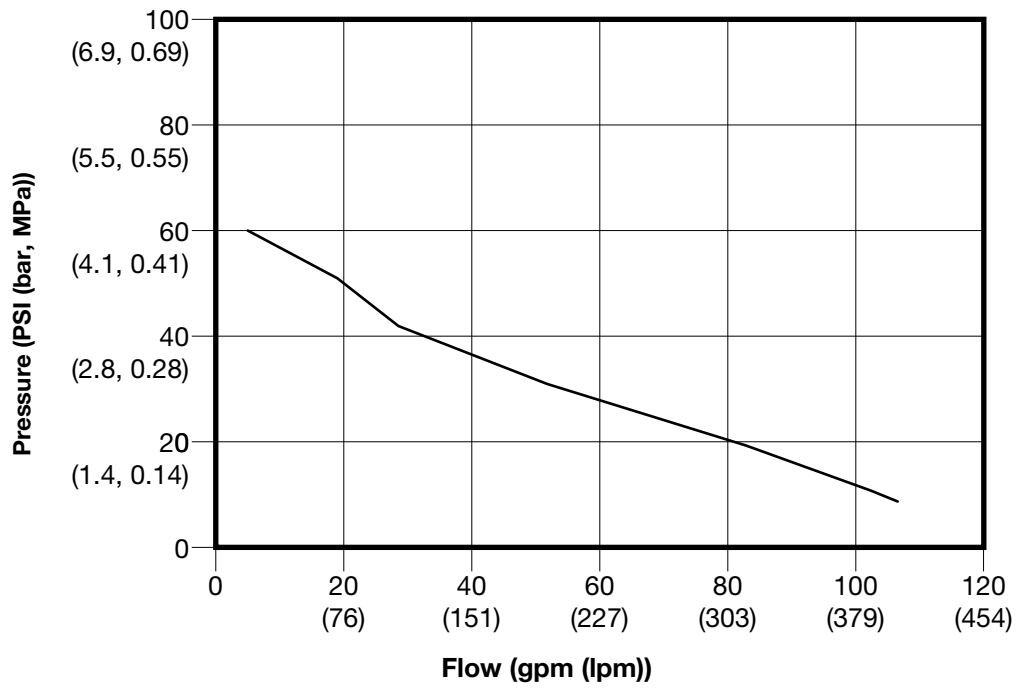

Dimensions

Dimensions for i30 (QTC) Models

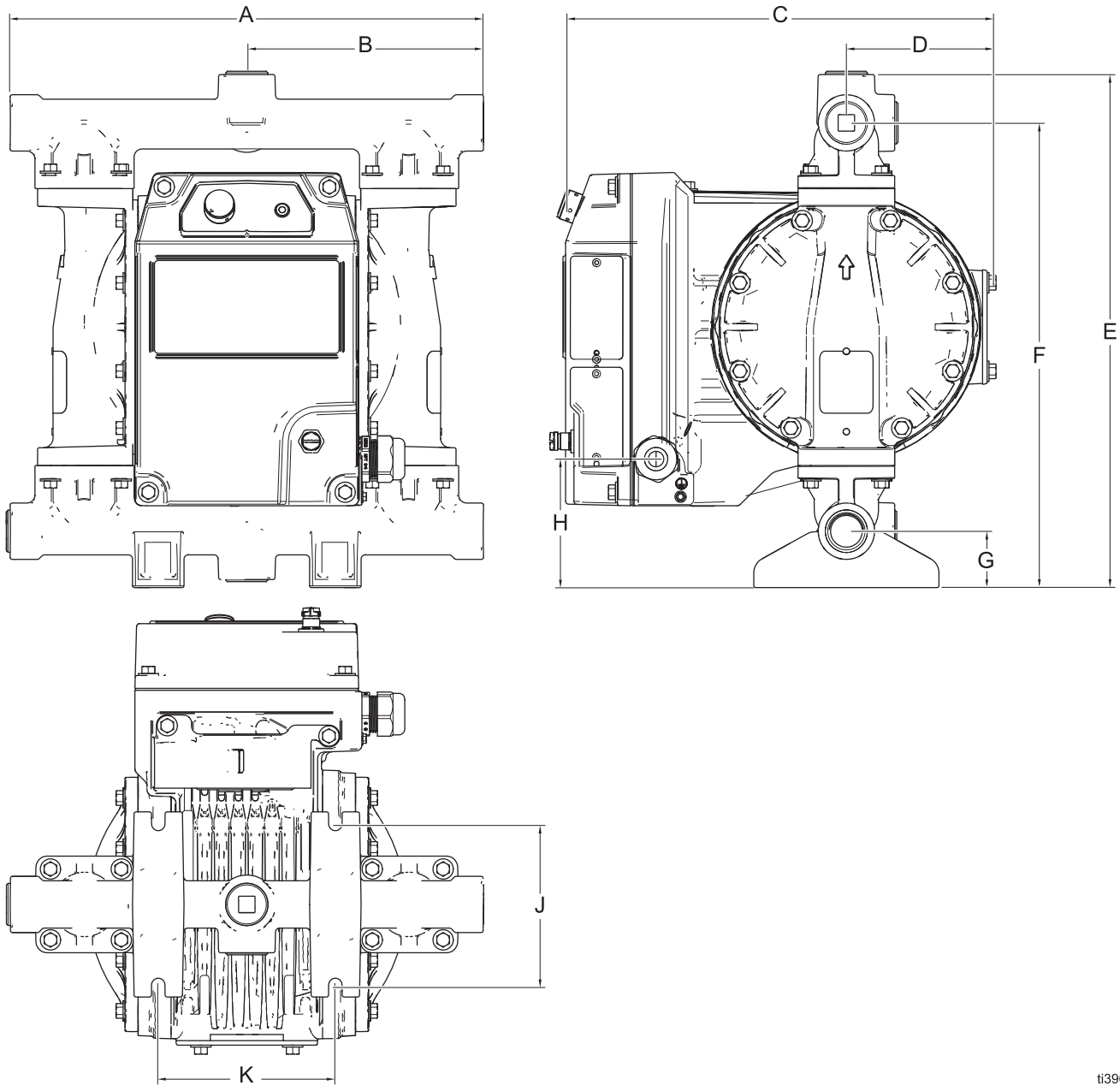

ti39017e

FIG. 25: Dimension Diagram for i30 (QTC) with Metal Wetted Section

Dimensions for i30 (QTC) Model with Metal Wetted Section				
Ref.	Wetted Section Material			
	AL		SS	
	in.	cm	in.	cm
A	14.70	37.34	13.90	35.31
B	7.35	18.67	6.58	16.71
C	13.25	33.66	13.25	33.66
D	4.57	11.61	4.57	11.61
E	15.94	40.49	13.70	34.80
F	14.44	36.68	12.90	32.77
G	1.76	4.47	1.10	2.79
H	3.70	9.40	2.20	5.59
J	5.00	12.70	5.00	12.70
K	5.50	13.97	5.50	13.97

Dimensions

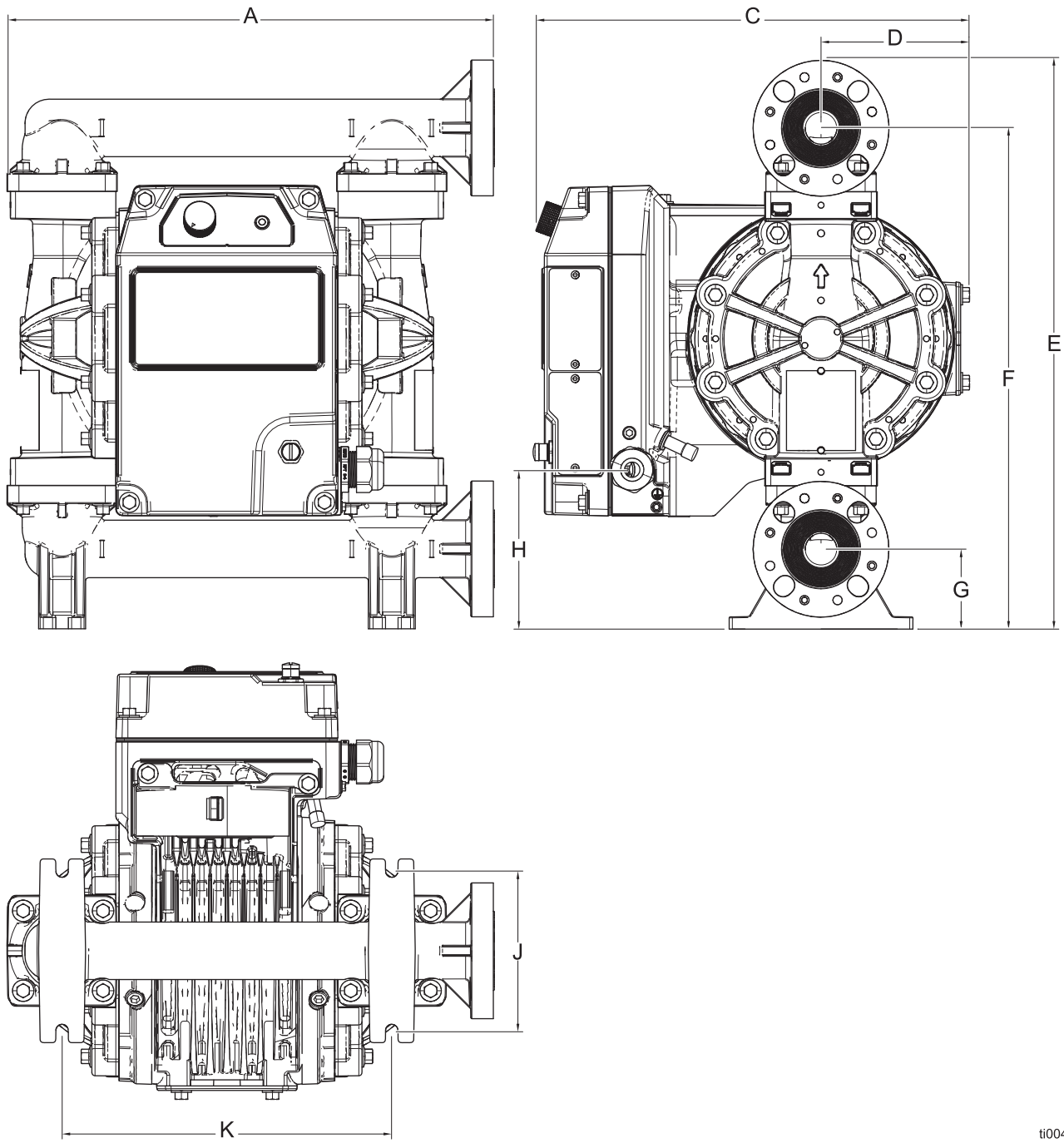

ti00460a

FIG. 26: Dimension Diagram for i30 (QTC) with Plastic Wetted Section, End Flange

Dimensions for i30 (QTC) Model with Plastic Wetted Section, End Flange						
Ref.	Wetted Section Material					
	CP		PP		PV	
	in.	cm	in.	cm	in.	cm
A	15.20	38.61	15.20	38.61	15.20	38.61
C	13.25	33.66	13.25	33.66	13.25	33.66
D	4.57	11.61	4.57	11.61	4.57	11.61
E	17.80	45.21	17.80	45.21	17.80	45.21
F	15.70	39.88	15.70	39.88	15.70	39.88
G	2.50	6.35	2.50	6.35	2.50	6.35
H	4.69	11.91	4.69	11.91	4.69	11.91
J	5.00	12.70	5.00	12.70	5.00	12.70
K	10.55	26.8	10.42	26.50	10.37	26.34

Dimensions

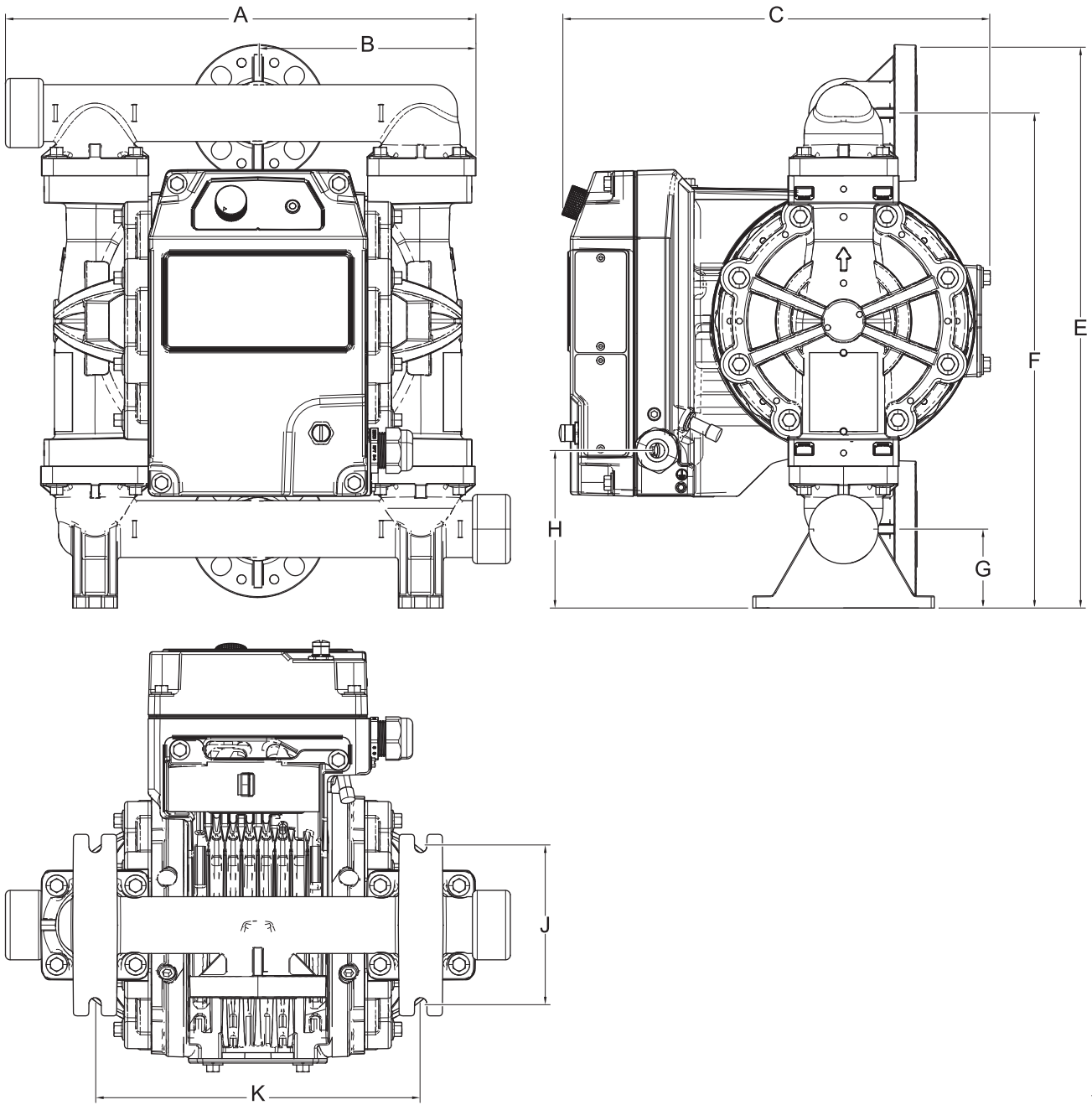

ti00470a

FIG. 27: Dimension Diagram for i30 (QTC) Model with Plastic Wetted Section (Center Flange)

Dimensions for i30 (QTC) Model with Plastic Wetted Section, Center Flange						
Ref.	Wetted Section Material					
	CP		PP		PV	
	in.	cm	in.	cm	in.	cm
A	16.0	40.60	16.0	40.60	16.0	40.60
B	8.00	20.32	8.00	20.32	8.00	20.32
C	13.25	33.66	13.25	33.66	13.25	33.66
D	4.57	11.61	4.57	11.61	4.57	11.61
E	17.80	45.21	17.80	45.21	17.80	45.21
F	15.70	39.88	15.70	39.88	15.70	39.88
G	2.50	6.35	2.50	6.35	2.50	6.35
H	4.69	11.91	4.69	11.91	4.69	11.91
J	5.00	12.70	5.00	12.70	5.00	12.70
K	10.55	26.80	10.42	26.50	10.37	26.34

Dimensions for i80 (QTD) Models

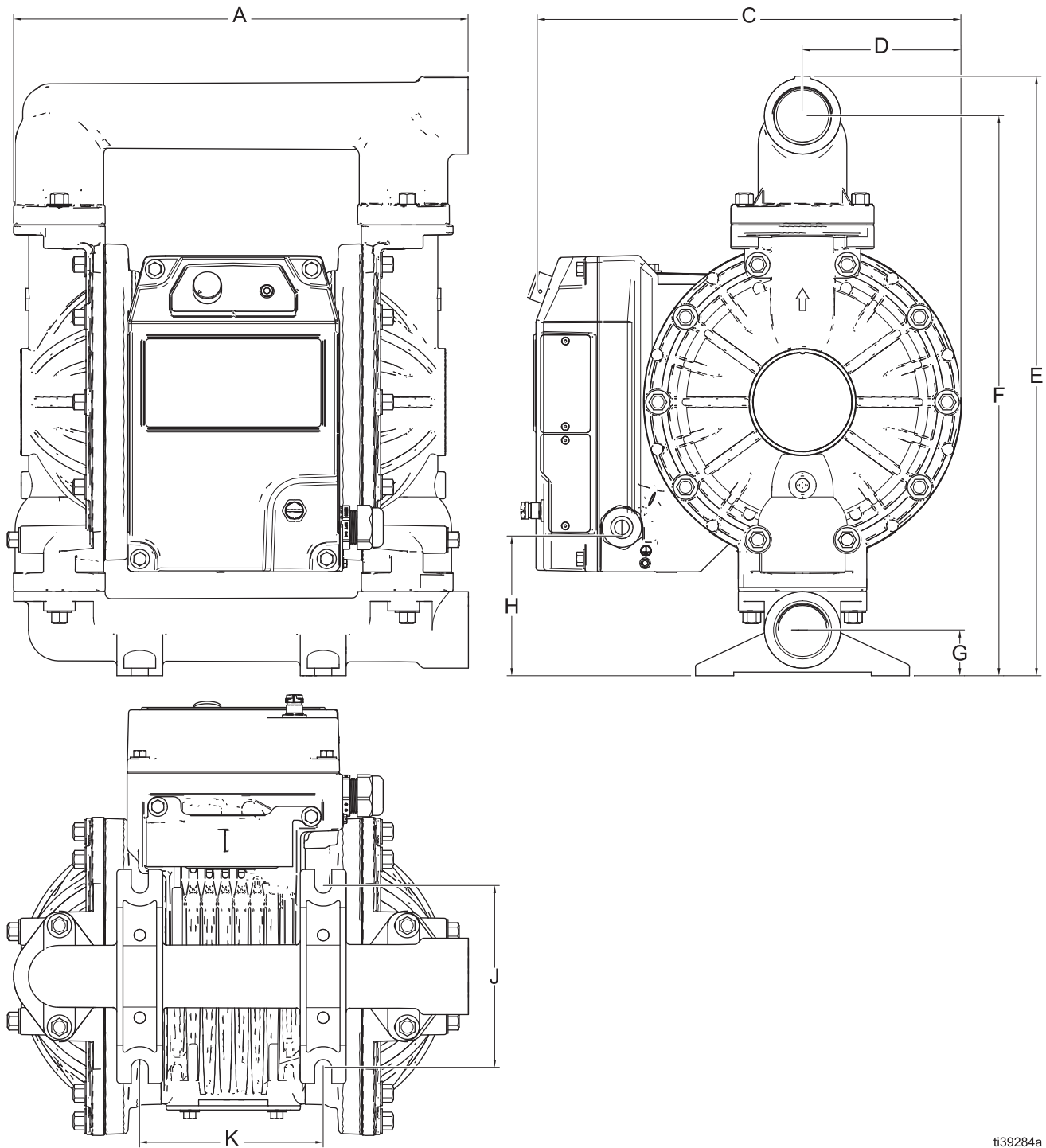

ti39284a

FIG. 28: Dimension Diagram for i80 (QTD) Model with Metal Wetted Section

Dimensions for i80 (QTD) Model with Metal Wetted Section				
Ref.	Wetted Section Material			
	AL		SS	
	in.	cm	in.	cm
A	15.07	38.28	16.10	40.89
C	13.81	35.08	13.85	35.18
D	5.17	13.13	5.21	13.23
E	19.60	49.78	18.97	48.18
F	18.30	46.48	17.75	45.09
G	1.50	3.81	1.44	3.66
H	4.55	11.56	4.55	11.56
J	6.00	15.24	6.00	15.24
K	6.00	15.24	6.00	15.24

Dimensions

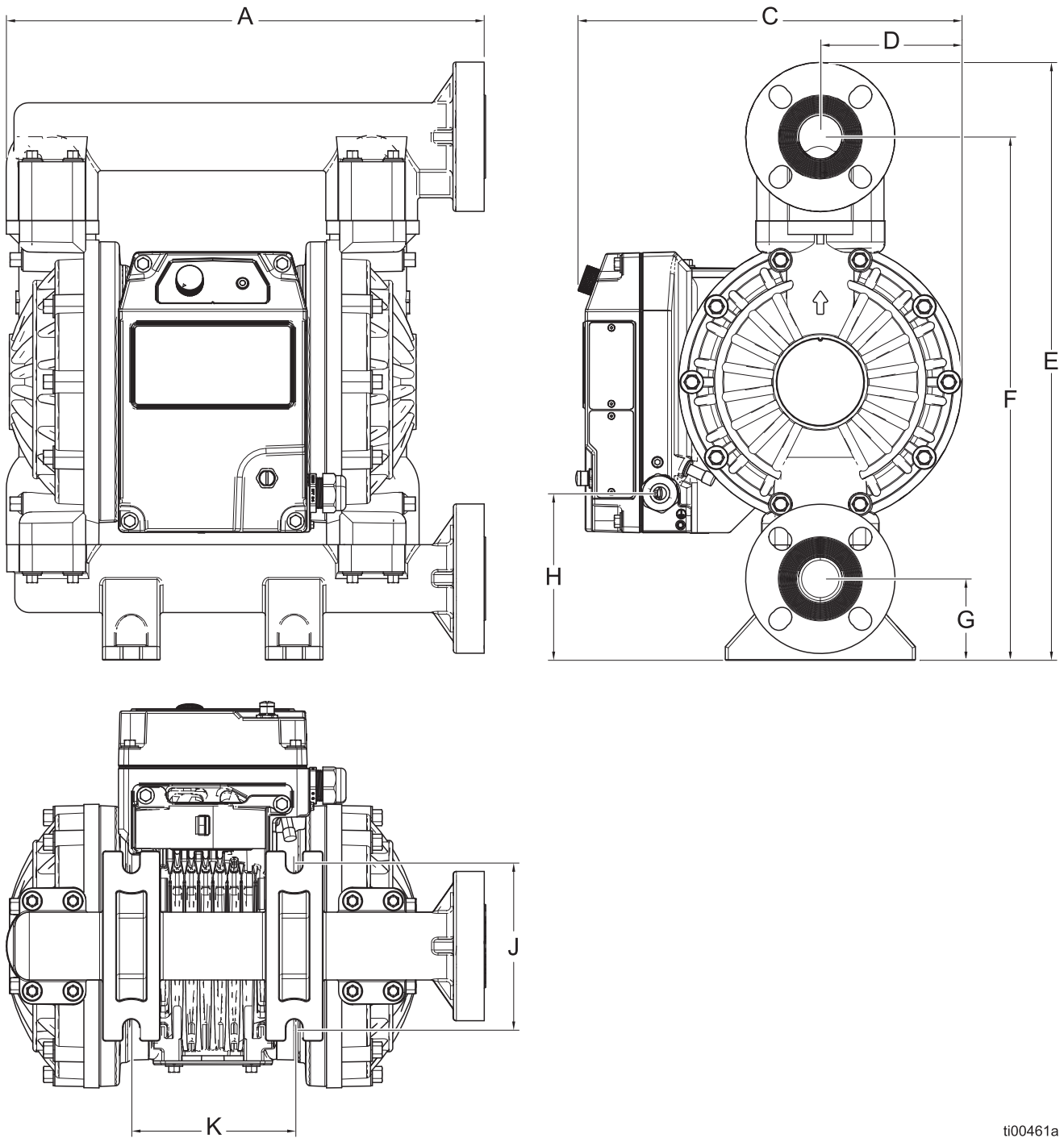

ti00461a

FIG. 29: Dimension Diagram for i80 Model (QTD) with Plastic Wetted Section

Dimensions for i80 (QTD) Model with Plastic Wetted Section		
Ref.	Wetted Section Material	
	PP, PV	
	in.	cm
A	17.60	44.70
C	13.87	35.23
D	5.23	13.28
E	22.00	55.88
F	19.30	49.02
G	3.00	7.62
H	5.85	14.86
J	6.00	15.24
K	6.00	15.24

Dimensions for i120 (QTE) Ball Models

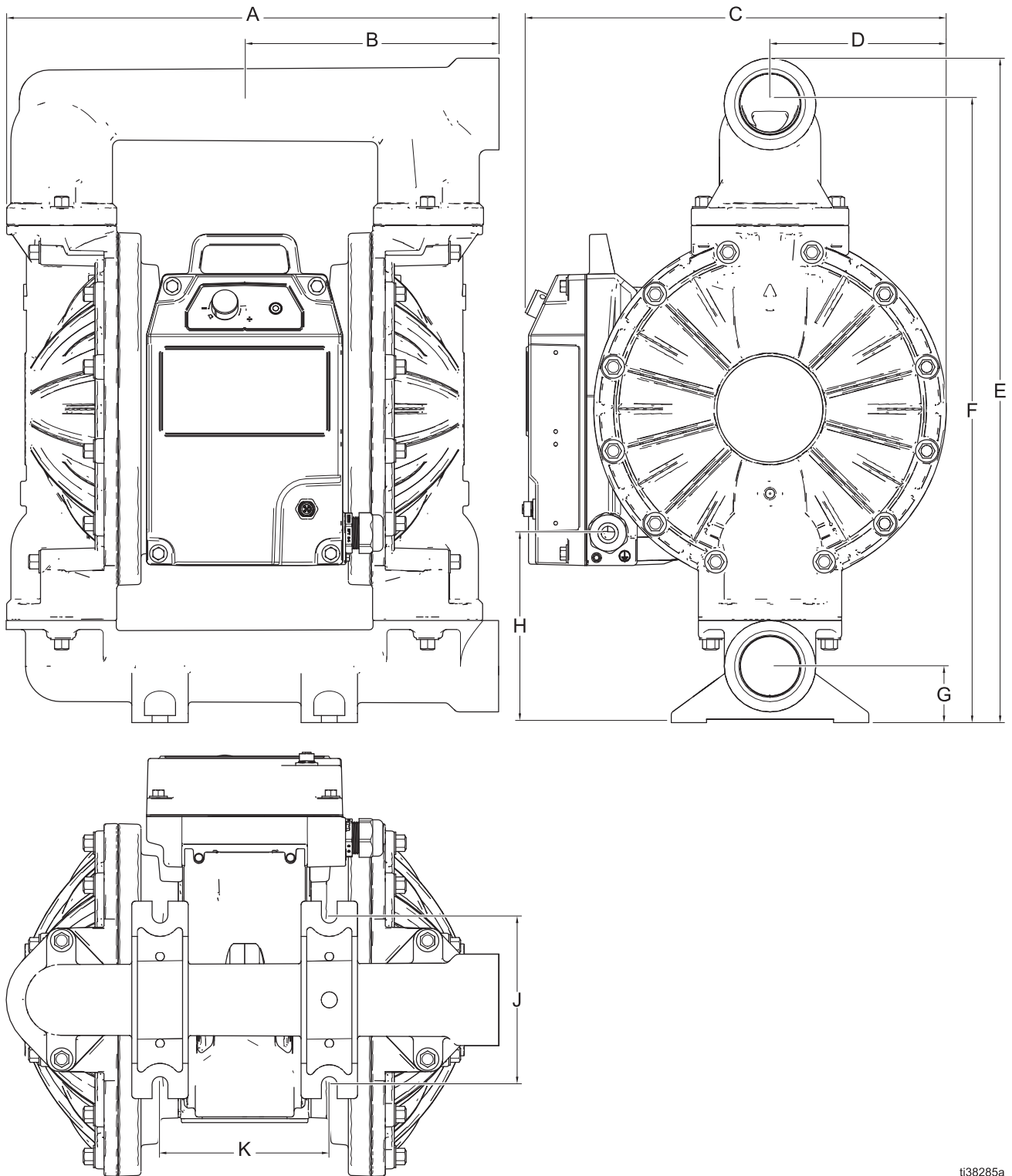

i138285a

FIG. 30: Dimension Diagram for i120 (QTE) Ball Models with Metal Wetted Section

Dimensions for i120 (QTE) Ball Model with Metal Wetted Section				
Ref.	Wetted Section Material			
	AL		Cl, SS	
	in.	cm	in.	cm
A	17.50	44.45	18.13	46.05
B	9.00	22.86	9.40	23.88
C	14.89	37.82	14.89	37.82
D	6.25	15.88	6.25	15.88
E	23.60	59.94	26.34	66.90
F	21.90	55.63	24.79	62.97
G	2.00	5.08	2.50	6.35
H	6.72	17.07	9.01	22.89
J	6.00	15.24	6.00	15.24
K	6.00	15.24	6.50	16.51

Dimensions

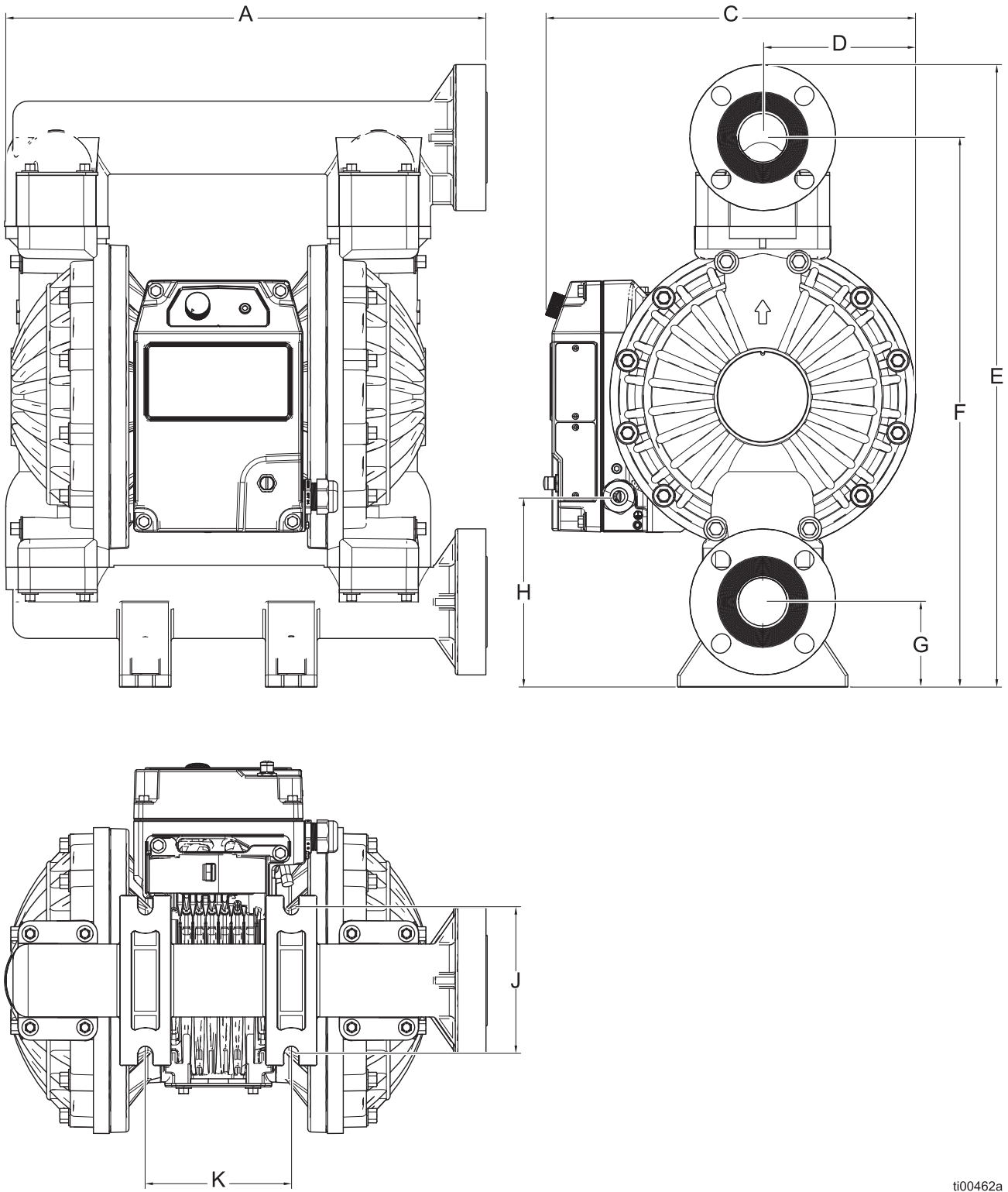

ti00462a

FIG. 31: Dimension Diagram for i120 Ball Models with Plastic Wetted Section

Dimensions for i120 (QTE) Ball Model with Plastic Wetted Section		
Ref.	Wetted Section Material	
	CP, PP, PV	
	in.	cm
A	19.70	50.04
C	14.89	37.82
D	6.25	15.88
E	25.70	65.28
F	22.70	57.66
G	3.50	8.89
H	7.53	19.13
J	6.00	15.24
K	6.00	15.24

Dimensions for i120 (QTE) Flapper Models

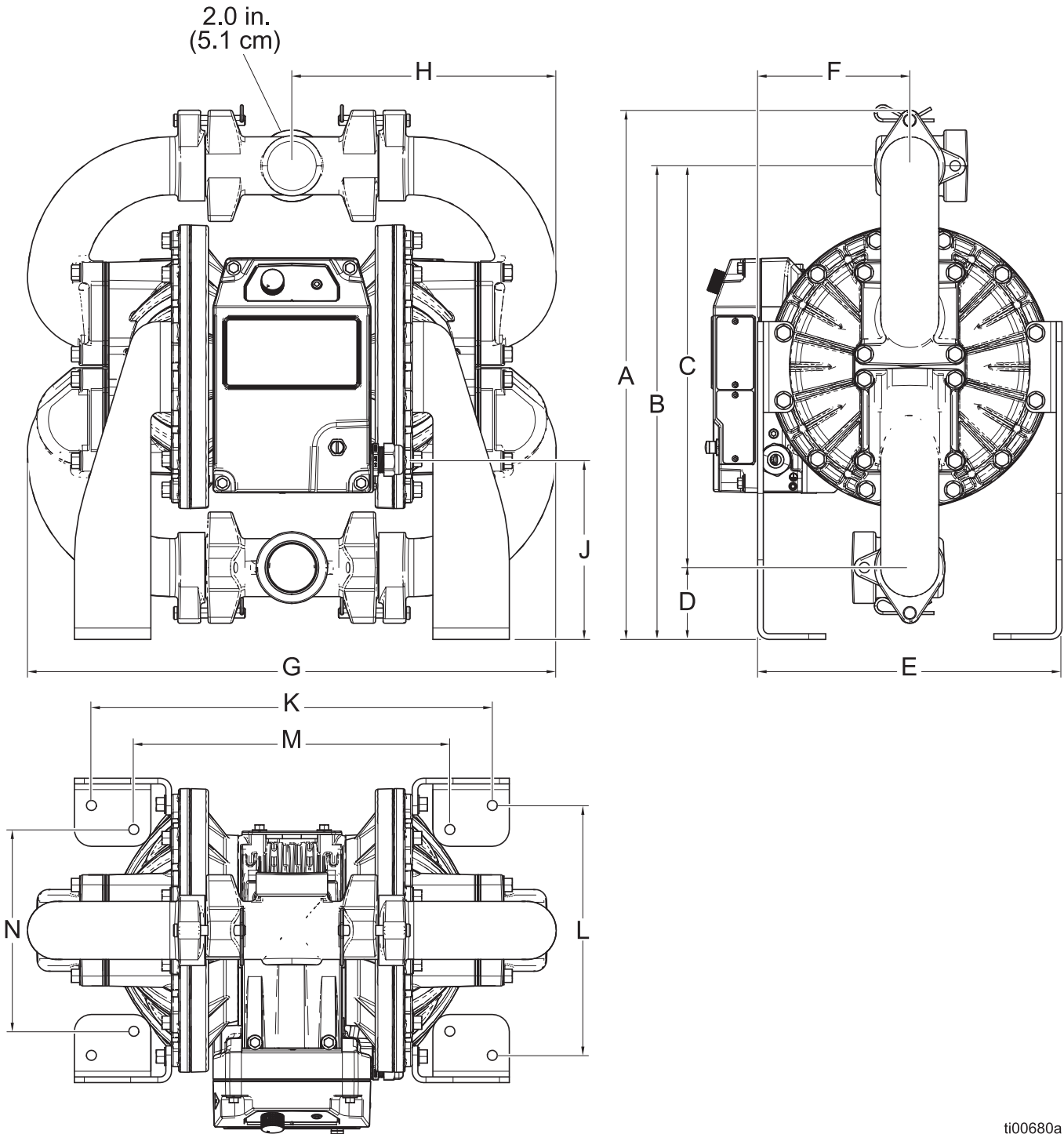

ti00680a

FIG. 32: Dimension Diagram for i120 (QTE) Flapper Models with Metal Wetted Section

Dimensions for i120 (QTE) Flapper Model with Metal Wetted Section		
Ref.	Wetted Section Material	
	AL	
	in.	cm
A	23.31	59.2
B	20.86	53.0
C	17.73	45.0
D	3.16	8.0
E	13.40	34.0
F	6.70	17.0
G*	23.29	59.2
H*	11.64	29.6
J	7.91	20.1
K*	17.89	44.9
L	11.01	28.0
M*	13.95	35.4
N	8.89	22.6

* Dimensions can vary by up to 0.25 in. (6.3 mm) depending on the diaphragm material fitted in the equipment.

Technical Specifications

Fluid Temperature Range

NOTICE

Temperature limits are based on mechanical stress only. Certain chemicals will further limit the fluid temperature range. Stay within the temperature range of the most-restricted wetted component. Operating at a fluid temperature that is too high or too low for the components of your pump may cause equipment damage.

NOTE: The maximum fluid temperature for Hazardous units should not exceed 230°F (110°C) or the limitation based on the Wetted Section Materials, whichever is lower.

Not all materials in this table are available in all models.

Material of Wetted Contact Section Parts (Seat, Check, Diaphragm)*	Fluid Temperature Range by Wetted Section Material					
	Metal (AL, CI, CP, FG, HS, HT, PH, SS, 3A)*		Plastic (PV)*		Plastic (AC, CP, PP)*	
	Fahrenheit	Celsius	Fahrenheit	Celsius	Fahrenheit	Celsius
(AC) Acetal	-20° to 180°	-29° to 82°	10° to 180°	-12° to 82°	32° to 150°	0° to 66°
(AL) Aluminum	-60° to 275°	-51° to 135°				
(BN) Buna-N	10° to 180°	-12° to 82°				
(CO) Polychloroprene Overmold	10° to 180°	-12° to 82°				
(CR) Polychloroprene, standard, ball	10° to 180°	-12° to 82°				
(CW) Polychloroprene, weighted, ball	10° to 180°	-12° to 82°				
(EO) EPDM Overmolded	-40° to 250°	-40° to 121°	N/A		N/A	
(-B) Buna-N Overmold 303 Stainless Steel, flapper	10° to 180°	-12° to 82°	N/A		N/A	
(FB) 303 Stainless Steel with Buna-N seals	10° to 180°	-12° to 82°	N/A		N/A	
(FK) Fluoroelastomer	-40° to 275°	-40° to 135°	10° to 180°	-12° to 82°	32° to 150°	0° to 66°
(FL) Flapper (SS)	-60° to 275°	-51° to 135°				
(GE) Graco Engineered Thermoplastic	-40° to 180°	-40° to 82°				
(PO) PTFE/EPDM Overmolded	-40° to 180°	-40° to 82°				
(PP) Polypropylene	32° to 175°	0° to 79°				
(PS) PTFE/Santo 2-piece	-40° to 180°	-40° to 82°				
(PV) PVDF	10° to 225°	-12° to 107°	32° to 175°	0° to 79°		
			10° to 180°	-12° to 82°		

Material of Wetted Contact Section Parts (Seat, Check, Diaphragm)*	Fluid Temperature Range by Wetted Section Material					
	Metal (AL, CI, CP, FG, HS, HT, PH, SS, 3A)*		Plastic (PV)*		Plastic (AC, CP, PP)*	
	Fahrenheit	Celsius	Fahrenheit	Celsius	Fahrenheit	Celsius
(SA) 17-4PH SST w/PTFE o-rings	-40° to 220°	-40° to 104°				
(SD) 440C Stainless Steel	-40° to 220°	-40° to 104°				
(SO) Santoprene Overmolded	-40° to 180°	-40° to 82°	10° to 180°	-12° to 82°	32° to 150°	0° to 66°
(SP) Santoprene	-40° to 180°	-40° to 82°				
(SS) 316 Stainless Steel	-60° to 275°	-51° to 135°				
(TP) TPE	-20° to 150°	-29° to 66°	10° to 150°	-12° to 66°	32° to 150°	0° to 66°

* See **Configuration Matrix**, starting on page 9, for detailed descriptions.

Technical Specifications for i30 (QTC) Models

QUANTM i30 (QTC) Pumps				
	US		Metric	
Maximum fluid working pressure	100 psi		6.89 bar, 0.69 MPa	
Maximum free-flow delivery	30 gpm		114 lpm	
Maximum size pumpable solids	0.125 in.		3.2 mm	
Fluid flow*	0.08 gal/cycle		0.30 l/cycle	
Environmental temperature range	-4° to 104°F		-20° to 40°C	
Maximum operating altitude	9842 ft		3000 m	
IP rating, ordinary locations models			IP66	
IP rating, explosive atmospheres or hazardous (classified) locations models			IP66	
Electrical ratings				
	Rated Voltage	Phase	Hertz	Current
i30 (QTC) models, FC2 motor	200–240 V	1	50/60 Hz	10 A
i30 (QTC) models, FC4 motor	200–240 V	1	50/60 Hz	10 A
i30 (QTC) models, FC5 motor	100–120 V	1	50/60 Hz	12 A
i30 (QTC) models, FC6 motor	100–120 V	1	50/60 Hz	12 A
Materials of construction				
See Configuration Matrix , starting on page 9, for materials of construction for your equipment model.				
Fluid inlet/outlet sizes				
Models with wetted section materials coded:				
	AL, SS, HT	1 in. npt(f) or 1 in. bspt		
	CP, PP, PV, SS with S51 connection	DIN PN10 025–1 in. ANSI 150 1 NPS		
Maximum suction lift*				
	Wet	29.0 ft	8.8 m	
	Dry	7.9 ft	2.4 m	
Noise (dBa)				
Maximum sound pressure		74 dBa at full power and flow		
<i>Sound pressure measured 1.6 feet (0.5 meter) from equipment.</i>				
Weight				
Models with wetted section materials coded:				
	AL	62 lb	28.1 kg	
	SS	79 lb	35.8 kg	
	HT	79 lb	35.8 kg	
	CP, PP	61 lb	27.7 kg	
	PV	67 lb	30.4 kg	
Notes				
* May vary based on pump materials, suction condition, discharge head, pressure, and fluid type.				
All trademarks or registered trademarks are the property of their respective owners.				

Technical Specifications for i80 (QTD) Models

QUANTM i80 (QTD) Pumps				
	US		Metric	
Maximum fluid working pressure	100 psi		6.89 bar, 0.69 MPa	
Maximum free-flow delivery	80 gpm		300 lpm	
Maximum size pumpable solids	0.19 in.		4.8 mm	
Fluid flow*	0.42 gal/cycle		1.59 l/cycle	
Environmental temperature range	-4° to 104°F		-20° to 40°C	
Maximum operating altitude	9842 ft		3000 m	
IP rating, ordinary locations models			IP66	
IP rating, explosive atmospheres or hazardous (classified) locations models			IP66	
Electrical ratings				
	Rated Voltage	Phase	Hertz	Current
i80 (QTD) models, FC1 motor	200–240 V	3	50/60 Hz	7.5 A
i80 (QTD) models, FC2 motor	200–240 V	1	50/60 Hz	15 A
i80 (QTD) models, FC3 motor	200–240 V	3	50/60 Hz	7.5 A
i80 (QTD) models, FC4 motor	200–240 V	1	50/60 Hz	15 A
Materials of construction				
See Configuration Matrix , starting on page 9, for materials of construction for your equipment model.				
Fluid inlet/outlet sizes				
Models with wetted section materials coded:				
AL, SS	1.5 in. npt(f) or 1.5 in. bspt			
PP, PV	DIN PN10 040–1-1/2 in. ANSI 150 1-1/2 NPS			
Maximum suction lift*				
	Wet	29.0 ft	8.8 m	
	Dry	19.3 ft	5.9 m	
Noise (dBa)				
Maximum sound pressure	74 dBa at full power and full flow			
<i>Sound pressure measured 1.6 feet (0.5 meter) from equipment.</i>				
Weight				
Models with wetted section materials coded:				
AL	71 lb	32.2 kg		
SS	112 lb	50.8 kg		
CP, PP	75 lb	34.0 kg		
PV	85 lb	38.5 kg		
Notes				
* May vary based on pump materials, suction condition, discharge head, pressure, and fluid type.				
All trademarks or registered trademarks are the property of their respective owners.				

Technical Specifications for i120 (QTE) Ball Models

QUANTM i120 (QTE) Ball Pumps				
	US		Metric	
Maximum fluid working pressure	60 psi		4.1 bar, 0.41 MPa	
Maximum free-flow delivery	120 gpm		454 lpm	
Maximum size pumpable solids	0.25 in.		6.35 mm	
Fluid flow*	0.56 gal/cycle		2.12 l/cycle	
Environmental temperature range	-4° to 104°F		-20° to 40°C	
Maximum operating altitude	9842 ft		3000 m	
IP rating, Ordinary Locations models			IP66	
IP rating, Explosive Atmospheres or Hazardous (Classified) Locations models			IP66	
Electrical ratings				
	Rated Voltage	Phase	Hertz	Current
i120 (QTE) models, FC1 motor	200–240 V	3	50/60 Hz	7.5 A
i120 (QTE) models, FC2 motor	200–240 V	1	50/60 Hz	15 A
i120 (QTE) models, FC3 motor	200–240 V	3	50/60 Hz	7.5 A
i120 (QTE) models, FC4 motor	200–240 V	1	50/60 Hz	15 A
Materials of construction				
See Configuration Matrix , starting on page 9, for materials of construction for your equipment model.				
Fluid inlet/outlet sizes				
Inlet/Outlet size for models with wetted section materials coded:				
AL, CI, SS		2 in. npt(f) or 2 in. bspt		
CP, PP, PV, SS with S51 connection		DIN PN16 050–2 in. ANSI 150 2 NPS JIS 10K 50		
Maximum suction lift*				
	Wet	29.0 ft	8.8 m	
	Dry	15.9 ft	4.8 m	
Noise (dBa)				
Maximum sound pressure		77 dBa at full power and full flow		
<i>Sound pressure measured 1.6 feet (0.5 meter) from equipment.</i>				
Weight				
Models with wetted section materials coded:				
	AL	99 lb	44.9 kg	
	CI	165 lb	74.8 kg	
	SS	162 lb	73.5 kg	
	CP, PP	100 lb	45.4 kg	
	PV	117 lb	53.0 kg	
Notes				
* May vary based on pump materials, suction condition, discharge head, pressure, and fluid type.				
All trademarks or registered trademarks are the property of their respective owners.				

Technical Specifications for i120 (QTE) Flapper Models

QUANTM i120 (QTE) Flapper Pumps				
	US		Metric	
Maximum fluid working pressure	60 psi		4.1 bar, 0.41 MPa	
Maximum free-flow delivery	120 gpm		454 lpm	
Maximum size pumpable solids	1.8 in.		46 mm	
Fluid flow*	0.5 gal/cycle		1.9 l/cycle	
Environmental temperature range	-4° to 104°F		-20° to 40°C	
Maximum operating altitude	9842 ft		3000 m	
IP rating, Ordinary Locations models			IP66	
IP rating, Explosive Atmospheres or Hazardous (Classified) Locations models			IP66	
Electrical ratings				
	Rated Voltage	Phase	Hertz	Current
i120 (QTE) models, FC1 motor	200–240 V	3	50/60 Hz	7.5 A
i120 (QTE) models, FC2 motor	200–240 V	1	50/60 Hz	15 A
i120 (QTE) models, FC3 motor	200–240 V	3	50/60 Hz	7.5 A
i120 (QTE) models, FC4 motor	200–240 V	1	50/60 Hz	15 A
Materials of construction				
See Configuration Matrix , starting on page 9, for materials of construction for your equipment model.				
Fluid inlet/outlet sizes				
Inlet/Outlet size for models with wetted section materials coded:				
	AL	2 in. npt(f) or 2 in. bspt		
Maximum suction lift*				
	Wet	29.0 ft	8.8 m	
	Dry	15.9 ft	4.8 m	
Noise (dBa)				
Maximum sound pressure		77 dBa at full power and full flow		
<i>Sound pressure measured 1.6 feet (0.5 meter) from equipment.</i>				
Weight				
Models with wetted section materials coded:				
	AL	117 lb	53.1 kg	
Notes				
* May vary based on pump materials, suction condition, discharge head, pressure, and fluid type.				
All trademarks or registered trademarks are the property of their respective owners.				

California Proposition 65

CALIFORNIA RESIDENTS

 **WARNING:** Cancer and reproductive harm – www.P65warnings.ca.gov.

Graco Standard Warranty

Graco warrants all equipment referenced in this document which is manufactured by Graco and bearing its name to be free from defects in material and workmanship on the date of sale to the original purchaser for use. With the exception of any special, extended, or limited warranty published by Graco, Graco will, for a period of twelve months from the date of sale, repair or replace any part of the equipment determined by Graco to be defective. This warranty applies only when the equipment is installed, operated and maintained in accordance with Graco's written recommendations.

This warranty does not cover, and Graco shall not be liable for general wear and tear, or any malfunction, damage or wear caused by faulty installation, misapplication, abrasion, corrosion, inadequate or improper maintenance, negligence, accident, tampering, or substitution of non-Graco component parts. Nor shall Graco be liable for malfunction, damage or wear caused by the incompatibility of Graco equipment with structures, accessories, equipment or materials not supplied by Graco, or the improper design, manufacture, installation, operation or maintenance of structures, accessories, equipment or materials not supplied by Graco.

This warranty is conditioned upon the prepaid return of the equipment claimed to be defective to an authorized Graco distributor for verification of the claimed defect. If the claimed defect is verified, Graco will repair or replace free of charge any defective parts. The equipment will be returned to the original purchaser transportation prepaid. If inspection of the equipment does not disclose any defect in material or workmanship, repairs will be made at a reasonable charge, which charges may include the costs of parts, labor, and transportation.

THIS WARRANTY IS EXCLUSIVE, AND IS IN LIEU OF ANY OTHER WARRANTIES, EXPRESS OR IMPLIED, INCLUDING BUT NOT LIMITED TO WARRANTY OF MERCHANTABILITY OR WARRANTY OF FITNESS FOR A PARTICULAR PURPOSE.

Graco's sole obligation and buyer's sole remedy for any breach of warranty shall be as set forth above. The buyer agrees that no other remedy (including, but not limited to, incidental or consequential damages for lost profits, lost sales, injury to person or property, or any other incidental or consequential loss) shall be available. Any action for breach of warranty must be brought within two (2) years of the date of sale.

GRACO MAKES NO WARRANTY, AND DISCLAIMS ALL IMPLIED WARRANTIES OF MERCHANTABILITY AND FITNESS FOR A PARTICULAR PURPOSE, IN CONNECTION WITH ACCESSORIES, EQUIPMENT, MATERIALS OR COMPONENTS SOLD BUT NOT MANUFACTURED BY GRACO. These items sold, but not manufactured by Graco (such as electric motors, switches, hose, etc.), are subject to the warranty, if any, of their manufacturer. Graco will provide purchaser with reasonable assistance in making any claim for breach of these warranties.

In no event will Graco be liable for indirect, incidental, special or consequential damages resulting from Graco supplying equipment hereunder, or the furnishing, performance, or use of any products or other goods sold hereto, whether due to a breach of contract, breach of warranty, the negligence of Graco, or otherwise.

FOR GRACO CANADA CUSTOMERS

The Parties acknowledge that they have required that the present document, as well as all documents, notices and legal proceedings entered into, given or instituted pursuant hereto or relating directly or indirectly hereto, be drawn up in English. Les parties reconnaissent avoir convenu que la rédaction du présente document sera en Anglais, ainsi que tous documents, avis et procédures judiciaires exécutés, donnés ou intentés, à la suite de ou en rapport, directement ou indirectement, avec les procédures concernées.

Graco Information

For the latest information about Graco products, visit www.graco.com.

For patent information, see www.graco.com/patents.

TO PLACE AN ORDER, contact your Graco distributor or call to identify the nearest distributor.

Phone: 612-623-6921 **or Toll Free:** 1-800-328-0211, **Fax:** 612-378-3505

All written and visual data contained in this document reflects the latest product information available at the time of publication. Graco reserves the right to make changes at any time without notice.

Original instructions. This manual contains English. MM 3A8572

Graco Headquarters: Minneapolis

International Offices: Belgium, China, Japan, Korea

GRACO INC. AND SUBSIDIARIES • P.O. BOX 1441 • MINNEAPOLIS MN 55440-1441 • USA
Copyright 2022, Graco Inc. All Graco manufacturing locations are registered to ISO 9001.

www.graco.com
Revision G, December 2023