

QUANTMTM Electric Motor

3A7637E

EN

Electric-operated motor with integral electric drive. For use in QUANTM electric-operated diaphragm (EODD) pumps. For fluid transfer applications. For professional use only.



Important Safety Instructions

Read all warnings and instructions in this manual and related manuals before using the equipment. Save these instructions.

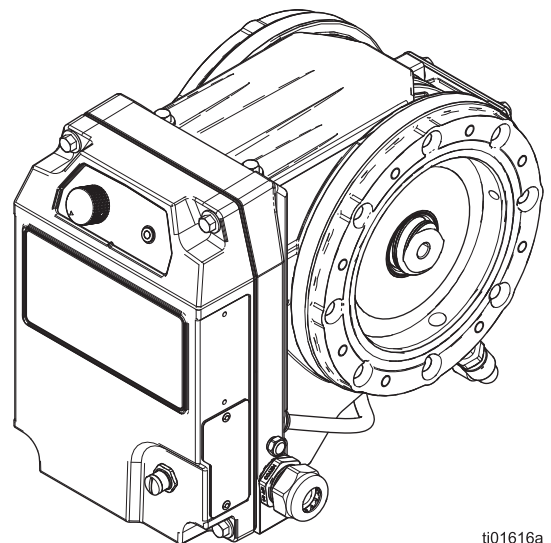

ti01616a

Contents

Related Manuals	2	Recycling and Disposal	35
Safety Symbols	3	Parts	36
Warnings	4	Parts List	39
Configuration Matrix	8	Kits and Accessories	41
Models and Approvals	12	Part Kits	41
Repair	14	Control Board Kits	43
Prepare Equipment for Repair	14	Accessory Kits	43
Torque Instructions	15	Electrical Schematics	44
Replace the Control Cover	16	Technical Specifications	45
Replace the Leak Sensor	17	California Proposition 65	45
Replace the Power Cord/Cable	22	Graco Standard Warranty	46
Repair the Fan Assembly	23		
Repair the Control Knob Assembly	26		
Replace the Control Board and Filter Board ...	27		
Replace the Motor Sensor	28		
Repair the Center Section	29		
Repair the Rotor and Shaft Assembly	30		
Recalibrate the Motor	34		







Related Manuals

English Manual Number	Description	Reference
3A8572	QUANTM Pumps, Instructions, Industrial Models	Pump Manual
3A9286	QUANTM Pumps, Instructions, Hygienic Models	Pump Manual
3A8946	QUANTM Pumps, Parts, Industrial Models	Parts Manual
3A9287	QUANTM Pumps, Parts, Hygienic Models	Parts Manual

Safety Symbols







The following safety symbols appear throughout this manual and on warning labels. Read the table below to understand what each symbol means.

Symbol	Meaning
	Burn Hazard
	Cleaning Solvent Hazard
	Electric Shock Hazard
	Equipment Misuse Hazard
	Fire and Explosion Hazard
	Entanglement Hazard
	Moving Parts Hazard
	Pressurized Equipment Hazard
	Splash Hazard
	Toxic Fluid or Fumes Hazard

Symbol	Meaning
	Ground Equipment
	Read Manual
	Follow Pressure Relief Procedure
	Ventilate Work Area
	Wear Personal Protective Equipment
	Do Not Wipe with a Dry Cloth
	Eliminate Ignition Sources

Warnings

The following warnings are for the setup, use, grounding, maintenance, and repair of this equipment. The exclamation point symbol alerts you to a general warning and the hazard symbols refer to procedure-specific risks. When these symbols appear in the body of this manual or on warning labels, refer back to these Warnings. Product-specific hazard symbols and warnings not covered in this section may appear throughout the body of this manual where applicable.

 <h2 style="margin: 0;">WARNING</h2>	
	<p>FIRE AND EXPLOSION HAZARD</p> <p>Flammable fumes, such as solvent and paint fumes, in work area can ignite or explode. Paint or solvent flowing through the equipment can cause static sparking. To help prevent fire and explosion:</p> <ul style="list-style-type: none"> • Use equipment only in well-ventilated area. • Eliminate all ignition sources; such as pilot lights, cigarettes, portable electric lamps, and plastic drop cloths (potential static sparking). • Ground all equipment in the work area. See Grounding instructions in your pump manual. • Keep work area free of debris, including solvent, rags and gasoline. • Do not plug or unplug power cords, or turn power or light switches on or off when flammable fumes are present. • Use only conductive grounded fluid lines. • Stop operation immediately if static sparking occurs or you feel a shock. Do not use equipment until you identify and correct the problem. • Keep a working fire extinguisher in the work area.
	
	
	
	<p>Static charge may build up on plastic parts during cleaning and could discharge and ignite flammable vapors. To help prevent fire and explosion:</p> <ul style="list-style-type: none"> • Clean plastic parts only in well-ventilated area. • Do not clean with a dry cloth.



WARNING

**ELECTRIC SHOCK HAZARD****Explosive Atmospheres or Hazardous (Classified) Locations Models (hard wired for permanent connection):**

This equipment must be grounded. Improper grounding, setup, or usage of the system can cause electric shock.



- Turn off and disconnect power at main switch before disconnecting any cables and before servicing or installing equipment.
- Connect only to grounded power source.
- All electrical wiring and repairs must be done by a qualified electrician and comply with all local codes and regulations.
- Store indoors.

Ordinary Locations Models (cord and plug connection):

This equipment must be grounded. Improper grounding, setup, or usage of the system can cause electric shock.











- Turn off and disconnect power cord before servicing equipment.
- Connect only to grounded electrical outlets.
- Only use 3-wire extension cords for 2-phase models. Only use 4-wire extension cords for 3-phase models.
- Ensure ground prongs are intact on power and extension cords.
- Store indoors.
- Wait five minutes after disconnecting power cord before servicing.

**EQUIPMENT MISUSE HAZARD**







Misuse can cause death or serious injury.



- Do not operate the unit when fatigued or under the influence of drugs or alcohol.
- Do not exceed the maximum working pressure or temperature rating of the lowest rated system component. See **Technical Specifications** in all equipment manuals.
- Use fluids and solvents that are compatible with equipment wetted parts. See **Technical Specifications** in all equipment manuals. Read fluid and solvent manufacturer's warnings. For complete information about your material, request Safety Data Sheets (SDSs) from distributor or retailer.
- Turn off all equipment and follow the **Pressure Relief Procedure** in your pump manual when equipment is not in use.
- Check equipment daily. Repair or replace worn or damaged parts immediately with genuine manufacturer's replacement parts only.
- Do not alter or modify equipment. Alterations or modifications may void agency approvals and create safety hazards.
- Make sure all equipment is rated and approved for the environment in which you are using it.
- Use equipment only for its intended purpose. Call your distributor for information.
- Route fluid lines, cords, and cables away from traffic areas, sharp edges, moving parts, and hot surfaces.
- Do not kink or over-bend fluid lines, cords, or cables. Do not use fluid lines, cords, or cables to pull equipment.
- Keep children and animals away from work area.
- Comply with all applicable safety regulations.

 <h1 style="margin: 0;">WARNING</h1>	
 	<p>PLASTIC PARTS CLEANING SOLVENT HAZARD</p> <p>Many cleaning solvents can degrade plastic parts and cause them to fail, which could cause serious injury or property damage.</p> <ul style="list-style-type: none"> • Use only compatible solvents to clean plastic structural or pressure-containing parts. • See Technical Specifications in all equipment manuals for materials of construction. Consult the solvent manufacturer for information and recommendations about compatibility.
  	<p>PRESSURIZED EQUIPMENT HAZARD</p> <p>Fluid from the equipment, leaks, or ruptured components can splash in the eyes or on skin and cause serious injury.</p> <ul style="list-style-type: none"> • Follow the Pressure Relief Procedure in your pump manual when you stop spraying/dispersing and before cleaning, checking, or servicing equipment. • Tighten all fluid connections before operating the equipment. • Check fluid lines and connections daily. Replace worn or damaged parts immediately.
	<p>PRESSURIZED ALUMINUM PARTS HAZARD</p> <p>Use of fluids that are incompatible with aluminum in pressurized equipment can cause serious chemical reaction and equipment rupture. Failure to follow this warning can result in death, serious injury, or property damage.</p> <ul style="list-style-type: none"> • Do not use 1,1,1-trichloroethane, methylene chloride, other halogenated hydrocarbon solvents or fluids containing such solvents. • Do not use chlorine bleach. • Many other fluids may contain chemicals that can react with aluminum. Contact your material supplier for compatibility.
  	<p>THERMAL EXPANSION HAZARD</p> <p>Fluids subjected to heat in confined spaces, including fluid lines, can create a rapid rise in pressure due to the thermal expansion. Over-pressurization can result in equipment rupture and serious injury.</p> <ul style="list-style-type: none"> • Open a valve to relieve the fluid expansion during heating. • Replace fluid lines proactively at regular intervals based on your operating conditions.

! WARNING

 	<p>ENTANGLEMENT HAZARD Rotating parts can cause serious injury.</p> <ul style="list-style-type: none"> • Keep clear of moving parts. • Do not operate equipment with protective guards or covers removed. • Do not wear loose clothing, jewelry or long hair while operating equipment. • Equipment can start without warning. Before checking, moving, or servicing equipment, follow the Pressure Relief Procedure in your pump manual and disconnect all power sources.
	<p>TOXIC FLUID OR FUMES HAZARD Toxic fluids or fumes can cause serious injury or death if splashed in the eyes or on skin, inhaled, or swallowed.</p> <ul style="list-style-type: none"> • Read Safety Data Sheets (SDSs) to know the specific hazards of the fluids you are using. • Store hazardous fluid in approved containers, and dispose of it according to applicable guidelines.
	<p>BURN HAZARD Equipment surfaces and fluid that is heated can become very hot during operation. To avoid severe burns:</p> <ul style="list-style-type: none"> • Do not touch hot fluid or equipment.
	<p>PERSONAL PROTECTIVE EQUIPMENT Wear appropriate protective equipment when in the work area to help prevent serious injury, including eye injury, hearing loss, inhalation of toxic fumes, and burns. Protective equipment includes but is not limited to:</p> <ul style="list-style-type: none"> • Protective eyewear, and hearing protection. • Respirators, protective clothing, and gloves as recommended by the fluid and solvent manufacturer.
 	<p>MOVING PARTS HAZARD Moving parts can pinch, cut or amputate fingers and other body parts.</p> <ul style="list-style-type: none"> • Keep clear of moving parts. • Do not operate equipment with protective guards or covers removed. • Equipment can start without warning. Before checking, moving, or servicing equipment, follow the Pressure Relief Procedure and disconnect all power sources.

Configuration Matrix

Record the model part number and configuration sequence found on your equipment identification plate (ID) to assist you when ordering replacement parts.

Model Part Number:

Configuration Sequence:

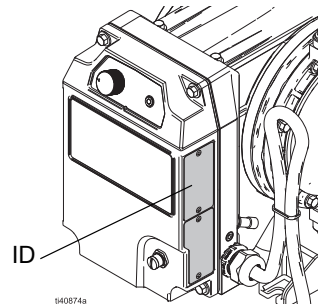

Sample Configuration Sequence: QTC--FC1				
Q	T	C	--	FC1
Brand	Application	Model	--	Motor

NOTE: Some combinations are not possible. Check with your local distributor.

Brand	Application		Model	--		
Q	QUANTM	T	Industrial (i)	C	1 in. port	--
		H	Hygienic (h)	D	1-1/2 in. port	
				E	2 in. port	
				F*	3 in. port	

* Hygienic (QH-) models only.

Motor - Industrial Models						
Drive		Coat	Input Voltage	Phase	Location	Cord/Cable Termination
FC1*	Aluminum Direct Drive	Black powder coat	200-240 V	3-Phase	Industrial, Ordinary Locations	Cord with plug
FC2	Aluminum Direct Drive	Black powder coat	200-240 V	Single-Phase	Industrial, Ordinary Locations	Cord with plug
FC3*	Aluminum Direct Drive	Black powder coat	200-240 V	3-Phase	Industrial, Explosive Atmospheres	Cable with flying leads
FC4	Aluminum Direct Drive	Black powder coat	200-240 V	Single-Phase	Industrial, Explosive Atmospheres	Cable with flying leads
FC5	Aluminum Direct Drive	Black powder coat	100-120 V	Single-Phase	Industrial, Ordinary Locations	Cord with plug
FC6	Aluminum Direct Drive	Black powder coat	100-120 V	Single-Phase	Industrial, Hazardous (Classified) Locations	Cable with flying leads
FE1*	Aluminum Direct Drive	FEP coat	200-240 V	3-Phase	Industrial, Ordinary Locations, Enhanced (Chemical)	Cord with plug
FE2	Aluminum Direct Drive	FEP coat	200-240 V	Single-Phase	Industrial, Ordinary Locations, Enhanced (Chemical)	Cord with plug
FE3*	Aluminum Direct Drive	FEP coat	200-240 V	3-Phase	Industrial, Explosive Atmospheres, Enhanced (Chemical)	Cable with flying leads
FE4	Aluminum Direct Drive	FEP coat	200-240 V	Single-Phase	Industrial, Explosive Atmospheres, Enhanced (Chemical)	Cable with flying leads
FE5	Aluminum Direct Drive	FEP coat	100-120 V	Single-Phase	Industrial, Ordinary Locations, Enhanced (Chemical)	Cord with plug
FE6	Aluminum Direct Drive	FEP coat	100-120 V	Single-Phase	Industrial, Hazardous (Classified) Locations, Enhanced (Chemical)	Cable with flying leads









*Not available with i30 (QTC).









Motor - Hygienic Models						
Drive		Coat	Input Voltage	Phase	Location	Cord/Cable Termination
FF1	Aluminum Direct Drive	Fluorinated ethylene propylene (FEP) coat	200–240 V	3-Phase	Hygienic, Ordinary Locations	Cord with plug
FF2	Aluminum Direct Drive	FEP coat	200–240 V	Single-Phase	Hygienic, Ordinary Locations	Cord with plug
FF3	Aluminum Direct Drive	FEP coat	200–240 V	3-Phase	Hygienic, Hazardous (Classified) Locations	Cable with flying leads
FF4	Aluminum Direct Drive	FEP coat	200–240 V	Single-Phase	Hygienic, Explosive Atmospheres	Cable with flying leads
FF5	Aluminum Direct Drive	FEP coat	100–120 V	Single-Phase	Hygienic, Ordinary Locations	Cord with plug
FF6	Aluminum Direct Drive	FEP coat	100–120 V	Single-Phase	Hygienic, Hazardous (Classified) Locations	Cable with flying leads

Motor Drive Selection			
Industrial - North America			
Model	Ordinary Location (NEMA Plug)	Hazardous Location (Flying Leads)	Voltage range/phase count
i30 (QTC)	FC5	FC6	100/120V/Single-Phase
i80 (QTD)	FC1	FC3	200/240V/3-Phase
i120 (QTE)	FC1	FC3	200/240V/3-Phase
Industrial - International			
Model	Ordinary Location (IEC Plug)	Hazardous Location (Flying Leads)	Voltage range/phase count
i30 (QTC)	FC2	FC4	200/240V/Single-Phase
i80 (QTD)	FC2	FC4	200/240V/Single-Phase
i120 (QTE)	FC2	FC4	200/240V/Single-Phase
Industrial - Enhanced (Chemical) - North America			
Model	Ordinary Location (NEMA Plug)	Hazardous Location (Flying Leads)	Voltage range/phase count
i30 (QTC)	FE5	FE6	100/120V/Single-Phase
i80 (QTD)	FE1	FE3	200/240V/3-Phase
i120 (QTE)	FE1	FE3	200/240V/3-Phase
Industrial - Enhanced (Chemical) - International			
Model	Ordinary Location (IEC Plug)	Hazardous Location (Flying Leads)	Voltage range/phase count
i30 (QTC)	FE2	FE4	200/240V/Single-Phase
i80 (QTD)	FE2	FE4	200/240V/Single-Phase
i120 (QTE)	FE2	FE4	200/240V/Single-Phase

Motor Drive Selection			
Hygienic - North America			
Model	Ordinary Location (NEMA Plug)	Hazardous Location (Flying Leads)	Voltage range/phase count
h30 (QHC)	FF1, FF5	FF3, FF6	200/240V/3-Phase 100/120V/Single-Phase
h80 (QHD)	FF1	FF3	200/240V/3-Phase
h120 (QHE)	FF1	FF3	200/240V/3-Phase
Hygienic - International			
Model	Ordinary Location (IEC Plug)	Hazardous Location (Flying Leads)	Voltage range/phase count
h30 (QHC)	FF2	FF4	200/240V/Single-Phase
h80 (QHD)	FF2	FF4	200/240V/Single-Phase
h120 (QHE)	FF2	FF4	200/240V/Single-Phase

Models and Approvals





Motor Models and Approvals - Industrial				
Location	Approvals	Part	Model	Configuration*
Ordinary Locations	 <p>Complies with UL 1004-1 and CSA C22.2 No. 100:14</p>	25U100 2001058	i30	QTC--FC5 QTC-FE5
		25U101 2001066	i80	QTD--FC1 QTD-FE1
		25U102 2001070	i120	QTE--FC1 QTE-FE1
	 	25U104 2001061	i30	QTC--FC2 QTD-FE2
		25U105 1001067	i80	QTD--FC2 QTD-FE2
		25U106 2001071	i120	QTE--FC2 QTE-FE2
Hazardous (Classified) Locations	 <p>Class I, Division 1, Groups C,D T4 Class 1, Zone 1, Group IIB</p>	25U116 2001063	i30	QTC--FC6 QTC-FE6
		25U117 2001068	i80	QTD--FC3 QTD-FE3
		25U118 2001072	i120	QTE--FC3 QTE-FE3
Explosive Atmospheres	  <p>II 2 G Ex db IIB T4 Gb CML 23 ATEX 1367X IECEX CML 23.0124X</p>  <p>24-KA4BO-XXXXX Applied safety certification standards: Protective device safety certification notice No. 2021-22</p> 	25U120 2001065	i30	QTC--FC4 QTC-FE4
		25U121 2001069	i80	QTD--FC4 QTD-FE4
		25U122 2001073	i120	QTE--FC4 QTE-FE4

Motor Models and Approvals - Hygienic					
Location	Approvals	Part	Model	Configuration*	
Ordinary Locations	 Complies with UL 1004-1 and CSA C22.2 No. 100:14	25U108	h30	QHC--FF5	
		26D767		QHC--FF1	
		25U109	h80	QHD--FF1	
		25U110	h120	QHE--FF1	
	 	25U112	h30	QHC--FF2	
		25U113	h80	QHD--FF2	
		25U114	h120	QHE--FF2	
Hazardous (Classified) Locations	 Class I, Division 1, Groups C,D T4 Class 1, Zone 1, Group IIB	25U124	h30	QHC--FF6	
		26D769		QHC--FF3	
		25U125	h80	QHD--FF3	
		25U126	h120	QHE--FF3	
Explosive Atmospheres	 2575 	25U128	h30	QHC--FF4	
		25U129	h80	QHD--FF4	
		25U130	h120	QHE--FF4	
	 II 2 G Ex db IIB T4 Gb CML 23 ATEX 1367X IECEx CML 23.0124X				
					 24-KA4BO-XXXXX Applied safety certification standards: Protective device safety certification notice No. 2021-22

ATEX T-code rating depends on the temperature of the fluid being dispensed. Fluid temperature is limited by the materials of the equipment interior wetted parts. See **Technical Specifications** for the maximum fluid operating temperature for your specific equipment model.





* See **Configuration Matrix**, starting on page 8, for detailed descriptions.

Repair



				
<p>To avoid injury from fire, explosion, or electric shock, all electrical wiring must be done by a qualified electrician and comply with all local codes and regulations.</p> <p>To prevent electric shock, turn off the equipment and disconnect from power before performing any service or repair procedure.</p> <p>Do not modify or repair explosion proof joints, and use only the specified genuine Graco screws or bolts, torqued according to the instructions. Modifying explosion proof joints or using incorrect parts will invalidate the Explosive Atmospheres or Hazardous (Classified) Locations Certification of the equipment and may produce an explosion hazard.</p>				





Follow the **Pressure Relief Procedure** in your related pump manual whenever you see this symbol. See **Related Manuals**, page 2.

				
<p>This equipment stays pressurized until pressure is manually relieved. To help prevent serious injury from pressurized fluid, such as splashing fluid and moving parts, relieve the pressure when you stop operating and before cleaning, checking, or servicing the equipment. Follow the Pressure Relief Procedure in your related pump manual. See Related Manuals, page 2.</p> <p>Follow Prepare Equipment for Repair, page 14, before performing any service or repair to the equipment.</p>				

Prepare Equipment for Repair

				
<p>To avoid injury from fire, explosion, or electric shock, all electrical wiring must be done by a qualified electrician and comply with all local codes and regulations.</p>				

				
<p>Models in Explosive Atmospheres or Hazardous (Classified) Locations: To avoid injury from fire and explosion, move the equipment to a non-explosive or non-hazardous location before performing any service or repair to the equipment.</p>				

Always complete the following procedure before performing any service or repair to the equipment.

1. Flush the equipment. See your related pump manual. See **Related Manuals**, page 2.
2. Relieve the pressure. Follow the **Pressure Relief Procedure** in your related pump manual. See **Related Manuals**, page 2.
3. Turn off the equipment before performing any service or repair procedure:
 - a. Ensure that the control knob (22) is turned to off (0).
 - b. Ensure that the LED light is on solid red.
4. Disconnect power to the equipment before performing any service or repair procedure. This will turn off the LED light.
5. If connected, disconnect all fluid lines.

6. Optional: Mount the back of the pump (opposite side from the motor) to the maintenance bracket stand (see **Maintenance Bracket Stand**, page 43). This positions the pump facing up, enabling easy working access to the pump and motor. The stand can be mounted to a workbench through the mounting holes on the feet. See FIG. 1.
 - a. Loosen the four bolts that hold the logo plate (if present) to the pump.
 - b. Slide the bracket stand behind the bolts.
 - c. Tighten the bolts.
 - d. Before returning the pump to service, remove it from the bracket stand.

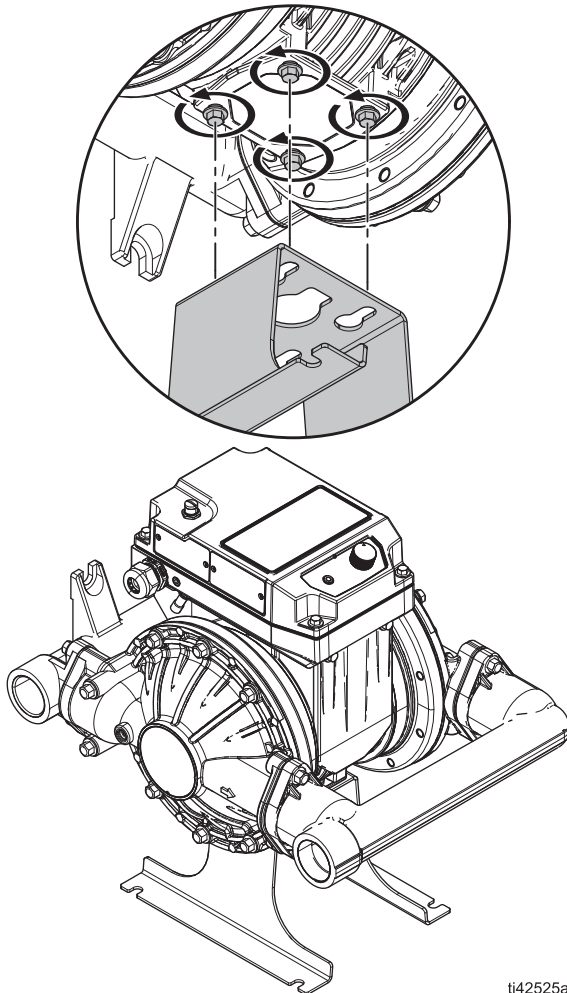

ti42525a

FIG. 1. Maintenance bracket stand

Torque Instructions

To ensure proper sealing, torque fasteners using the following procedure.



1. Start all fasteners a few turns.
2. Tighten each fastener until each fastener is slightly under the torque specified in the instructions.
3. Tighten each fastener by 1/2 turn or less until each fastener is at the specified torque.

Replace the Control Cover

Perform the following procedure when removing or installing the control cover (2).

Required Tools:

- 10 mm socket wrench

				
To avoid injury from electric shock, all electrical wiring must be done by a qualified electrician and comply with all local codes and regulations.				

Remove the Control Cover

1. Follow **Prepare Equipment for Repair**, page 14.
2. Remove the fasteners (3) from the control cover (2).

 Torque to 115 in-lb (13 N•m).

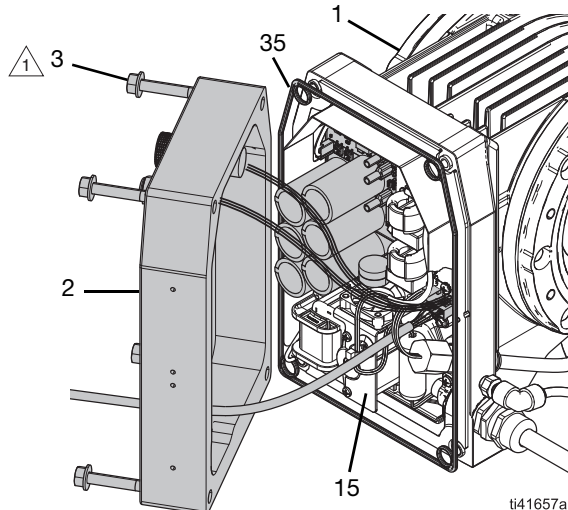

FIG. 2: Control Cover

3. Carefully remove the control cover (2):
 - a. Carefully tilt the control cover (2) away from the control board (15). See FIG. 2.
 - b. Disconnect all wires from the control cover (2) to the control board (15). See **Electrical Schematics**, page 44.

NOTICE

Disconnect all wires before completely removing the control cover. To avoid damage to wires and connections, hold the cover in place at a tilted angle or rest the cover on a work surface while disconnecting wires.

- c. Remove the control cover (2) from the stator housing (1).
4. Inspect for wear or damage. Replace as needed.

Install the Control Cover

1. Verify that power to the equipment is disconnected.
2. Install the gasket (35) into the groove on the stator housing (1).

NOTICE

To avoid damage to the control board, ensure that the gasket (35) is fully seated in the groove and that the control cover (2) is fully pressed to the stator housing (1).

3. Install the control cover (2):
 - a. Carefully hold the control cover (2) in place at an angle near the control board (15). See FIG. 2.
 - b. If a thermal pad is included, verify that it is attached to the cover. If it has fallen off, place it on top of the capacitors before replacing the cover.
 - c. Connect wires from the control cover (2) to the control board (15). See **Electrical Schematics**, page 44.

NOTICE

To avoid damage to wires, connections, control board, or motor, ensure all wires are connected to the correct location. See **Electrical Schematics**, page 44.

- d. Align the control cover (2) to the stator housing (1).
- e. Insert the fasteners (3) into the control cover (2) and tighten. Torque fasteners to 115 in-lb (13 N•m).

NOTICE



To avoid damage to wires or the control board, do not pinch wires when installing the control cover (2) to the stator housing (1).

4. Verify that the control cover (2) contacts the stator housing (1) and the gasket (35) does not show.

Replace the Leak Sensor

Required Tools:

- 7/8 in. open-end wrench
- 3/8 in. hex wrench
- 3/4 in. open-end wrench (for pumps certified for use in Ordinary Locations only)

				
To avoid injury from electric shock, all electrical wiring must be done by a qualified electrician and comply with all local codes and regulations.				

Remove the Leak Sensor

1. Follow **Prepare Equipment for Repair**, page 14.
2. Remove the control cover. See **Remove the Control Cover**, page 16.
3. Disconnect the leak sensor wire (A) from the port in the control housing (S).

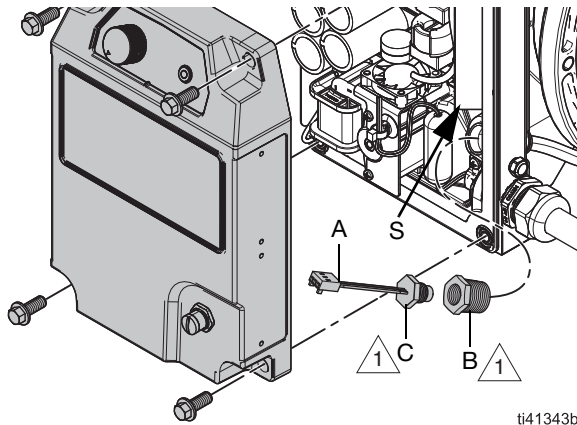

 Apply Loctite 425 Assure thread sealant to the threads.

Fig. 3: Leak Sensor, Pumps Certified for Use in Ordinary Locations



ti41344b

 Apply Loctite 425 Assure thread sealant to the threads.

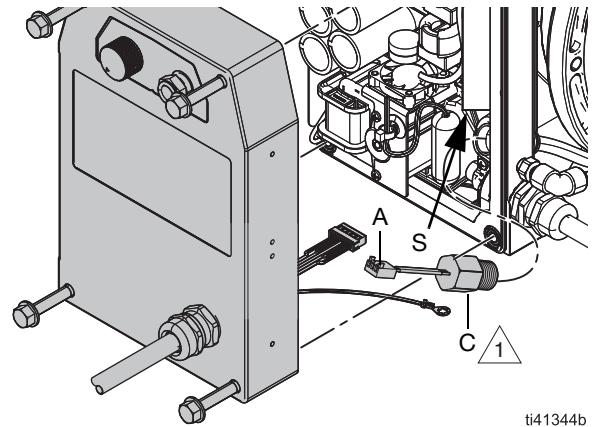
Fig. 4: Leak Sensor, Pumps Certified for Use in Explosive Atmospheres or Hazardous (Classified) Locations

4. **Pumps Certified for Use in Ordinary Locations only:** Loosen the fitting (B) behind the leak sensor (C).

NOTICE

To avoid damage to the control board, ensure that fluid does not contact electrical components in the control housing.

5. Remove the leak sensor (C) assembly and reducer fitting (B, if applicable) from the control housing (S).
6. Ensure there is no fluid in the leak sensor or in the control housing.
7. **Pumps Certified for Use in Ordinary Locations only:** Disconnect the fitting (B) from the leak sensor (C).
8. Disconnect the hoses (F, H, if applicable) and fittings (D, J, if applicable, K, if applicable, N, if applicable) from the pump.
9. Inspect for wear or damage. Replace as necessary.

Install the Leak Sensor

1. Follow **Prepare Equipment for Repair**, page 14.
2. Verify that the bottom switch (SW1) for the leak sensor is in the ON position (left).

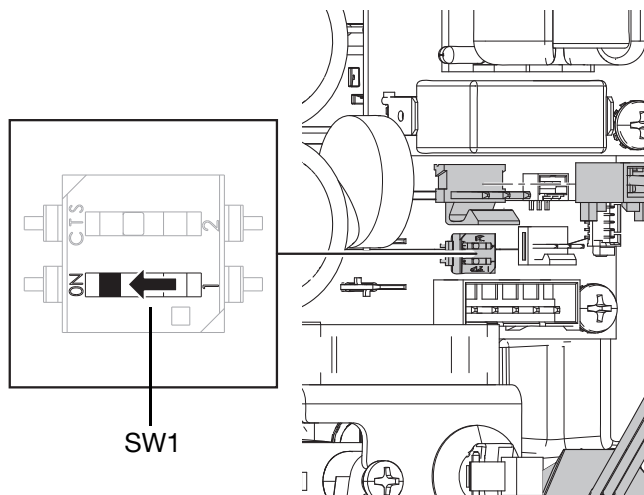

FIG. 5: Leak Sensor Switch in ON position

3. Apply Loctite 425 Assure watertight thread sealant to the threads on the leak sensor (C).
4. **For pumps Certified for Use in Ordinary Locations only:**
 - Install the leak sensor (C) to the reducer fitting (B).
 - Apply Loctite 425 Assure watertight thread sealant to the threads on the reducer fitting (B).
5. Install the leak sensor (C) assembly to the control housing (S).

NOTICE

Ensure that the leak sensor is installed tightly so that fluid cannot enter the control housing. Do not overtighten. Excessive tightening could strip the leak sensor threads.

After reassembly, allow the thread sealant to cure for 12 hours, or per instructions of the manufacturer, prior to operating the system.

6. **Pumps Certified for Use in Ordinary Locations only:** Securely tighten the reducer fitting (B) behind the leak sensor (C).
7. Connect the leak sensor wire (A) to the port in the control housing (S).
8. Ensure the switch for the leak sensor is turned to the ON position.

9. Install the control cover. See **Install the Control Cover**, page 16.
10. Connect the hoses and fittings as applicable to the pump. For instructions, see one of the following sections:

Connect the Hoses and Fittings for Pumps Certified for Use in Ordinary Locations, page 19, or

Connect the Hoses and Fittings for Pumps Certified for Use in Explosive Atmospheres or Hazardous (Classified) Locations, page 20.

Connect the Hoses and Fittings for Pumps Certified for Use in Ordinary Locations

NOTICE

Firmly tighten all connections to avoid leaks and damage to equipment parts.

1. Cut the length of the hose (F) into three segments (F1 and F2). See **Hose Cut Lengths**, page 21.
 - a. Cut one long length of hose for F1.
 - b. Cut two short lengths of hose for F2.

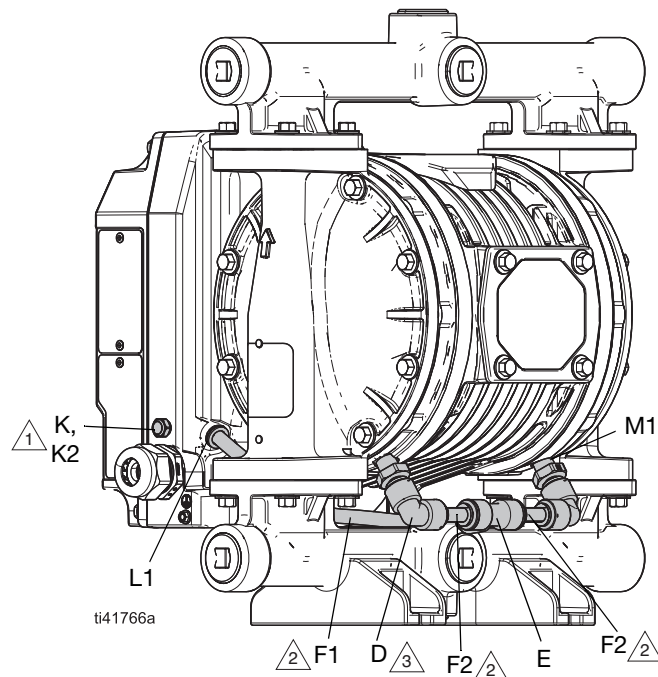

1 Ensure the side port (K2) can breathe.

2 Cut to length.

3 Apply thread sealant to threads.

FIG. 6: Typical Installation for Leak Sensor Hoses and Fittings for Pumps Certified for Use in Ordinary Locations, Industrial Pump Shown

2. Install each elbow fitting (D) into the bottom ports (M1).
3. Apply thread sealant to the threads of the elbow fittings (D).
4. Connect one end of each short length of hose (F2) to an elbow fitting (D).
5. Connect the open end of each short lengths of hose (F2) on each side of the tee union (E).

6. Connect the long length of hose (F1) to the center port of the tee union (E).
7. Connect the open end of the long length of hose (F1) to the quick connect port (L1).
8. Install a breather fitting (K) in the side port (K2).

NOTE: The side port (K2) must be able to breathe for the leak sensor to work properly.
9. Firmly tighten all connections.

NOTICE

To avoid leaks and damage to equipment parts, ensure the hoses are fully seated in the fittings.

Connect the Hoses and Fittings for Pumps Certified for Use in Explosive Atmospheres or Hazardous (Classified) Locations

NOTICE

Firmly tighten all connections to avoid leaks and damage to equipment parts.

1. Cut the length of the hose (F) into three segments (F1 and F2). See **Hose Cut Lengths**, page 21. See FIG. 7 .
 - a. Cut one long length of hose for F1.
 - b. Cut two short lengths of hose for F2.

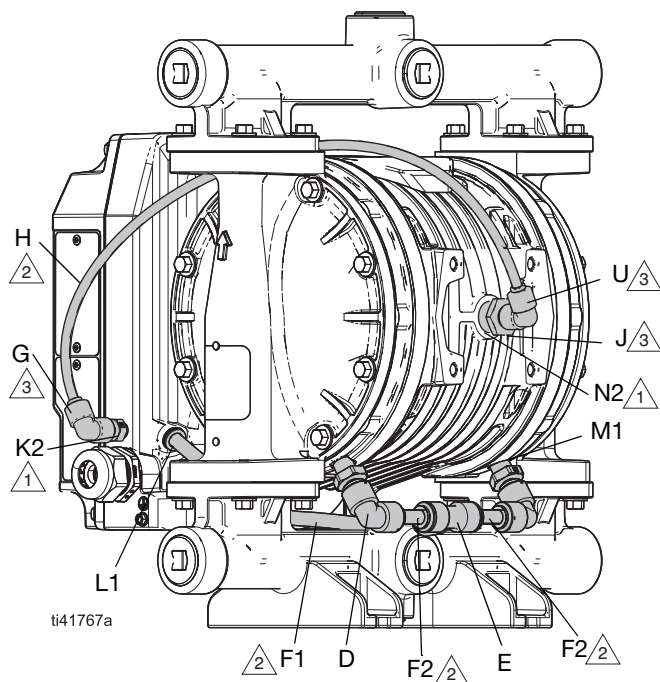

- 1 Ensure the side port (K2) and center section port (N2) are connected and sealed.
- 2 Cut to length.
- 3 Apply thread sealant to threads.

FIG. 7: Typical Installation for Leak Sensor Hoses and Fittings for Pumps Certified for Use in Explosive Atmospheres or Hazardous (Classified) Locations, Industrial Pump Shown

2. Install each elbow fitting (D) into the bottom ports (M1).
3. Apply thread sealant to the threads of the elbow fittings (D).

4. Connect one end of each short length of hose (F2) to an elbow fitting (D).
5. Connect the open end of each short lengths of hose (F2) on each side of the tee union (E).
6. Connect the long length of hose (F1) to the center port of the tee union (E).
7. Connect the open end of the long length of hose (F1) to the quick connect port (L1).
8. Install an elbow fitting (G) in the side port (K2).

NOTE: Apply thread sealant to the threads of the elbow fitting (G).

To avoid injury from fire and explosion, ensure the system is sealed with a connection between the side port (K2) and the center section port (N2).				

9. Connect one end of the hose (H) to the elbow fitting (G).
10. Connect an elbow fitting (U) to the bushing fitting (J).
11. Apply thread sealant to the threads of the bushing fitting (J).
12. Install the bushing fitting (J) assembly to the center section port (N2).
13. Connect the other end of the hose (H) to the elbow fitting (U).
14. Firmly tighten all connections.

NOTICE

Firmly tighten all connections to avoid leaks and damage to equipment parts.

Hose Cut Lengths

Trim the hose length using a perpendicular (square) cut.

1. Cut one long length of hose for F1.
2. Cut two short lengths of hose for F2.

Pump Configuration		Hose (F1)		Hose (F2)		
		in.	cm	in.	cm	
QT (Industrial)	C	8-5/8	21.9	2-1/2	6.35	
	D	9-3/8	23.8	2-1/4	5.72	
	E	9-1/8	23.2	2-1/2	6.35	
QH (Hygienic)	C	Food Grade	11-1/8	28.3	2	5
		Other	12-1/8	30.8	2	5
	D	Food Grade	9-1/4	23.5	2-5/8	6.67
		Other	10	25.4	2-5/8	6.67
	E		9-1/8*	23.2*	2-3/4	7

* Cut lengths may vary. Verify the distance between fittings and cut accordingly.

Test the Leak Sensor

1. Ensure that the pump is properly installed and set up for operation. See your related pump manual. See **Related Manuals**, page 2.
2. Start the pump to verify that the leak sensor is properly working. See your related pump manual.
 - If the leak sensor is not properly installed or working, the LED indicator on the pump will flash or the pump will not start.
 - If a leak is detected by the sensor, the LED indicator on the pump will flash.

Replace the Power Cord/Cable

Repair kits are available (purchase separately). See **Kits and Accessories**, page 41.

Required Tools:

- 1-5/16 in. open-end wrench
- P2 (0.8 mm) Phillips screwdriver

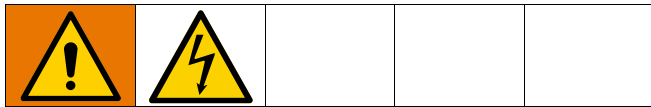

To avoid injury from electric shock, all electrical wiring must be done by a qualified electrician and comply with all local codes and regulations.

Remove the Power Cord/Cable

1. Follow **Prepare Equipment for Repair**, page 14.
2. Follow **Remove the Control Cover**, page 16.
3. Disconnect the power cord/cable wires (38a) from the control board (15).

NOTE: Take note of the orientation of the cord/cable clamp (38b) for installation.

4. Remove the power cord/cable (38) from the cord/cable tie (38c).
5. Loosen the outer strain relief bushing (34a). Do not remove.
6. Remove the cord/cable clamp (38b).
7. Gently pull the power cord/cable (38) and wires out of the stator housing (1).
8. Inspect for wear or damage. Replace as needed. If replacing, remove the ferrite and reinstall on the replacement cord/cable.

Install the Power Cord/Cable

1. Verify that the power cord/cable is not connected to a power source.
2. Reinstall the ferrite that you removed from the power cord/cable that you are replacing.
3. Insert the power cord/cable (38) and wires (38a) through the strain relief bushings (34a, 34) and stator housing (1).
4. Install a cord/cable tie (38c, not supplied).
5. Secure the power cord/cable (38) with the cord/cable tie (38c).

6. Connect power cord/cable wires (38a) to the control board (15). See **Electrical Schematics**, page 44.

NOTICE

To avoid damage to wires or control board, do not strain or kink power cord/cable wires.

7. Tighten the outer strain relief bushing (34a). Securely tighten.
8. Install the cord/cable clamp (38b). Securely tighten the fasteners on the cord/cable clamp (38b).

NOTE: Orient the cord/cable clamp (38b) as originally installed on your equipment model.

9. Follow **Install the Control Cover**, page 16.

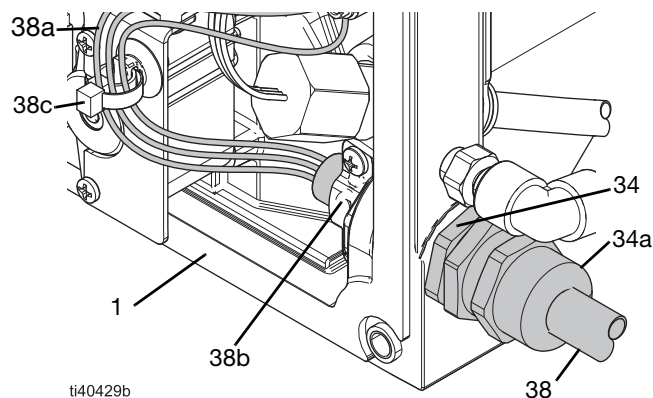

FIG. 8: Power Cord/Cable (F-1, F-3, F-5, and F-6 motors)

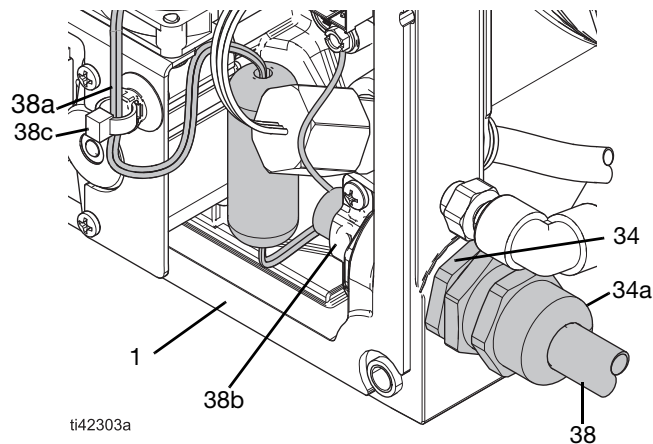

FIG. 9: Power Cord/Cable (F-2 and F-4 motors)



Repair the Fan Assembly

Repair kits are available (purchase separately). See **Kits and Accessories**, page 41.

Required Tools:

- 10 mm socket wrench
- P2 (0.8 mm) Phillips screwdriver
- Thermal paste
- Screw extractor
- Fan press tool*

* Kits are available (purchase separately). See **Kits and Accessories**, page 41.

				
<p>To avoid injury from electric shock, all electrical wiring must be done by a qualified electrician and comply with all local codes and regulations.</p> <p>To avoid injury from moving parts, keep clear of moving parts.</p>				

Remove the Fan Assembly

1. Follow **Prepare Equipment for Repair**, page 14.
2. Remove the fasteners (3) from the fan guard (32).
3. Remove the fan guard (32) from the stator housing (1).
4. Remove the fan propeller (25) from the motor shaft (24d).
5. Follow **Remove the Control Cover**, page 16.
6. Disconnect the fan cable (28b) and motor cable (24c) from the control board (15). See **Electrical Schematics**, page 44.
7. Remove the fasteners (26) from the fan motor (24) assembly.
8. Remove the fan motor (24) assembly from the stator housing (1).
9. Disassemble the fasteners (29), fan (28), mounts (24a, 24b), and fan motor (24).
10. Inspect for wear or damage. Replace as needed.

NOTE: Carefully inspect the motor bearing (23) for wear or damage. Only remove the motor bearing (23) if replacing. If applicable, use a screw extractor to remove the motor bearing (23).

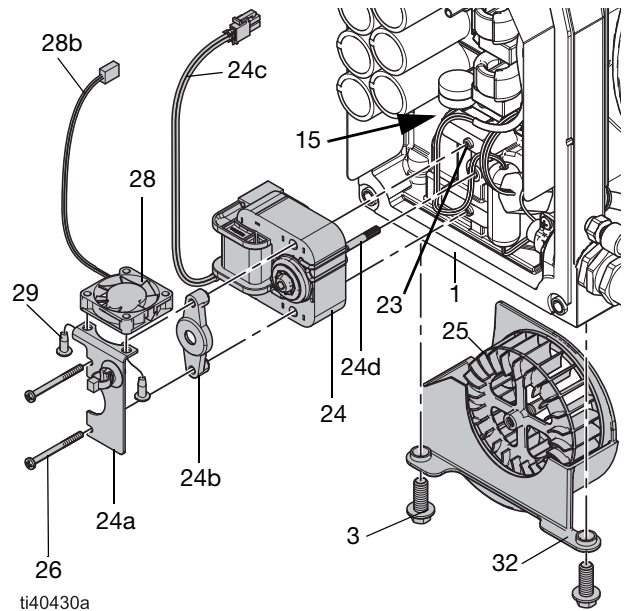

FIG. 10: Fan Assembly

Install the Fan Assembly

1. Verify that power to the equipment is disconnected.
2. Use the fan press tool to install the fan propeller (25) and fan motor (24):
 - a. Separate the press bushing (AA) from the fan holster (BB) on the fan press tool.

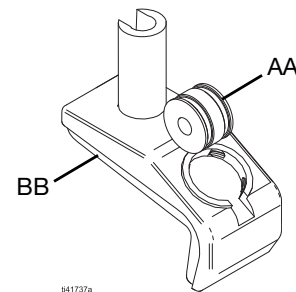

FIG. 11: Fan Press Tool

- b. If the motor bearing (23) was removed: Insert the press bushing (AA) into the motor bearing. Lightly tap on the press bushing (AA) to install the motor bearing (23).

NOTE: The motor bearing (23) will sit slightly raised from the surface of the stator housing (1).

NOTICE

To avoid damage to the motor bearing (23), do not use excessive force when tapping in the motor bearing (23). If needed, use a rubber mallet to tap on the press bushing (AA).

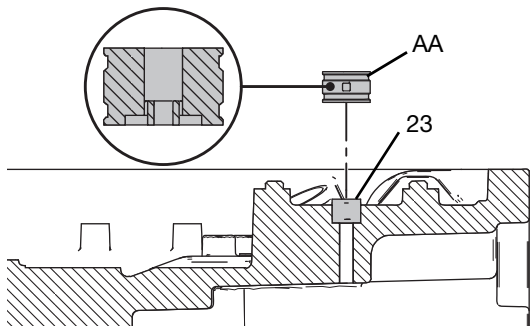

FIG. 12: Press Bushing on Motor Bearing

- c. Insert the fan propeller (25) into the holster (BB).
- d. Insert the fan propeller (25) with holster (BB) into the stator housing (1). Ensure the hole for the fan motor shaft (24d) aligns with the center of the fan propeller (25).
- e. Apply thermal paste to the contact surface between the fan motor (24) and stator housing (1).
- f. Insert the fan rotor (24d) into position on the stator housing (1).

NOTICE

To avoid damage to wires, do not pinch wires when installing the fan motor assembly.

- g. Insert the press bushing (AA) onto the fan motor shaft (24d).
- h. Lightly tap the press bushing (AA) to connect the fan motor shaft (24d) to the fan propeller (25).

NOTICE

To avoid damage to the fan assembly, do not use excessive force when tapping on the motor shaft (24d). If needed, use a rubber mallet to tap on the press bushing (AA).

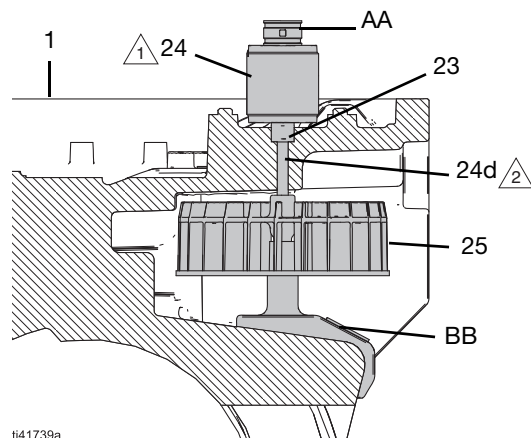

- 1 Apply thermal paste to the contact surface between the fan motor (24) and stator housing (1).
- 2 Ensure that the fan motor shaft is completely pressed in to the fan propeller (25). Ensure that only the smooth part of the shaft is visible.

FIG. 13: Fan and Motor Assembly with Fan Press Tool

- i. Ensure that the fan motor shaft is completely pressed in to the fan propeller (25).
- j. Remove the fan press bushing (AA) and fan holster (BB).
3. Assemble the fan assembly (28), fasteners (29), and mounts (24a, 24b).
4. Apply thread sealant to fasteners (26).
5. Hold the fan (28) assembly in place and install the fasteners (26) through the fan assembly. Torque fasteners (26) to 20 in-lb (2.3 N•m).
6. Connect the fan cable (28b) and fan motor cable (24c) to the control board (15). See **Electrical Schematics**, page 44.

NOTICE

To avoid damage to wires, do not pinch wires. Use the tie provided to hold wires in place and tucked away from pinch points.

7. Install the fan guard (32) around the fan propeller (25).
8. Install the fasteners (3) into the fan guard (32). Securely tighten.
9. Spin the fan propeller (25) by hand to ensure the propeller can fully and easily turn.
10. Follow **Install the Control Cover**, page 16.

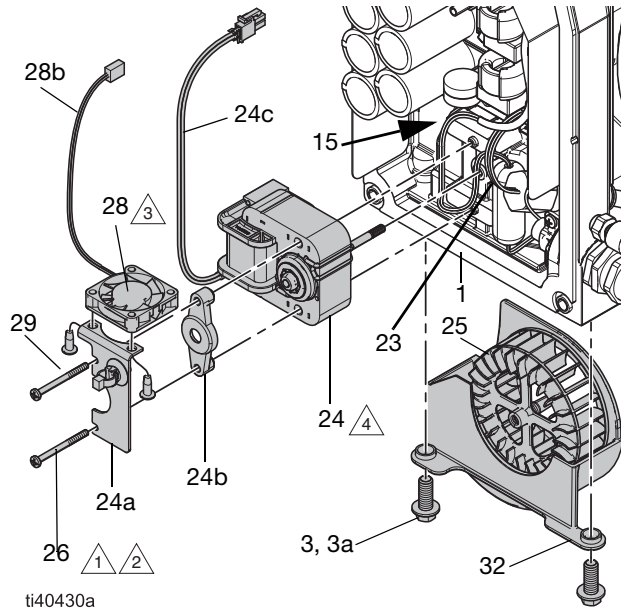

- 1 Apply thread sealant.
- 2 Torque to 20 in-lb (2.3 N•m).
- 3 Ensure the marked arrow on the fan (28) points toward the fan motor (24) and wires are oriented as shown.
- 4 Apply thermal paste to the motor contact parts on the control board (15).

FIG. 14: Reassemble the Fan Assembly

Repair the Control Knob Assembly

Repair kits are available (purchase separately). See **Kits and Accessories**, page 41.

Required Tools:

- 2 mm hex key
- 13 mm open-end wrench
- P2 (0.8 mm) Phillips screwdriver

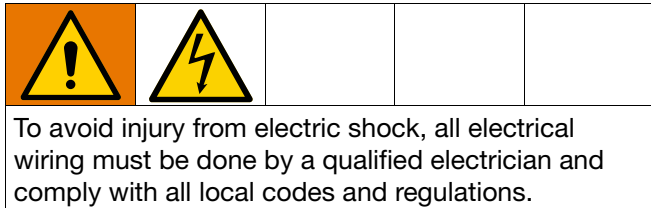

Remove the Control Knob Assembly

1. Follow **Prepare Equipment for Repair**, page 14.
2. Follow **Remove the Control Cover**, page 16.
3. Loosen the control knob fasteners (22a). Remove the control knob (22) and seal (22b).
4. On the back of the control cover (2), remove the fasteners (20a) on the control knob mounting bracket (20).
5. Remove the encoder (21) assembly from the control cover (2).
6. Loosen the push-nut (21a) on the encoder (21) assembly. Remove the control knob mounting bracket (20).
7. Inspect for wear or damage. Replace as needed.

Install the Control Knob Assembly

1. Verify that power to the equipment is disconnected.
2. Prepare the new encoder (21) by verifying that only one nut is installed on the thread of the encoder, and that the nut is screwed down, making contact with the encoder body. If a second nut is present, discard it.
3. Insert the encoder (21) into the control knob mounting bracket (20).
4. Install the push-nut (21a) onto the encoder (21), making contact with the mounting bracket (20).

5. Apply anti-sieze lubricant to the shaft of the encoder (21).
6. Insert the encoder (21) assembly into the control knob hole on the control cover (2).

NOTE: Ensure that the encoder wire (21b) is correctly oriented to easily connect the wire to the control board. See FIG. 15.
7. Insert the fasteners (20a) through the control knob mounting bracket (20).
8. Torque the fasteners (20a) to 20 in-lb (2.3 N•m).
9. Install the seal (22b) on the control knob (22).
10. Install the control knob (22) onto the shaft (21c) on the control cover (2). Ensure the mark on the control knob is aligned with the off (0) position on the control label (40).
11. Securely tighten the control knob fasteners (22a). Ensure the control knob (22) turns properly.
12. Follow **Install the Control Cover**, page 16.

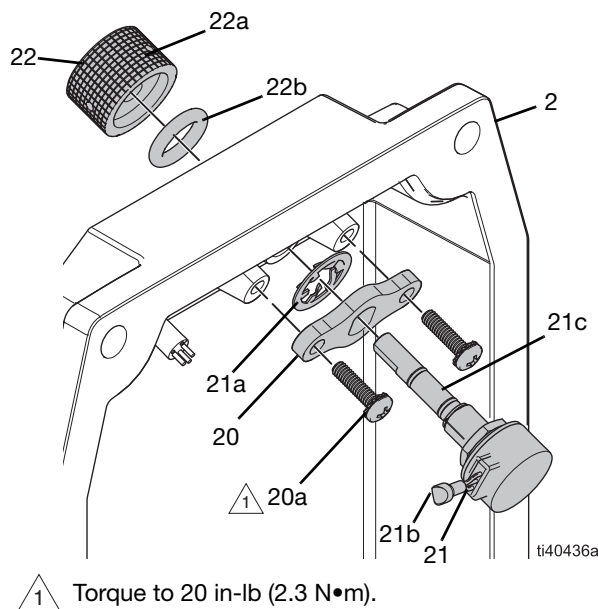

FIG. 15: Control Knob Assembly

Replace the Control Board and Filter Board

Repair kits are available (purchase separately). See **Kits and Accessories**, page 41.

Required Tools:

- P2 (0.8 mm) Phillips screwdriver
- Thermal paste

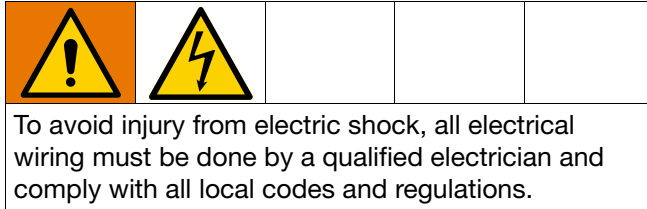

Remove the Control Board and Filter Board Assembly

1. Follow **Prepare Equipment for Repair**, page 14.
2. Follow **Remove the Control Cover**, page 16.
3. Disconnect all wires to the control board (15) and filter board (18, if applicable). See **Electrical Schematics**, page 44.

NOTICE

To avoid damage to wires, connections, or control board, disconnect all wires before removing the control board.

4. If applicable, remove fasteners (19), filter board (18), and spacers (17).
5. Remove the control board fasteners (16).
6. Carefully grip the edges of the control board (15) and gently remove the control board from the stator housing (1).

NOTICE

To avoid damage to the control board, do not pull by components on the control board. Instead, remove the control board by gripping the edges of the control board base.

7. Inspect for wear or damage. Replace as needed.

Install the Control Board and Filter Board Assembly

1. Verify that power to the equipment is disconnected.
2. If needed, apply a thin layer of thermal paste where indicated in FIG. 16.
3. Hold wires away from the stator housing (1) and insert the control board (15) into the stator housing.
4. Hold the control board (15) in place. At the same time, install the control board fasteners (16). Torque to 20 in-lb (2.3 N•m).
5. If applicable, install spacers (17), filter board (18), and fasteners (19). Securely tighten the fasteners (19).
6. If applicable, connect the filter board (18) power brown cable to L1 and blue cable to L2 on the control board. See **Electrical Schematics**, page 44.
7. Connect all wires to the control board (15) and filter board (18, if applicable). See **Electrical Schematics**, page 44.
8. Follow **Install the Control Cover**, page 16.

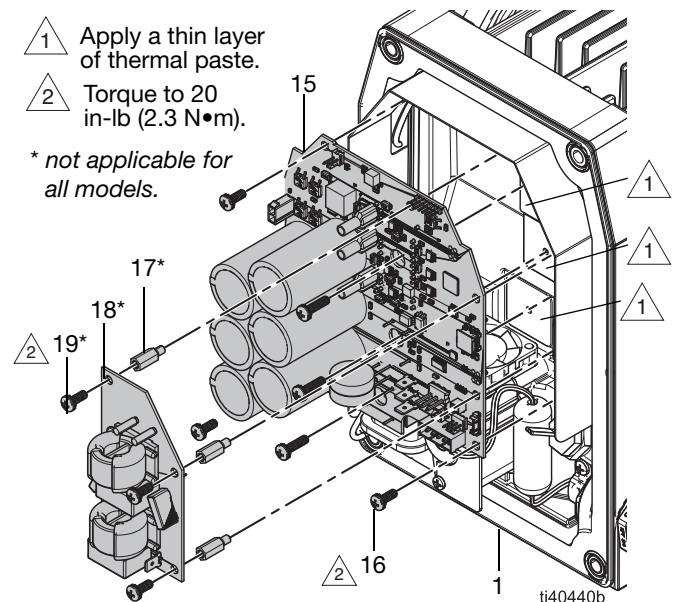

FIG. 16: Control Board and Filter Board

9. Follow **Recalibrate the Motor**, page 34.

Replace the Motor Sensor

Repair kits are available (purchase separately). See **Kits and Accessories**, page 41.

Required Tools:

- 10 mm socket wrench
- T15 Torx screwdriver
- 3 mm hex key wrench
- Dielectric grease



To avoid injury from electric shock, all electrical wiring must be done by a qualified electrician and comply with all local codes and regulations.

Remove the Motor Sensor Board

1. Follow **Prepare Equipment for Repair**, page 14.
2. Remove air side plate with pin (44, 46, if applicable).
3. Remove the fasteners (14) from the sensor-side stator cap (12).
4. Carefully remove the sensor-side stator cap (12) from the stator housing (1).

NOTICE

To avoid damage to the motor sensor or wires, gently remove the sensor-side stator cap (12). Do not jolt the sensor-side stator cap when removing.

5. Disconnect the motor sensor cable (4a) from the motor sensor (4).
6. Remove the fasteners (5) from the motor sensor (4).
7. Remove the motor sensor (4) from the stator housing (1).
8. Inspect for wear or damage. Replace as needed.

Install the Motor Sensor Board

1. Verify that power to the equipment is disconnected.
2. Ensure all surfaces are clean.
3. Apply dielectric grease to the connector on the motor sensor cable (4a).
4. Connect the motor sensor cable (4a) to the motor sensor (4).
5. Align the motor sensor (4) on the stator housing (1), then push the sensor until it clicks into place. Install the fasteners (5) into the motor sensor (4). Torque the fasteners (5) to 20 in-lb (2.3 N•m).
6. Carefully install the sensor-side stator cap (12):
 - a. Align the pin (6) in the stator cap (12) with the pin hole (6a) on the stator housing (1) and gently insert the stator cap (12). Ensure the stator cap is properly set in place.

NOTICE

To avoid damage to the motor sensor or wires, gently insert the sensor-side stator cap (12) into place. Do not jolt the sensor-side stator cap when installing.

- b. Install the fasteners (14) into the sensor-side stator cap (12). Torque to 110 in-lb (12 N•m). See **Torque Instructions**, page 15.

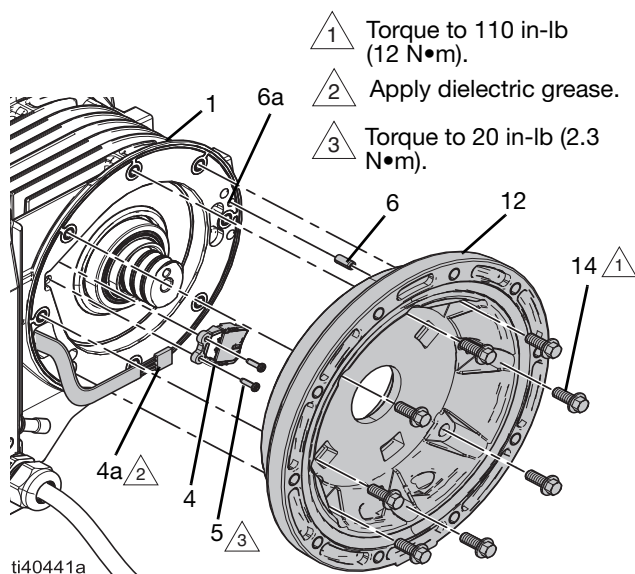

FIG. 17: Motor Sensor

7. Follow **Recalibrate the Motor**, page 34.

Repair the Center Section

Repair kits are available (purchase separately). See **Kits and Accessories**, page 41.

Required Tools:

- 10 mm socket wrench

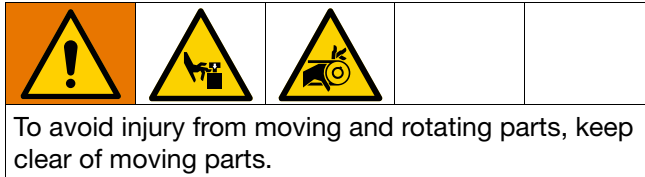

Disassemble the Center Section

1. Follow **Prepare Equipment for Repair**, page 14.
2. Follow **Remove the Rotor**, page 30.
3. Remove the fasteners (14) from the stator caps (12, 13).
4. Remove the stator caps (12, 13).

NOTICE

To avoid damage to the motor sensor or wires, gently remove the sensor-side stator cap (12). Do not jolt the sensor-side stator cap when removing.

5. Remove the seals (11, 47) from the stator caps (12, 13). When you remove the seal (47), you will also remove the hub (8).
6. Inspect for wear or damage. Replace as needed.

Reassemble the Center Section

1. Verify that power to the equipment is disconnected.
2. Carefully install the sensor-side stator cap (12):
 - a. Install the seal (11) in the stator cap (12).
 - b. Align the pin (6) in the stator cap (12) with the pin hole (6a) on the stator housing (1) and gently insert the stator cap (12). Ensure the stator cap is properly set in place. See FIG. 17.

NOTICE

To avoid damage to the motor sensor or wires, gently insert the sensor-side stator cap (12) into place. Do not jolt the sensor-side stator cap when installing.

- c. Install the fasteners (14) into the sensor-side stator cap (12). Torque to 110 in-lb (12 N•m). See **Torque Instructions**, page 15.
3. Follow **Install the Rotor**, page 30.

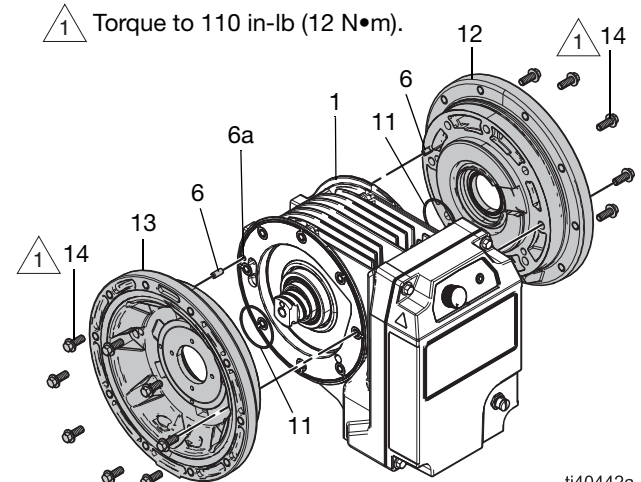

ti40442a

FIG. 18: Center Section, Load-side

Repair the Rotor and Shaft Assembly

See FIG. 17 and FIG. 19.

Required Tools:

- Preload nut installation tools*
- Rotor greasing tool*
- 1 in. (25 mm) open-end wrench
- 1/2 in. square drive socket wrench extension

* Kits are available (purchase separately). See **Kits and Accessories**, starting on page 41.

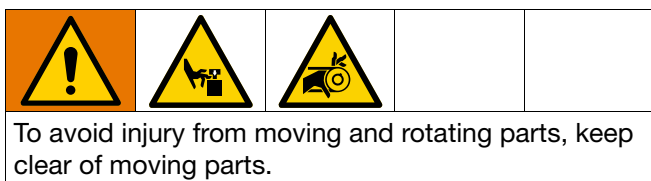

Remove the Rotor

1. Follow **Prepare Equipment for Repair**, page 14.
2. Remove the air side plate with pin (44) on both sides of the equipment.
3. Use the preload nut installation tools and an applicable wrench to remove the preload nut (9) and hub (8) from the load-side stator cap (13).
4. Remove the load-side stator cap (13).

NOTICE

To avoid damage to the motor sensor, do not remove components from the side with sensor-side stator cap (12). Only remove components from the side with the load-side stator cap (13).

5. On the sensor-side, turn the shaft (7a) until it protrudes from the load-side stator cap (12).

NOTICE

To avoid damage to the rotor or equipment, do not remove the shaft (7a) from the rotor (7). Removing the shaft will cause the rotor balls to dislodge from the rotor and the rotor will not function properly.

6. Use an applicable wrench to firmly hold the flat of the shaft (7a) in place. Ensure that the rotor and shaft assembly (7, 7a) does not rotate. At the same time, on the sensor-side, carefully tap the shaft to disengage the rotor and shaft assembly (7, 7a) from the stator housing (1). Tap until the rotor and shaft

assembly emerge from the load-side stator cap (13).

NOTICE

To avoid damage to the shaft or rotor, do not use excessive force when tapping out the rotor and shaft assembly (7, 7a). If needed, use a rubber mallet to disengage the rotor and shaft assembly.

7. Remove the rotor and shaft assembly (7, 7a) from the stator housing (1).
8. Remove the seals (11) from the stator caps (12, 13).

NOTE: Do not remove the shaft (7a) from the rotor (7).

NOTICE

To avoid damage to the rotor or equipment, do not remove the shaft (7a) from the rotor (7). Removing the shaft will cause the rotor balls to dislodge from the rotor and the rotor will not function properly. If the rotor balls dislodge, follow **Re-Ball the Rotor**, page 32.

9. Remove the seal (47) from the hub (8).
10. Inspect for wear or damage. Replace as needed.

Install the Rotor

1. Verify that power to the equipment is disconnected.
2. Reach inside the stator housing (1) to install one seal (11) onto the stator cap (12).
3. Insert the rotor and shaft assembly (7, 7a) into the stator housing (1).

NOTE: Grease the tapered rotor bearings before inserting into the stator housing.

NOTE: Ensure the flat of the shaft (7a) faces toward the load-side stator cap (13).

NOTE: The outer-ring lip of the rotor (7) will sit slightly raised from the stator housing (1).

4. Install the seal (47) on the hub (8).
5. Assemble the other seal (11) to the hub (8).

6. Install the preload nut and hub (9, 8) on the load-side cap (13):
 - a. Apply anti-sieze to the threads of the hub (8).
 - b. Thread the preload hub (8) onto the load-side stator cap (13). Ensure the lips of the preload hub (8) face toward the center of the rotor (7).
 - c. Spin the hub (8) until the seal (47) touches the bore of the cap (13).
 - d. Install the load-side stator cap (13) onto the stator housing (1). First, install the seal (11) in the stator cap (13). See FIG. 18.
 - e. Align the pin (6) in the stator cap (13) with the pin hole (6a) on the stator housing (1) and gently insert the stator cap (13). Ensure the stator cap is properly set in place. See FIG. 18.
 - f. Install the fasteners (14) into the stator cap (13). Torque to 110 in-lb (12N•m). See **Torque Instructions**, page 15.
 - g. Insert the preload hub installation tool into the preload hub (8).
 - h. Use an applicable wrench on the preload hub installation tool to torque the preload hub (8) to 20 ft-lb (27 N•m).
 - i. Remove the preload hub installation tool, and temporarily install an M12 washer and an M12 bolt into the rotor.

NOTE: Washer and bolt are provided in Rotor Replacement kits. If re-using the existing rotor, use a washer with outside diameter 45mm (1.75 inches).
 - j. Use an applicable wrench on the M12 bolt to manually spin the rotor at least ten revolutions to ensure the bearings have been seated correctly, and that the rotor spins within the stator.
 - k. Remove the temporary M12 washer and M12 bolt from the rotor. Discard or keep for future rotor installations.
 - l. Loosen the preload hub (8) by one quarter rotation, then re-torque to 10 ft-lb (13 N•m).

NOTE: To ensure the rotor can properly spin, be careful to not overtighten the preload hub (8).
 - m. Using a marker, mark the location of the hub (8) relative to the stator cap (13).

NOTICE

To avoid equipment damage, do not overtighten the preload hub (8).

- n. Install the preload nut (9).
- o. Use an applicable wrench on the preload nut installation tool to torque the nut (9) to 50 ft-lb (68 N•m).

NOTE: Use an applicable wrench to hold the hub (8) in place. Ensure that the hub (8) does not rotate while torquing the nut (9).

NOTICE

To avoid equipment damage, ensure that the hub (8) does not rotate while torquing the nut (9).

- p. Remove the preload nut installation tool.
 - q. Verify that the hub (8) did not rotate from the marked location relative to the stator cap (13).
7. Lubricate the rotor (7) and shaft (7a). See **Lubricate the Rotor and Shaft**, page 33.

NOTICE

To avoid equipment damage, liberally apply grease on the shaft (7a).

8. Follow **Recalibrate the Motor**, page 34.

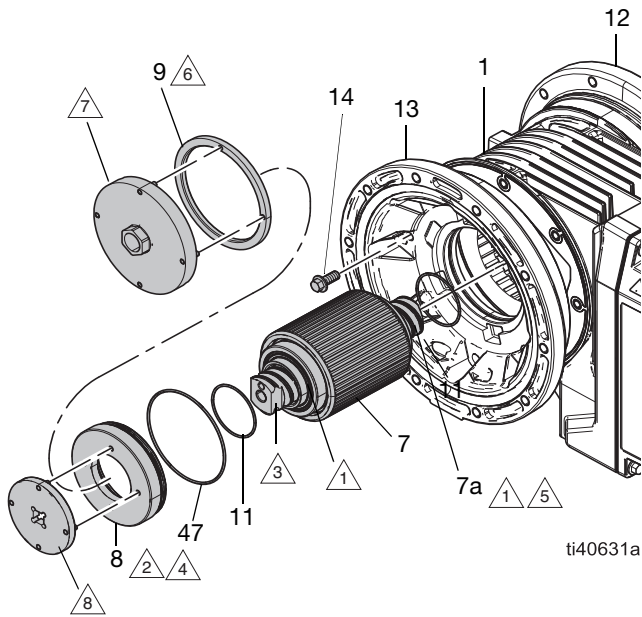

- 1 Grease.
- 2 Lips must face toward center housing (1).
- 3 Face shaft flat opposite the sensor-side stator cap (12).
- 4 Torque to 20 ft-lb (27 N•m). Spin the rotor at least ten revolutions. Loosen the preload hub by one quarter rotation, then re-torque to 9 ft-lb (12 N•m).
- 5 Do not remove the shaft (7a) from the rotor (7).
- 6 Torque to 50 ft-lb (68 N•m).
- 7 Preload Nut Installation Tool, included in kit 25V370.
- 8 Preload Nut Installation Tool, included in kit 25V370.

FIG. 19: Rotor and Shaft Assembly, Load-side

Re-Ball the Rotor

Required Tools:

- Magnet with scribe

NOTICE

If the shaft (7a) was removed from the rotor (7), the rotor balls will dislodge from the rotor and the rotor will not function properly. To avoid damage to the equipment, re-ball the rotor.

1. Follow **Remove the Rotor**, page 30.
2. Prepare a container to catch the loose rotor balls.
3. Rotate the shaft (7a) out of the rotor assembly (7) to remove the rotor balls.

NOTE: Ensure that all rotor balls are removed from the shaft and rotor assembly (7, 7a). Check inside the rotor (7) for any remaining rotor balls.

4. Clean the grease from the shaft (7a) and the rotor assembly (7).
5. Prepare the shaft (7a) for assembly:
 - a. Secure the shaft (7a) in place.
 - b. On the opposite side of the wrench flat, thread a fastener (7b, size M12) into the bolt hole of the shaft (7a).
 - c. Insert the dowel pin (46, if applicable).

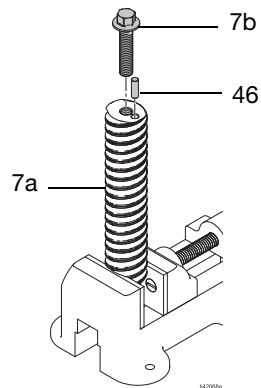

FIG. 20: Prepare the Shaft (7a) for Assembly

6. Install the rotor (7) onto the secured shaft (7a).

NOTE: Thread the rotor assembly (7) onto the shaft (7a) until the thread lead-in is level with the ball nut recirculator.

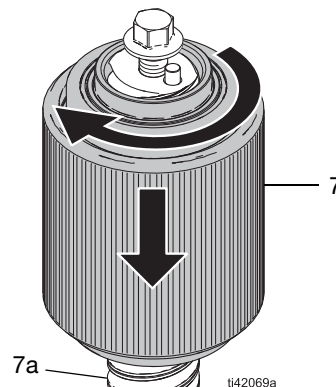

FIG. 21: Assemble the Shaft and Rotor

7. Carefully insert the rotor balls into the rotor (7).
8. Use a magnet and scribe to lead the rotor balls into the shaft (7a).

9. Rotate the rotor (7) up and down the shaft (7a) to set the rotor balls into the shaft threads.
10. Follow **Install the Rotor**, page 30.

Lubricate the Rotor and Shaft

Use the rotor greasing tool to liberally apply grease to the rotor (7) and shaft (7a). See FIG. 22–FIG. 24.

Required Tools:

- Rotor greasing tool*
- Lubriplate Synxtreme HD-2 grease (part number 18F990) or equivalent NLGI Grade 2 synthetic grease with calcium sulfonate base

* Kits are available (purchase separately). See **Kits and Accessories**, starting on page 41.

1. Follow **Prepare Equipment for Repair**, page 14.
2. Remove the collar on the rotor greasing tool (7c).
3. On the load-side, use an applicable wrench to firmly hold the flat of the shaft (7a) in place. Ensure that the rotor and shaft assembly (7, 7a) does not rotate. At the same time, on the sensor-side, thread the rotor greasing tool (7c) into the shaft (7a) until fully joined.

NOTICE

To avoid equipment damage, do not rotate the shaft (7a) while threading the rotor greasing tool (7c) into the shaft. Only turn the rotor greasing tool (7c).

4. Turn the rotor greasing tool into the center of the rotor (7) until the shaft (7a) fully protrudes from the load-side stator cap (13). See FIG. 23.
5. Clean and inspect the shaft (7a) for wear or damage. Replace as needed.
6. Use the grease port (7d) on the rotor greasing tool (7c) to fill the shaft area with clean grease. Fill until clean grease emerges from the edges of the rotor greasing tool (7c).

NOTICE

To avoid equipment damage, liberally apply grease on the shaft (7a).

7. Turn the shaft (7a) to reinsert the shaft into the rotor (7). Turn until the rotor greasing tool (7c) fully emerges from the sensor-side stator cap (12). See FIG. 24.

NOTE: Do not disconnect the shaft from the rotor greasing tool when reinserting the shaft into the rotor. Do not use the rotor greasing tool to turn the shaft into the rotor. Only turn the shaft (7a).

NOTICE

To avoid equipment damage, do not rotate the rotor greasing tool (7c) to reinsert the shaft into the rotor. Only turn the shaft (7a).

8. Use an applicable wrench to firmly hold the flat of the shaft (7a) in place. At the same time, disconnect the rotor greasing tool from the shaft (7a).
9. Clean the internal threads on the shaft (7a) to remove excess grease.

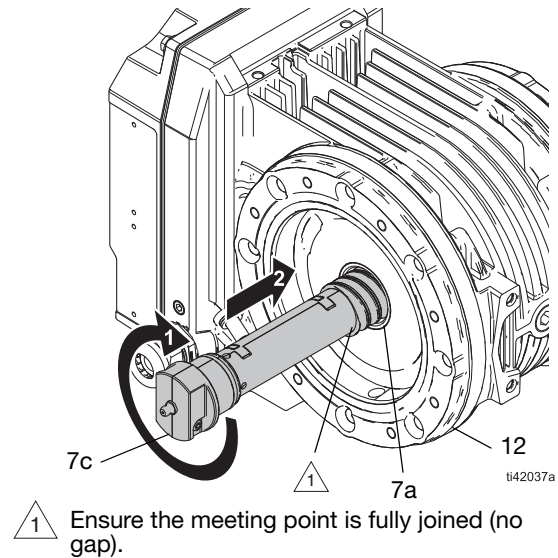

FIG. 22: Insert Rotor Greasing Tool

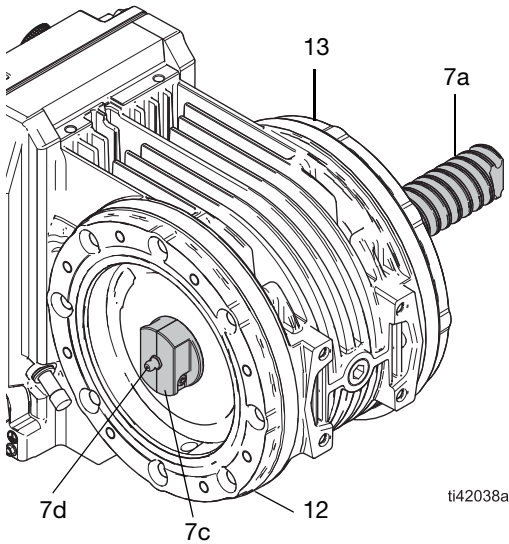

FIG. 23: Rotor Greasing Tool

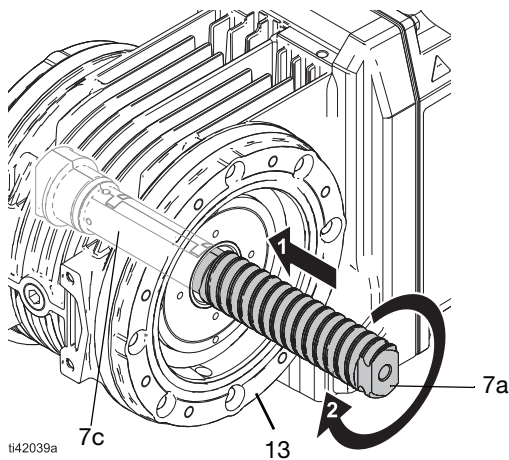

FIG. 24: Remove Rotor Greasing Tool

Recalibrate the Motor

For motor modules Series B or later, recalibrate the motor after installing a new control board, motor sensor, rotor, or re-torquing the preload hub and nut. Recalibrate after you reassemble the motor module but before you install the diaphragms or fluid section.

The motor module series is identified in the serial number on the lower product tag on the side of the

motor module. The motor module series is identified by the fifth character from the right in the serial number.

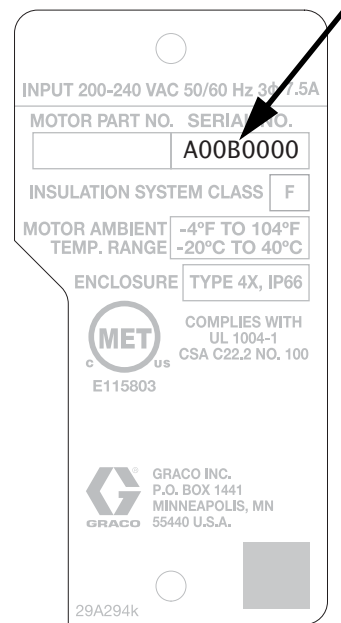

FIG. 25: Motor module serial number location

1. Turn the control knob (22) fully counter-clockwise (off).
2. Power up the motor module.
3. Turn the control knob (22) clockwise (on) to approximately 50% or higher.

The rotor (7) begins to spin. The LED (37) turns yellow.

4. Wait for approximately 20 revolutions (10 seconds).

The rotor (7) momentarily stops. Then it slowly spins one revolution and stops. Then it reverses direction and slowly spins one revolution.

- If the calibration was successful, the rotor (7) begins to spin and the LED (37) turns yellow.
 - If the calibration was unsuccessful, the rotor (7) stops spinning and the LED (37) flashes an error code (seven blinks). Ensure that the rotor is not being restricted during calibration and is free to spin, then repeat this procedure.
5. Turn the control knob (22) fully counter-clockwise (off), and remove power.
 6. Install the diaphragms and finish reassembling the pump.

Recycling and Disposal

At the end of the useful life of the equipment, disassemble and recycle the equipment in a responsible manner.

- Relieve the pressure. Follow the **Pressure Relief Procedure** in your related pump manual. See **Related Manuals**, page 2.
- Drain and dispose of fluids according to applicable regulations. See the Safety Data Sheet (SDS) of the material manufacturer.
- Remove motors, circuit boards, LCDs (liquid crystal displays), and other electronic components. Recycle according to applicable regulations.
- Do not dispose of electronic components with household or commercial waste.



- Deliver remaining equipment to a recycling facility.

Parts

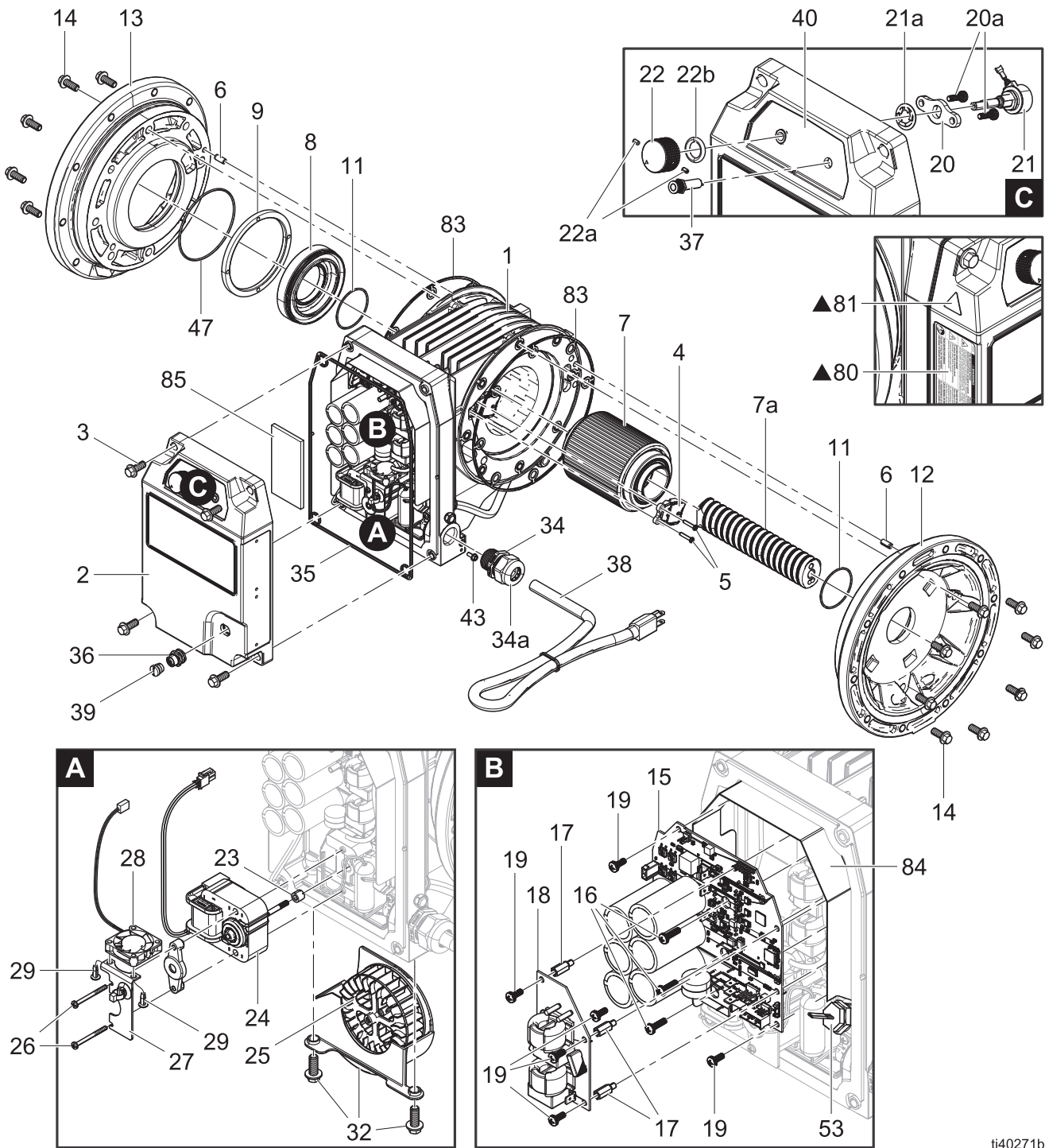
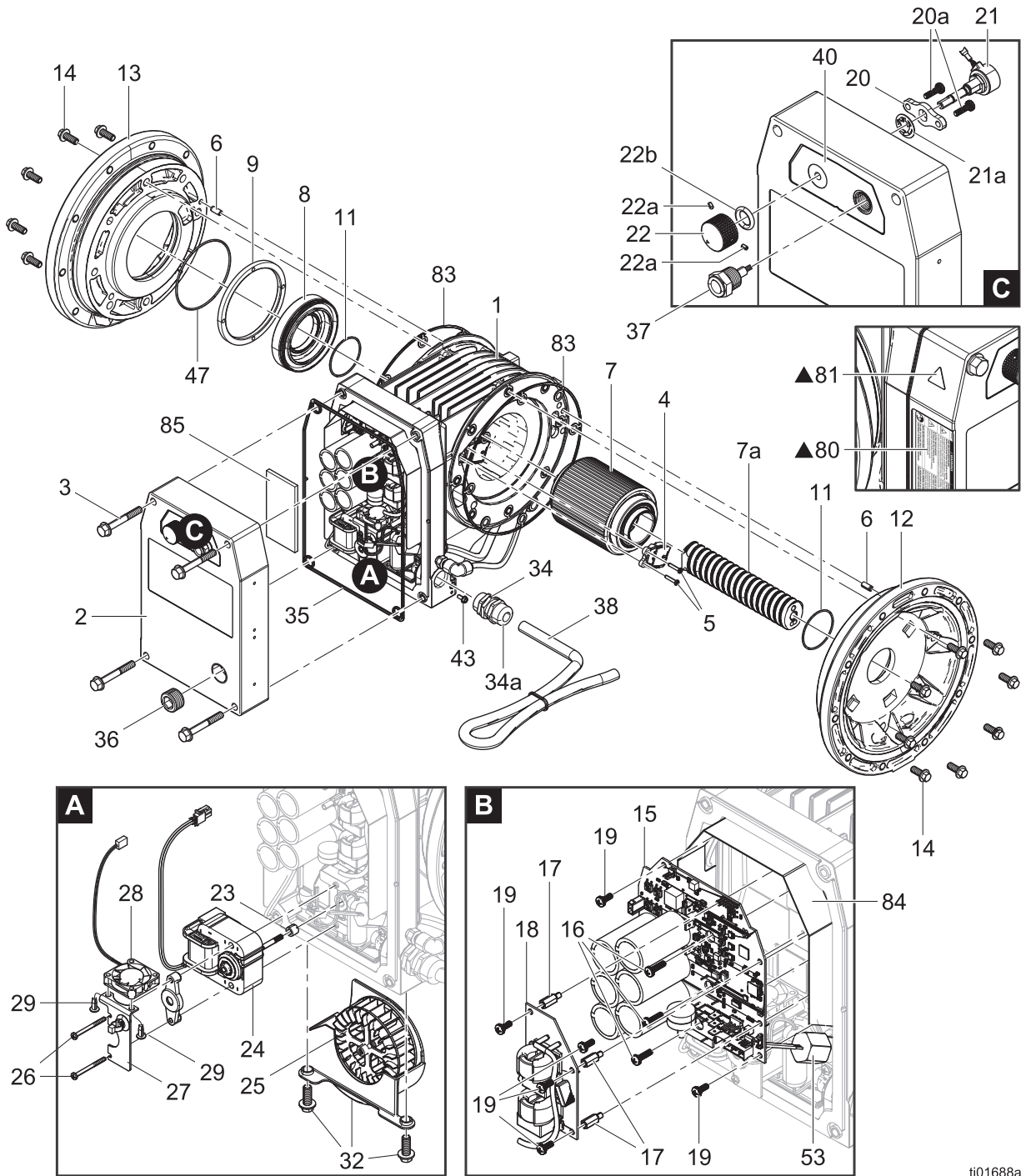

FIG. 26: Motor Module, Ordinary Locations

ti40271b



ti01688a

FIG. 27: Motor Module, Explosive Atmospheres or Hazardous (Classified) Locations

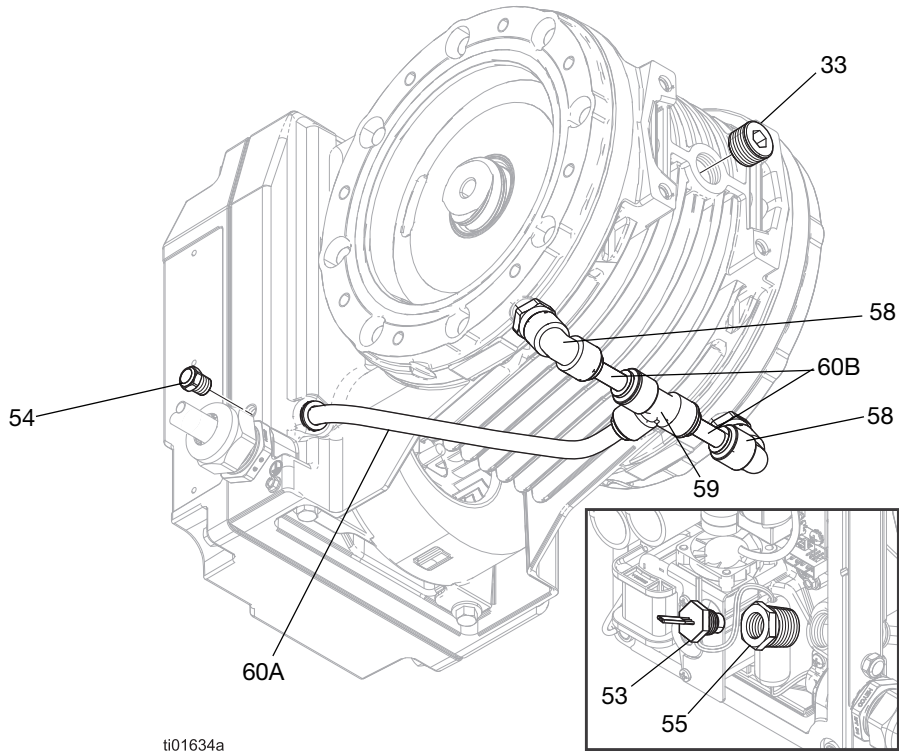

FIG. 28: Leak Sensor, Ordinary Locations

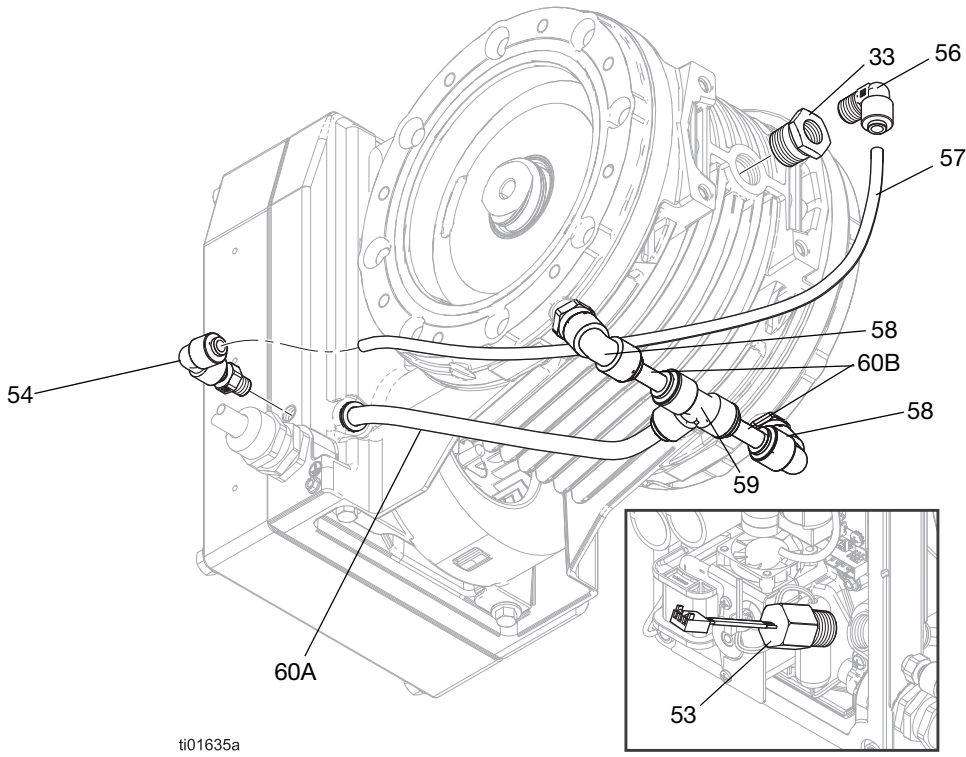

FIG. 29: Leak Sensor, Explosive Atmospheres or Hazardous (Classified) Locations

Parts List

See FIG. 26–FIG. 29.

Ref.	Part	Description	Qty.
1	___‡	STATOR	1
2		COVER, control	1
	25V123	for Industrial (QT) models in Ordinary Locations	
	25V124	for Hygienic (QH) models in Ordinary Locations	
	25V125	for Industrial (QT) models in Explosive Atmospheres or Hazardous (Classified) Locations	
	25V126	for Hygienic (QH) models in Explosive Atmospheres or Hazardous (Classified) Locations	
3	19C157	SCREW, hex washer, M8 x 20; for i30 (QTC), i80 (QTD), i120 (QTE) Ordinary Location	4
	19F961	SCREW, hex head washer, M8 x 60,CS; for i30 (QTC), i80 (QTD), i120 (QTE) Hazardous (Classified) Location	4
	15Y149	BOLT, hex head, M8 x 1.25 x 20 mm; for h30 (QHC), h80 (QHD), h120 (QHE) Ordinary Location	4
	19F897	SCREW, hex wash, M8 x 60, SST, patch; for h30 (QHC), h80 (QHD), h120 (QHE) Hazardous (Classified) Location	4
	115643	SCREW, hex washer, M8 x 25; for i30 (QTC) Ordinary Location i80 (QTD) Ordinary Location i120 (QTE) Ordinary Location	4
	112178	BOLT, hex head, M8 x 1.25 x 25 mm; for h30 (QHC) Ordinary Location h80 (QHD) Ordinary Location h120 (QHE) Ordinary Location	4
4	___‡	SENSOR, motor, assembly	1
5	18G070	FASTENER, self-tapping, 6-19 x 0.75 in. stainless steel	2
6	18A535	PIN, straight slotted spring, 1/4 in. x 9/16 in.	2
7	___‡	ROTOR, assembly	1
7a	___‡	SHAFT, ball screw	1
8	25V127	HUB, preload alignment (with bearing race)	1
9	25V128	NUT, preload	1

Ref.	Part	Description	Qty.
11	___‡	SEAL	2
12	___‡	CAP, stator, sensor-side (with bearing race)	1
13	___‡	CAP, stator, load-side	1
14	19C157	SCREW, hex washer, M8 x 20; for i30 (QTC) Ordinary Location and Hazardous (Classified) Location, i80 (QTD) Ordinary Location and Hazardous (Classified) Location, i120 (QTE) Ordinary Location and Hazardous (Classified) Location	16
	19C158	SCREW, FHS, M8 x 16, SST; for h30 (QHC) Ordinary Location and Hazardous (Classified) Location	16
	15Y149	BOLT, hex head, M8 x 1.25 x 20 mm; for h30 (QHC), h80 (QHD) Ordinary Location and Hazardous (Classified) Location, h120 (QHE) Ordinary Location and Hazardous (Classified) Location	16
15	___‡	BOARD, control assembly, motor drive	1
16	18A538	FASTENER, pan head, M8-32 x 9/16 in.	3
17	16G799	SPACER, standoff, M8-32 x 0.5 in.; FC2, FC4, FE2, FE4, FF2, FF4 models	3
18	___‡	BOARD, assembly, line filter; FC2, FC4, FE2, FE4, FF2, FF4 models	1
19	19C206	FASTENER pan head, external tooth lock washer, M8-32 x 7/16 in.	6
20	___‡	BRACKET, control knob	1
20a	___‡	FASTENER, pan head, control knob bracket	2
21	___‡	ENCODER, control	1
21a	___‡	NUT, push	1
22	___‡	KNOB, control	1
22a	___‡	FASTENER, hex head	2
22b	___‡	SEAL, packing	1
23	___‡*	BEARING, sleeve; <i>not shown</i>	1
24	___‡	MOTOR, fan	1
25	___‡	FAN, propeller	1
26	18F382	FASTENER, pan head, M6-32 x 1-1/2 in.	2
27	---	BRACKET, fan, 40 x 40 mm	1

Parts

Ref.	Part	Description	Qty.
28	25V135	FAN, DC, 40 x 40 x 10 mm; includes 27, 29	1
29	---	SCREW	2
32	25V136	GUARD, fan, squirrel cage	1
33	103778	PLUG, 1/2 in. npt(f); for models in Ordinary Locations; stainless steel	1
	114475	BUSHING, pipe, 1/2 in. NPT x 1/4 in. NPT; for models in Explosive Atmospheres or Hazardous (Classified) Locations; stainless steel	1
34		BUSHING, strain relief	1
	19B642	for models in Explosive Atmospheres (i30, i80, i120)	
	19D671	for models in Explosive Atmospheres (h30, h80, h120)	
	---‡	for models in Hazardous (Classified) Locations	
	20A460	for models in Ordinary Locations	
34a	---	BUSHING, outer strain relief; <i>included with Ref. 34</i>	1
35	20B302	GASKET, control cover	1
36		CONNECTOR or PLUG	1
	20B403	PLUG, 3/4-NPT; for models in Explosive Atmospheres or Hazardous (Classified) Locations	
	19B637	CONNECTOR, I/O M12 cable assembly; for models in Ordinary Locations	
37		HARNESS, wiring with light, LED indicator	1
	19B643	for models in Explosive Atmospheres or Hazardous (Classified) Locations	
	19B939	for models in Ordinary Locations	
38	---‡	CORD/CABLE, power	1
39		PLUG, screw, M12	
	---*	for models in Explosive Atmospheres or Hazardous (Classified) Locations	0
	17C443	for models in Ordinary Locations	1
40		LABEL, EODD control	1
	19C039	for models in Explosive Atmospheres or Hazardous (Classified) Locations	
	19C095	for models in Ordinary Locations	
41	19B616*	CLAMP, cable; <i>not shown</i>	1
41a	112380*	SCREW, <i>not shown</i>	2
43	111593	FASTENER, grounding	2
47	---‡	SEAL, packing	2

Ref.	Part	Description	Qty.
53	---	SENSOR, leak	1
54	---†	BREATHER	1
	---**	FITTING, elbow swivel, 1/8 in. NPT	1
55	---†	FITTING, reducer	1
56	---**	FITTING, elbow, 1/4 in. NPT; 1/4 in. hose port	1
57	---**	HOSE, 1/4 in. outer diameter	1
58	---	FITTING, elbow swivel, 1/4 in. NPT; 3/8 in. hose port	2
59	---	UNION, tee	1
60	---	HOSE, 3/8 in. outer diameter	1
80▲	17K859	LABEL, safety	1
81▲	20A345	LABEL, safety, warning	1
83	---‡	GASKET, stator	2
84	2000158	SHIELD, wire	1
85		PAD, thermal	
	---	for models in North America, Ordinary Locations	0
	---	for i80 and i120 models in EU, Ordinary Locations	2
	---	for models in Hazardous (Classified) Locations	0
	---	for models in Explosive Atmospheres	1

▲ Replacement safety labels, tags, and cards are available at no cost.

--- Not available separately.

* Part not shown in parts diagram.

‡ See **Kits and Accessories**, starting on page 41.

† Ordinary locations only.

** Hazardous locations only.

Kits and Accessories

Part Kits

Part kits are available (purchase separately).

Complete Rotor Repair Kits

Model	Kit No.	Kits include
i30 (QTC)	2002420	<ul style="list-style-type: none"> 1 rotor (7) 1 stator cap (12, 6) 1 preload hub (8) 2 rotor o-rings (11) 1 hub o-ring (47) 4 seat o-rings 2 diaphragm o-rings 1 anti-seize
i80 (QTD)	2002383	
i120 (QTE)	2002384	
h30 (QHC)	2002421	
h80 (QHD)	2002422	
h120 (QHE)	2002423	

NOTE: A Complete Rotor Repair Kit is recommended when wear or damage exists on the rotor (7) and the outer bearing races located in the sensor-side stator cap (12) and preload hub (8).

If a complete re-build is not required, individual Rotor Kits are available.

Stator Cap Kits

Model	Kit No.	Kits include
i30 (QTC)	25V129	<ul style="list-style-type: none"> 1 sensor-side stator cap (12) 1 load-side stator cap (13)
h30 (QHC)	25V130	
i80 (QTD)	25V131	
h80 (QHD)	25V132	
i120 (QTE)	25V133	
h120 (QHE)	25V134	

Rotor Kits

Model	Kit No.	Kits include
i30 (QTC)	25F122	<ul style="list-style-type: none"> 1 rotor (7) with bearing 1 shaft (7a)
h30 (QHC)		
i80 (QTD)	25F123	<ul style="list-style-type: none"> 2 fasteners (For shipping purposes only. Discard.) 2 washers (For shipping purposes only. Discard.)
h80 (QHD)		
i120 (QTE)	25F124	
h120 (QHE)		

Cord/Cable Kits

Location	Model	Motor Configuration Code	Kit No.
Ordinary Locations	h30 (QHC)	F-1	19B738*
	i80 (QTD)		
	h80 (QHD)		
	i120 (QTE)		
Hazardous (Classified) Locations	h120 (QHE)	F-2	19B739*
	i30 (QTC)		
	h30 (QHC)		
	i80 (QTD)		
Hazardous (Classified) Locations	h80 (QHD)	F-3	2001047†
	i120 (QTE)		
	h120 (QHE)		
	i30 (QTC)		
	h30 (QHC)		
	i80 (QTD)		
Explosive Atmospheres	h120 (QHE)	F-5	19B740*
	i30 (QTC)		
	h30 (QHC)		
	i80 (QTD)		
Explosive Atmospheres	h80 (QHD)	F-6	2001047†
	i120 (QTE)		
	h120 (QHE)		
	i30 (QTC)		
	h30 (QHC)		
	i80 (QTD)		
Explosive Atmospheres	h120 (QHE)	F-4	19B823*
	i30 (QTC)		
	h30 (QHC)		
	i80 (QTD)		
	h80 (QHD)		

*** Kits include:**

- 1 power cord/cable (38)

† Kits include:

- 1 power cord/cable (38)
- 1 bushing strain relief (34)

Fan Kits

Model	Kit No.	Kits include:
3-Phase Fans	25F100	<ul style="list-style-type: none"> • 1 bearing sleeve (23) • 1 fan motor (24) • 1 fan propeller (25) • 1 cable tie • 1 fan press tool
	25F101	<ul style="list-style-type: none"> • 1 fan propeller (25) • 1 fan press tool

Motor Reseal Kit

Model	Kit No.	Kits include:
All	2006210	<ul style="list-style-type: none"> • 2 seal, FKM (11) • 2 o-ring, Buna-N (47) • 2 gasket, stator (83)

Control Knob Kits

Model	Kit No.	Description
Industrial (QT)	25F102	For Industrial (QT) models in Ordinary Locations
	25F103	For Industrial (QT) models in Explosive Atmospheres or Hazardous (Classified) Locations
Hygienic (QH)	25F104	For Hygienic (QH) models in Ordinary Locations
	25F105	For Hygienic (QH) models in Explosive Atmospheres or Hazardous (Classified) Locations
Kits include: <ul style="list-style-type: none"> • 1 control knob bracket (20) • 2 fasteners (20a) • 1 control encoder (21) • 1 push nut (21a) • 1 control knob (22) with 2 fasteners, hex head (22a) • 1 seal (22b) • 1 packet of anti-seize lubricant 		

Motor Sensor Kits

Model	Kit No.	Kits include:
i30 (QTC) h30 (QHC) i80 (QTD) h80 (QHD) i120 (QTE) h120 (QHE)	25F120	<ul style="list-style-type: none"> • 1 motor sensor assembly (4)

Control Board Kits

Model	Voltage	Kit No.	Kits include:
i30, h30 (QTC, QHC)	120 V, 240 V 3-phase	25F113	<ul style="list-style-type: none"> 1 board assembly 1 tube thermal paste
i80, h80 (QTD, QHD)		25F114	
i120, h120, (QTE, QHE, QHF)		25F115	
i30, h30 (QTC, QHC)	230 V Single-phase	25F117	<ul style="list-style-type: none"> 1 board assembly 1 tube thermal paste 1 board assembly line filter
i80, h80 (QTD, QHD)		25F118	
i120, h120 (QTE, QHE, QHF)		25F119	

Accessory Kits

Accessory kits are available (purchase separately).

Leak Sensor Kits

Locations	Kit No.	Kits include:
Ordinary Locations	25F108	<ul style="list-style-type: none"> 1 level switch sensor 1 reducer fitting 2 elbow swivels (1/4 in. NPT, 3/8 in. hose port) 1 tee union 1 hose (30 in. long, 3/8 in. outer diameter) 1 breather
Explosive Atmospheres or Hazardous (Classified) Locations	25F109	<ul style="list-style-type: none"> 1 level switch sensor 2 elbow swivels (1/4 in. NPT, 3/8 in. hose port) 1 tee union 1 hose (30 in. long, 3/8 in. outer diameter) 1 elbow swivel (1/8 in. NPT) 1 hose (20 in. long, 1/4 in. outer diameter) 1 pipe bushing 1 elbow (1/4 in. NPT; 1/4 in. hose port)

Preload Nut Installation Tool Kits

Kit No.	Kits include:
25V370	<ul style="list-style-type: none"> 2 preload installation plates

Rotor Greasing Tool Kits

Kit No.	Kits include:
25V176	<ul style="list-style-type: none"> 1 greaser cartridge 1 packet of lubricant

I/O Cable Kits

Model	Kit No.	Kits include:
Models in Explosive Atmospheres or Hazardous (Classified) Locations	25V080	<ul style="list-style-type: none"> 1 gland, 3/4 in. NPT 1 cable 1 cable clamp 2 fasteners 1 ground fastener

Maintenance Bracket Stand

Kit No.	Kits include:
18F978	STAND, maintenance bracket

Electrical Schematics

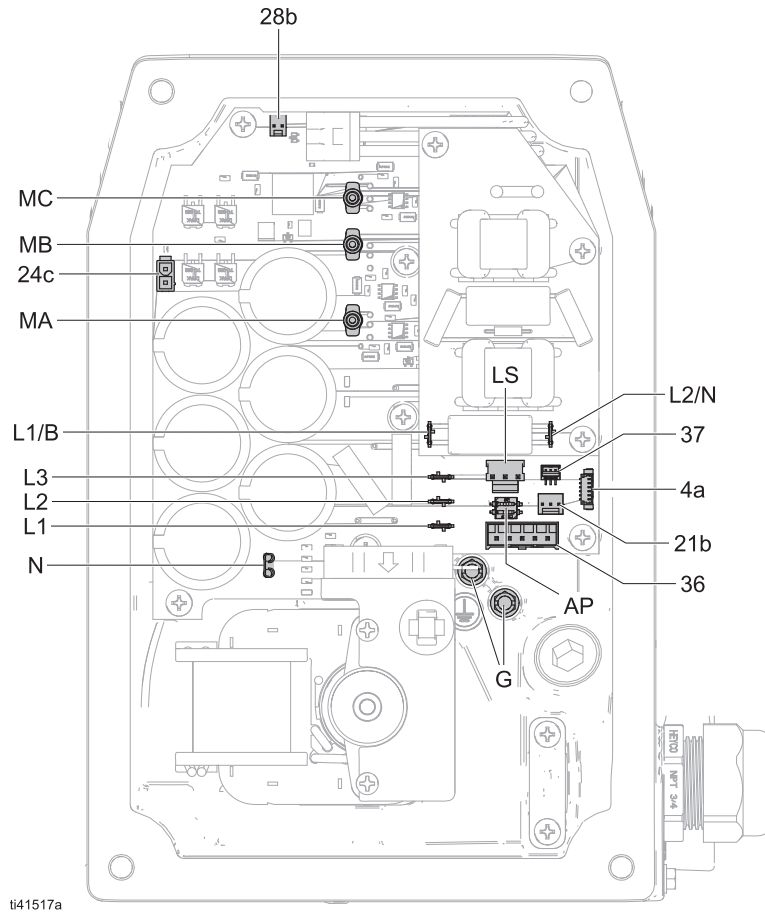

t41517a

Key: Power Cord/Cable Schematics							
Motor	Power Cord/Cable Wire Connection						
	N	L1	L2	L3	L1/B	L2/N	G
F-1, F-3	---	Black	White	Red	---	---	Green (ground wire)
F-2, F-4	---	---	---	---	Brown (filter board)	Blue (filter board)	
F-5, F-6	White	Black	---	---	---	---	

Key: General Electrical Schematics	
4a	Motor sensor cable
21b	Control knob encoder wire
28b	Fan cable
24c	Fan motor cable
36	I/O port/cable
37	LED indicator

Key: General Electrical Schematics	
LS	Leak Sensor
AP	DIP Switch 2 Auto Prime; DIP Switch 1 Leak Sensor
MA	Motor wire: black wire, white band
MB	Motor wire: black wire, black band
MC	Motor wire: black wire, red band

Technical Specifications

QUANTM Electric Motor				
	US	Metric		
Environmental temperature range	-4° to 104°F	-20° to 40°C		
IP Ratings:				
Ordinary Locations Models	IP66, Type 4X			
Explosive Atmospheres or Hazardous (Classified) Locations Models	IP66, Type 4X			
Electrical Ratings				
	Rated Voltage	Phase	Hertz	Current
h30 (QHC) models, F-1 motor	200–240 V	3	50/60 Hz	7.5 A
i30 (QTC) and h30 (QHC) models, F-2 motor	200–240 V	1	50/60 Hz	10 A
h30 (QHC) models, F-3 motor	200–240 V	3	50/60 Hz	7.5 A
i30 (QTC) and h30 (QHC) models, F-4 motor	200–240 V	1	50/60 Hz	10 A
i30 (QTC) and h30 (QHC) models, F-5 motor	100–120 V	1	50/60 Hz	12 A
i30 (QTC) and h30 (QHC) models, F-6 motor	100–120 V	1	50/60 Hz	12 A
i80 (QTD) and h80 (QHD) models, F-1 motor	200–240 V	3	50/60 Hz	7.5 A
i80 (QTD) and h80 (QHD) models, F-2 motor	200–240 V	1	50/60 Hz	15 A
i80 (QTD) and h80 (QHD) models, F-3 motor	200–240 V	3	50/60 Hz	7.5 A
i80 (QTD) and h80 (QHD) models, F-4 motor	200–240 V	1	50/60 Hz	15 A
i120 (QTE) and h120 (QHE) models, F-1 motor	200–240 V	3	50/60 Hz	7.5 A
i120 (QTE) and h120 (QHE) models, F-2 motor	200–240 V	1	50/60 Hz	15 A
i120 (QTE) and h120 (QHE) models, F-3 motor	200–240 V	3	50/60 Hz	7.5 A
i120 (QTE) and h120 (QHE) models, F-4 motor	200–240 V	1	50/60 Hz	15 A
Notes				
All trademarks or registered trademarks are the property of their respective owners.				

California Proposition 65

CALIFORNIA RESIDENTS

 **WARNING:** Cancer and reproductive harm – www.P65warnings.ca.gov.

Graco Standard Warranty

Graco warrants all equipment referenced in this document which is manufactured by Graco and bearing its name to be free from defects in material and workmanship on the date of sale to the original purchaser for use. With the exception of any special, extended, or limited warranty published by Graco, Graco will, for a period of twelve months from the date of sale, repair or replace any part of the equipment determined by Graco to be defective. This warranty applies only when the equipment is installed, operated and maintained in accordance with Graco's written recommendations.

This warranty does not cover, and Graco shall not be liable for general wear and tear, or any malfunction, damage or wear caused by faulty installation, misapplication, abrasion, corrosion, inadequate or improper maintenance, negligence, accident, tampering, or substitution of non-Graco component parts. Nor shall Graco be liable for malfunction, damage or wear caused by the incompatibility of Graco equipment with structures, accessories, equipment or materials not supplied by Graco, or the improper design, manufacture, installation, operation or maintenance of structures, accessories, equipment or materials not supplied by Graco.

This warranty is conditioned upon the prepaid return of the equipment claimed to be defective to an authorized Graco distributor for verification of the claimed defect. If the claimed defect is verified, Graco will repair or replace free of charge any defective parts. The equipment will be returned to the original purchaser transportation prepaid. If inspection of the equipment does not disclose any defect in material or workmanship, repairs will be made at a reasonable charge, which charges may include the costs of parts, labor, and transportation.

THIS WARRANTY IS EXCLUSIVE, AND IS IN LIEU OF ANY OTHER WARRANTIES, EXPRESS OR IMPLIED, INCLUDING BUT NOT LIMITED TO WARRANTY OF MERCHANTABILITY OR WARRANTY OF FITNESS FOR A PARTICULAR PURPOSE.

Graco's sole obligation and buyer's sole remedy for any breach of warranty shall be as set forth above. The buyer agrees that no other remedy (including, but not limited to, incidental or consequential damages for lost profits, lost sales, injury to person or property, or any other incidental or consequential loss) shall be available. Any action for breach of warranty must be brought within two (2) years of the date of sale.

GRACO MAKES NO WARRANTY, AND DISCLAIMS ALL IMPLIED WARRANTIES OF MERCHANTABILITY AND FITNESS FOR A PARTICULAR PURPOSE, IN CONNECTION WITH ACCESSORIES, EQUIPMENT, MATERIALS OR COMPONENTS SOLD BUT NOT MANUFACTURED BY GRACO. These items sold, but not manufactured by Graco (such as electric motors, switches, hose, etc.), are subject to the warranty, if any, of their manufacturer. Graco will provide purchaser with reasonable assistance in making any claim for breach of these warranties.

In no event will Graco be liable for indirect, incidental, special or consequential damages resulting from Graco supplying equipment hereunder, or the furnishing, performance, or use of any products or other goods sold hereto, whether due to a breach of contract, breach of warranty, the negligence of Graco, or otherwise.

FOR GRACO CANADA CUSTOMERS

The Parties acknowledge that they have required that the present document, as well as all documents, notices and legal proceedings entered into, given or instituted pursuant hereto or relating directly or indirectly hereto, be drawn up in English. Les parties reconnaissent avoir convenu que la rédaction du présente document sera en Anglais, ainsi que tous documents, avis et procédures judiciaires exécutés, donnés ou intentés, à la suite de ou en rapport, directement ou indirectement, avec les procédures concernées.

Graco Information

For the latest information about Graco products, visit www.graco.com.

For patent information, see www.graco.com/patents.

TO PLACE AN ORDER, contact your Graco distributor or call to identify the nearest distributor.

Phone: 612-623-6921 **or Toll Free:** 1-800-328-0211, **Fax:** 612-378-3505

*All written and visual data contained in this document reflects the latest product information available at the time of publication.
Graco reserves the right to make changes at any time without notice.*

Original instructions. This manual contains English. MM 3A7637

Graco Headquarters: Minneapolis

International Offices: Belgium, China, Japan, Korea

GRACO INC. AND SUBSIDIARIES • P.O. BOX 1441 • MINNEAPOLIS MN 55440-1441 • USA
Copyright 2022, Graco Inc. All Graco manufacturing locations are registered to ISO 9001.

www.graco.com
Revision E, December 2023