

ThermoLazer[®] 200/200Tc/300Tc and ThermoLazer ProMelt[™] Pavement Marking Systems

3A1319L

EN

- For professional application of thermoplastic traffic marking compound materials (reflective beads applied simultaneously with screeding) -
- For outdoor use only (not to be operated in rain or damp conditions) -

Fuel: LP Gas (Propane Vapor)

Burner capacities: See **Technical Data**, page 38.

Material capacity (max): 200-300 lb (91-136 kg)



IMPORTANT SAFETY INSTRUCTIONS

Read all warnings and instructions in this manual. Save these instructions.

Related Manuals:

Repair	3A1320
Parts	3A1321
Double Bead Box	3A0004
SmartDie [™] II	3A1738
FlexDie [™]	3A1738

ThermoLazer 200/200Tc

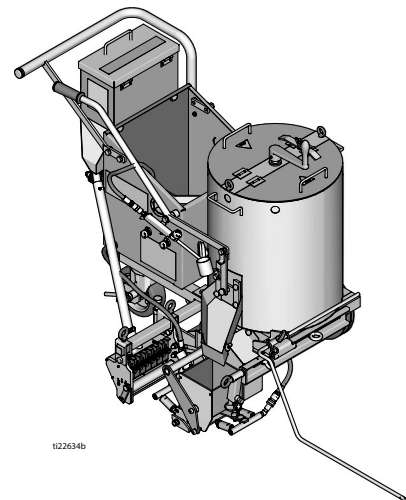

ti2634b

ThermoLazer ProMelt

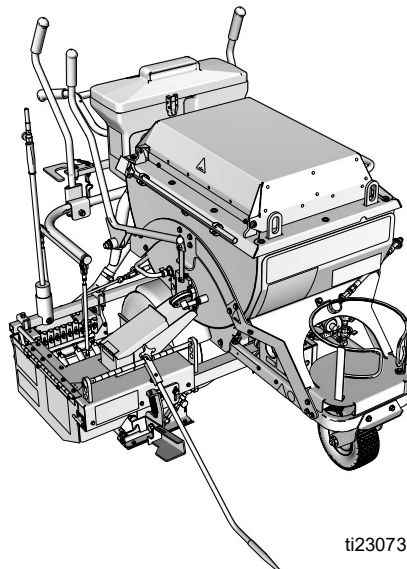

ti23073a

ThermoLazer 300Tc

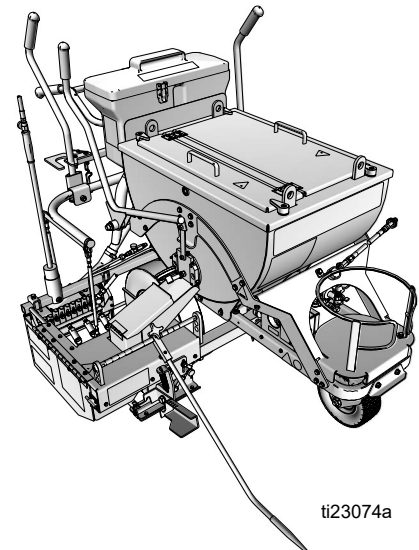

ti23074a

System Chart

SmartDie II used on ThermoLazer 300TC and ProMelt only.

Smart Die II Part No.	Smart Die Description
17A173	2 in. (5 cm)
24H431	3 in. (8 cm)
24H426	4 in. (10 cm)
17J250	4.75 in. (12 cm)
24H432	5 in. (13 cm)
24H427	6 in. (15 cm)
24H433	7 in. (18 cm)
24H428	8 in. (20 cm)
24H434	9 in. (22.5 cm)
24H429	10 in. (25 cm)
24H430	12 in. (30 cm)
‡17A174	16 in. (41 cm)
24H437	3-3-3 in. (8-8-8 cm)
24H435	4-3-4 in. (10-8-10 cm)
24H436	4-4-4 in. (10-10-10 cm)
24J785	4-6-4 in. (10-15-10 cm)
‡17A175	6-4-6 in. (15-10-15 cm)
‡17R738	5-5-5 in. (13-13-13 cm)
‡26C273	6-3-6 in. (15-8-15 cm)

‡ Requires 16" (40 cm) Conversion Bead System Kit for 300TC/ProMelt Only.

- 17B190 Kit, accy, 16" (40 cm) Single Drop Bead System
- 17B189 Kit, accy, 16" (40 cm) Double Drop Bead Box (requires 17B190 to be installed)

FlexDie used on ThermoLazer 200/200TC only.







FlexDie Part No.	FlexDie Description
16Y661	2 in. (5 cm)
16Y662	3 in. (8 cm)
16Y320	4 in. (10 cm)
16Y663	5 in. (12 cm)
16Y190	6 in. (15 cm)
16Y664	7 in. (18 cm)
16Y326	8 in. (20 cm)
16Y665	9 in. (22.5 cm)
16Y332	10 in. (25 cm)
16Y207	12 in. (30 cm)
16Y338	3-3-3 in. (8-8-8 cm)
16Y352	4-3-4 in. (10-8-10 cm)
16Y666	4-2-4 in. (10-5-10 cm)
16Y363	4-4-4 in. (10-10-10 cm)

Contents

System Chart	2	Screed Box ThermoLazer 200/200TC (FlexDie) ..	23
Contents	3	Installation	23
Warnings	4	Removal	24
Component Identification - ThermoLazer 200	6	Adjustments	25
Component Identification - ThermoLazer 200		Screed Box ThermoLazer 300TC/ProMelt (SmartDie	26
(continued)	7	II)	26
Component Identification - ThermoLazer 200TC .	8	Installation	26
Component Identification - ThermoLazer 200TC		Removal	26
(Continued)	9	Adjustment	27
Component Identification - ThermoLazer 300TC 10		Screed Box Line Thickness Adjustment	28
Component Identification - ThermoLazer 300TC		Preparing ThermoLazer 200/200TC/300TC for	
(Continued)	11	Application	29
Component Identification - ThermoLazer ProMelt 12		Preparing ThermoLazer ProMelt for Application 30	
Component Identification - ThermoLazer ProMelt		ProMelt Overheating Protection	31
(Continued)	13	Bead Dispenser Box	31
Important Safety Information	14	Adding Beads to SplitBead Hopper	31
Important Safety Information	15	Applying Material to a Surface	32
Important Safety Information	16	Shutting Down	33
Lighting Instructions	17	Clean-Up for ThermoLazer 200/200TC/300TC ...	34
Lighting Kettle Burners	17	Transporting	34
Shutting Off Burner	19	Clean-Up for ThermoLazer ProMelt	35
Torch Lighting Instructions	20	Transporting	35
Front Screed Box Burner		Maintenance	36
Lighting Instructions	21	FatTrack Front Swivel Wheel System	37
Rear Screed Box Burner		Technical Data	38
Lighting Instructions (ThermoLazer		Notes	39
300TC/ProMelt)	22	Graco Standard Warranty	40

Warnings

The following warnings are for the setup, use, grounding, maintenance, and repair of this equipment. The exclamation point symbol alerts you to a general warning and the hazard symbols refer to procedure-specific risks. When these symbols appear in the body of this manual or on warning labels, refer back to these Warnings. Product-specific hazard symbols and warnings not covered in this section may appear throughout the body of this manual where applicable.

 WARNING	
	<p>FIRE AND EXPLOSION HAZARD</p> <p>Flammable fumes and liquids, such as propane gas, gasoline and combustible fuel, in work area can ignite or explode. To help prevent fire and explosion:</p> <ul style="list-style-type: none"> • Do not use equipment unless fully trained and qualified. • Do not allow open containers of flammables within 25 ft (7.6 m) of equipment. Do not operate equipment within 10 ft (3 m) of any structure, combustible material, or other gas cylinders. • Shut off all burners when adding fuel to equipment. • Close the tank shut-off valve immediately if you smell propane gas; extinguish all open flames. If gas odor continues, keep away from equipment and immediately call the fire department. • Follow lighting instructions for the burner and torch. • Do not heat thermoplastic traffic marking compound material above its maximum temperature rating. • Fire extinguisher equipment shall be present and working. • Keep work area free of debris, including solvent, rags and gasoline.
	<p>EQUIPMENT MISUSE HAZARD</p> <p>Misuse can cause death or serious injury.</p> <ul style="list-style-type: none"> • Do not leave equipment unattended. • Keep children and animals away from work area. • Do not exceed the maximum working pressure or temperature rating of the lowest rated system component. See Technical Data in all equipment manuals. • Check equipment daily. Repair or replace worn or damaged parts immediately with genuine manufacturer's replacement parts only. • Do not alter or modify equipment. • Use equipment only for its intended purpose. Call your Graco distributor for information. • Do not fill material beyond maximum capacity. • Route gas lines, hoses, wires and cables away from traffic areas, sharp edges, moving parts, and hot surfaces. • Do not kink or overbend gas lines. • Do not override or defeat safety devices. • Do not operate the unit when fatigued or under the influence of drugs or alcohol.
	<p>BURN HAZARD</p> <p>Equipment surfaces and fluid that is heated can become very hot during operation. To avoid severe burns:</p> <ul style="list-style-type: none"> • Do not touch hot fluid or equipment.
	<p>CARBON MONOXIDE HAZARD</p> <p>Exhaust contains poisonous carbon monoxide, which is colorless and odorless. Breathing carbon monoxide can cause death.</p> <ul style="list-style-type: none"> • Do not operate in an enclosed area.
	<p>TOXIC FLUID OR FUMES HAZARD</p> <p>Toxic fluids or fumes can cause serious injury or death if splashed in the eyes or on skin, inhaled, or swallowed.</p> <ul style="list-style-type: none"> • Read MSDSs to know the specific hazards of the fluids you are using. • Store hazardous fluid in approved containers, and dispose of it according to applicable guidelines.

WARNING



PERSONAL PROTECTIVE EQUIPMENT

Wear appropriate protective equipment when in the work area to help prevent serious injury, including eye injury, hearing loss, inhalation of toxic fumes, and burns. This protective equipment includes but is not limited to:

- Clothing and respirator as recommended by the fluid, material, and solvent manufacturer.
- Gloves, shoes, overalls, face shield, hat, etc. rated for elevated temperatures of at least 500° F (260° C).

CALIFORNIA PROPOSITION 65

Exhaust from this product contains a chemical known to the State of California to cause cancer, birth defects or other reproductive harm.

CALIFORNIA PROPOSITION 65

This product contains a chemical known to the State of California to cause cancer, birth defects or other reproductive harm. Wash hands after handling.

Component Identification - ThermoLazer 200

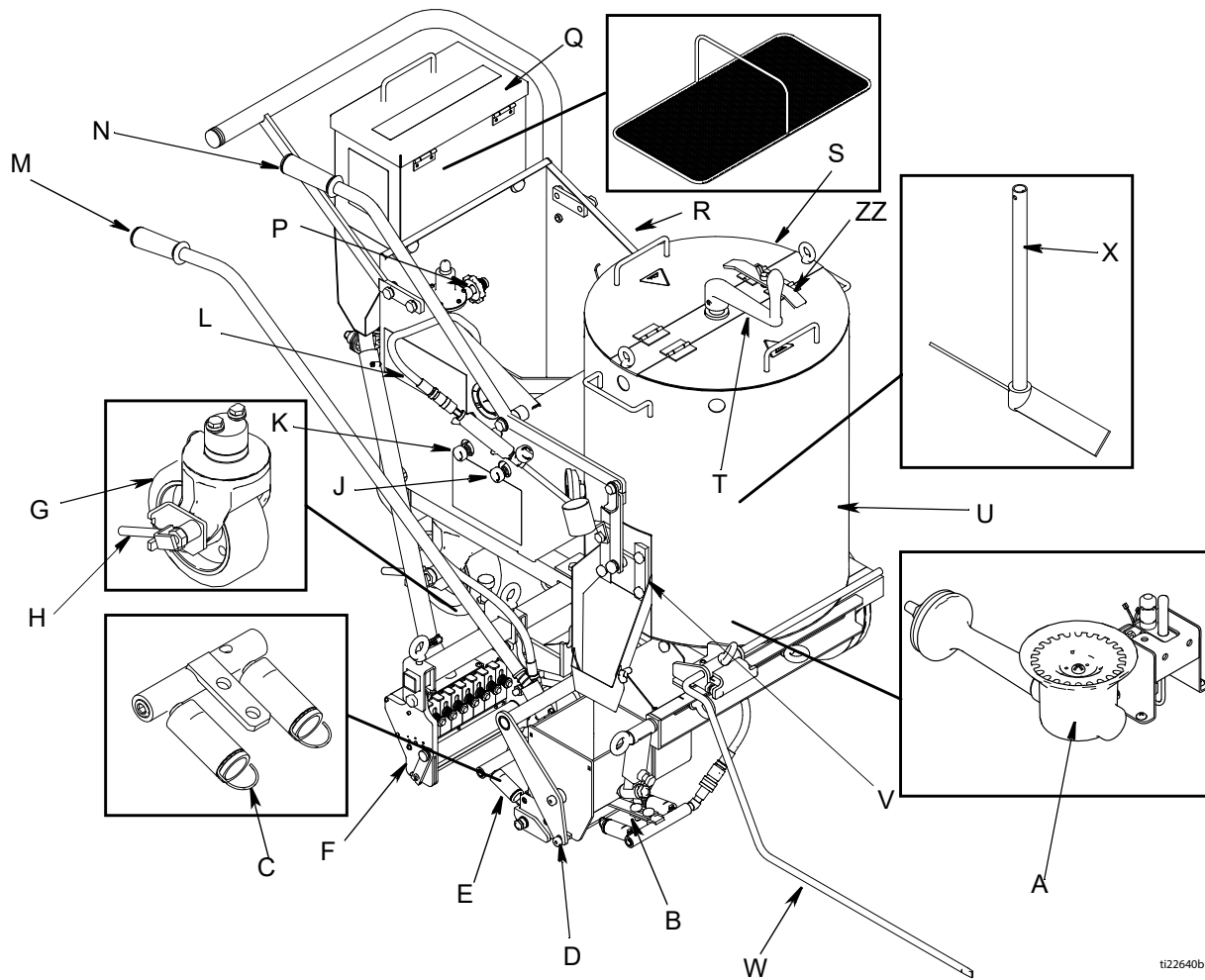

ti22640b

A	Kettle Main Burner
B	Front Screenshot Burners
C	Flame Indicator
D	Screenshot Box (FlexDie)
E	Rear Screenshot Burners
F	Bead Dispenser Box
G	Rear Swivel Wheel
H	Rear Swivel Unlock Lever
J	Front Screenshot Box Manual Shut-Off
K	Rear Screenshot Box Manual Shut-Off
L	Torch
M	Screenshot Box/Bead Dispenser Box Actuator

N	ControlFlow™ Gate Valve Actuator
P	Propane Tank Connector
Q	Bead Hopper
R	LP Gas Cylinder Holder
S	Access Cover
T	Agitator Crank
U	Kettle
V	ControlFlow Gate Valve
W	Line Guide
X	Agitator
ZZ	Kettle Lid Lock

*LP-Gas supply cylinder not supplied by Graco. LP-Gas supply cylinder must be designed, fabricated, and marked in accordance with specifications and regulators for LP-Gas cylinders at The U.S. Department of Transportation (DOT), The National Standard of Canada, CAN/CSA-B339, Cylinders, Spheres, and Tubes for Transportation of Dangerous Goods, The Transportable Pressure Vessels Regulators 2001 (S1 2001/1426), The Gas Cylinders (Pattern Approval) Regulations 1987 (SI 1987/116)(Pattern Approval Regulations) for EEC-type cylinders under European Directive 84/525/EEC, 84/526/EEC, and 84/527/EEC.

Component Identification - ThermoLazer 200 (continued)

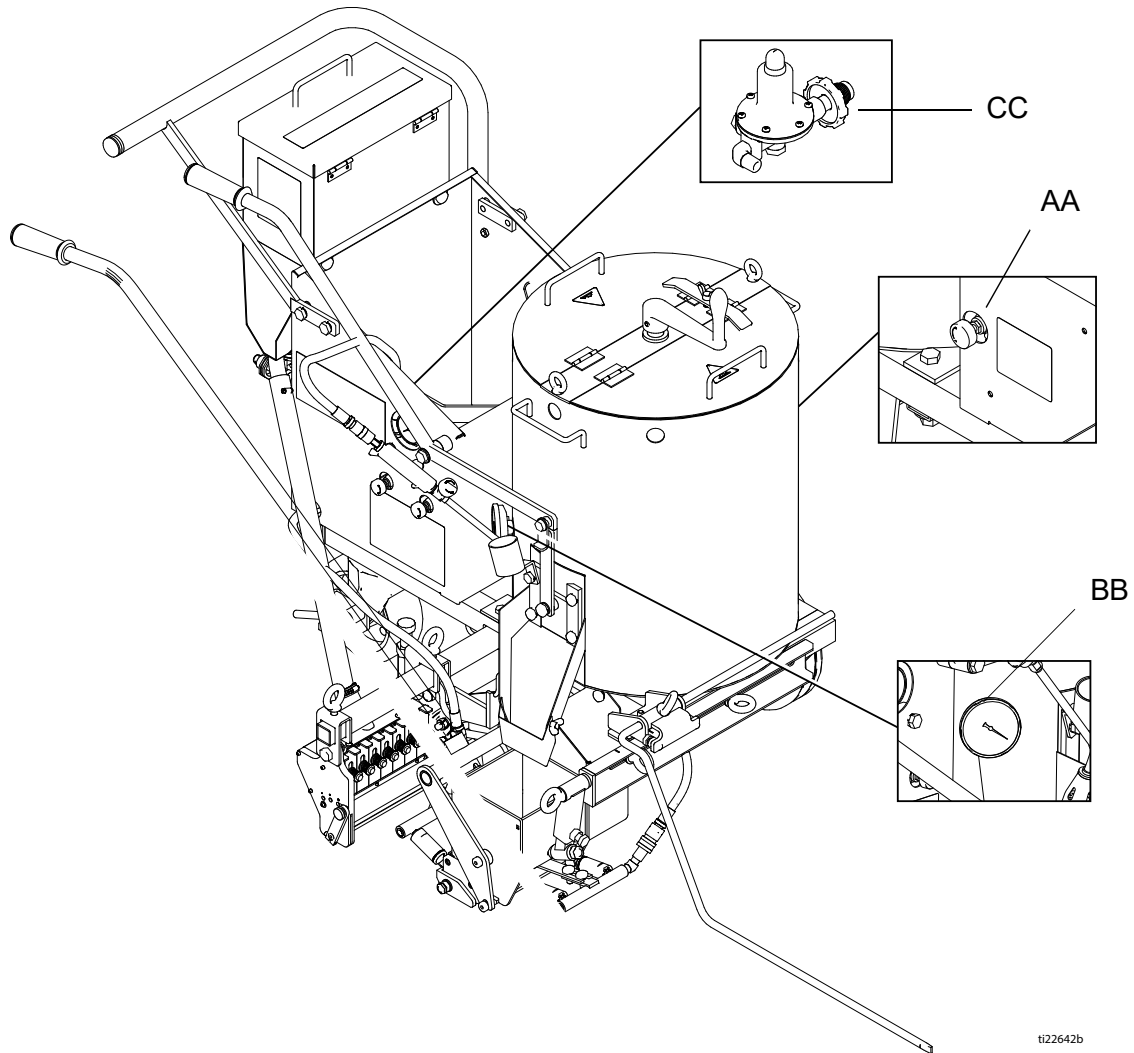

AA	Kettle Temperature Control Knob
BB	Kettle Temperature Indicator

CC	System Regulator
----	------------------

t122642b

Component Identification - ThermoLazer 200TC

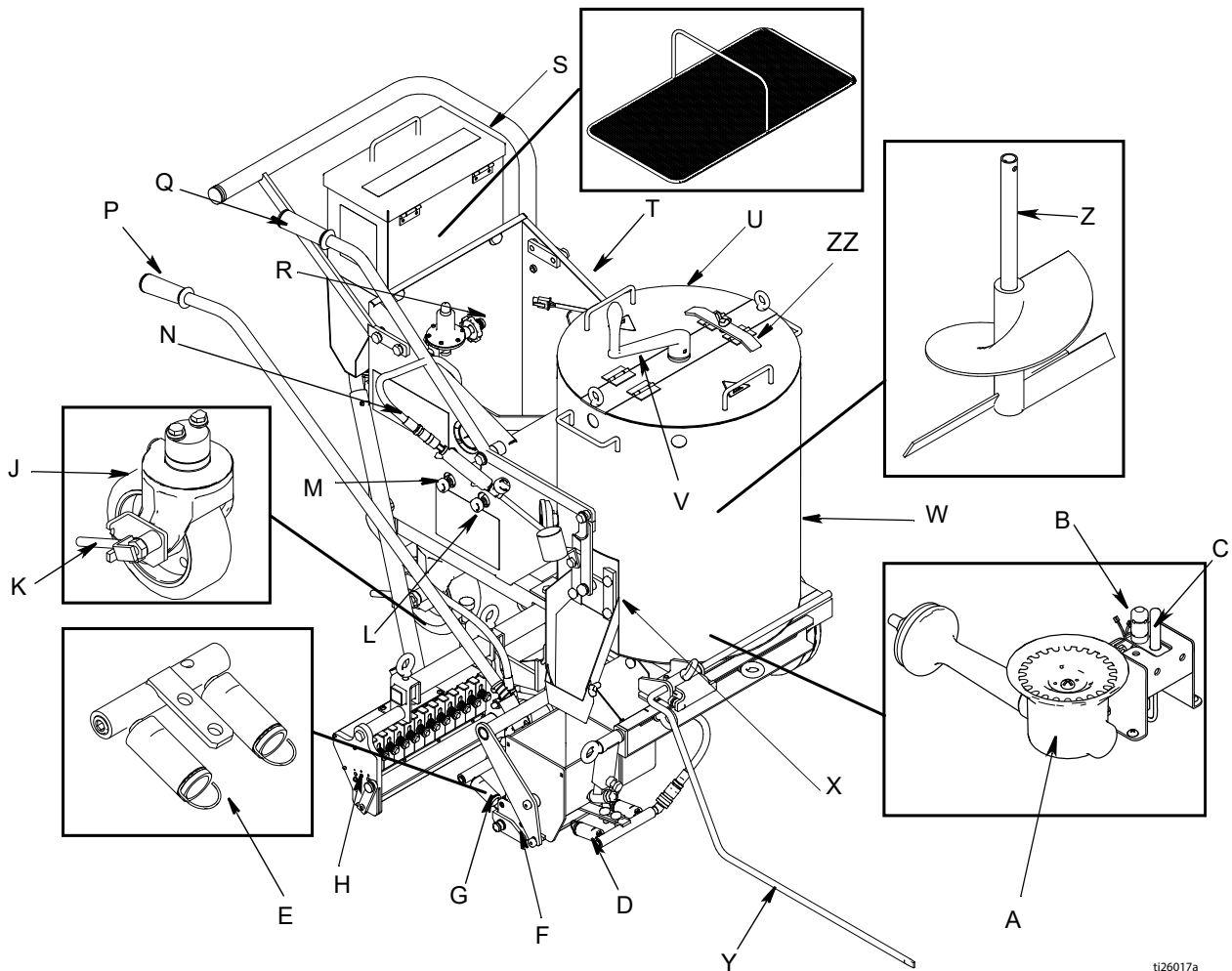

ti26017a

A	Kettle Main Burner
B	Kettle Pilot Burner
C	Kettle Thermopile
D	Front Screenshot Box Burners
E	Flame Indicator
F	Screenshot Box (FlexDie)
G	Rear Screenshot Box Burners
H	Bead Dispenser Box
J	Rear Swivel Wheel
K	Rear Swivel Unlock Lever
L	Front Screenshot box Manual Shut-Off
M	Rear Screenshot Box Manual Shut-Off
N	Torch

P	Screenshot Box/Bead Dispense Box Actuator
Q	ControlFlow Gate Valve Actuator
R	Propane Tank Connector
S	Bead Hopper
T	LP Gas Cylinder Holder
U	Access Cover
V	Agitator Crank
W	Kettle
X	ControlFlow Gate Valve
Y	Line Guide
Z	Agitator
ZZ	Kettle Lid Lock

*LP-Gas supply cylinder not supplied by Graco. LP-Gas supply cylinder must be designed, fabricated, and marked in accordance with specifications and regulators for LP-Gas cylinders at The U.S. Department of Transportation (DOT), The National Standard of Canada, CAN/CSA-B339, Cylinders, Spheres, and Tubes for Transportation of Dangerous Goods, The Transportable Pressure Vessels Regulators 2001 (S1 2001/1426), The Gas Cylinders (Pattern Approval) Regulations 1987 (SI 1987/116)(Pattern Approval Regulations) for EEC-type cylinders under European Directive 84/525/EEC, 84/526/EEC, and 84/527/EEC.

Component Identification - ThermoLazer 200TC (Continued)

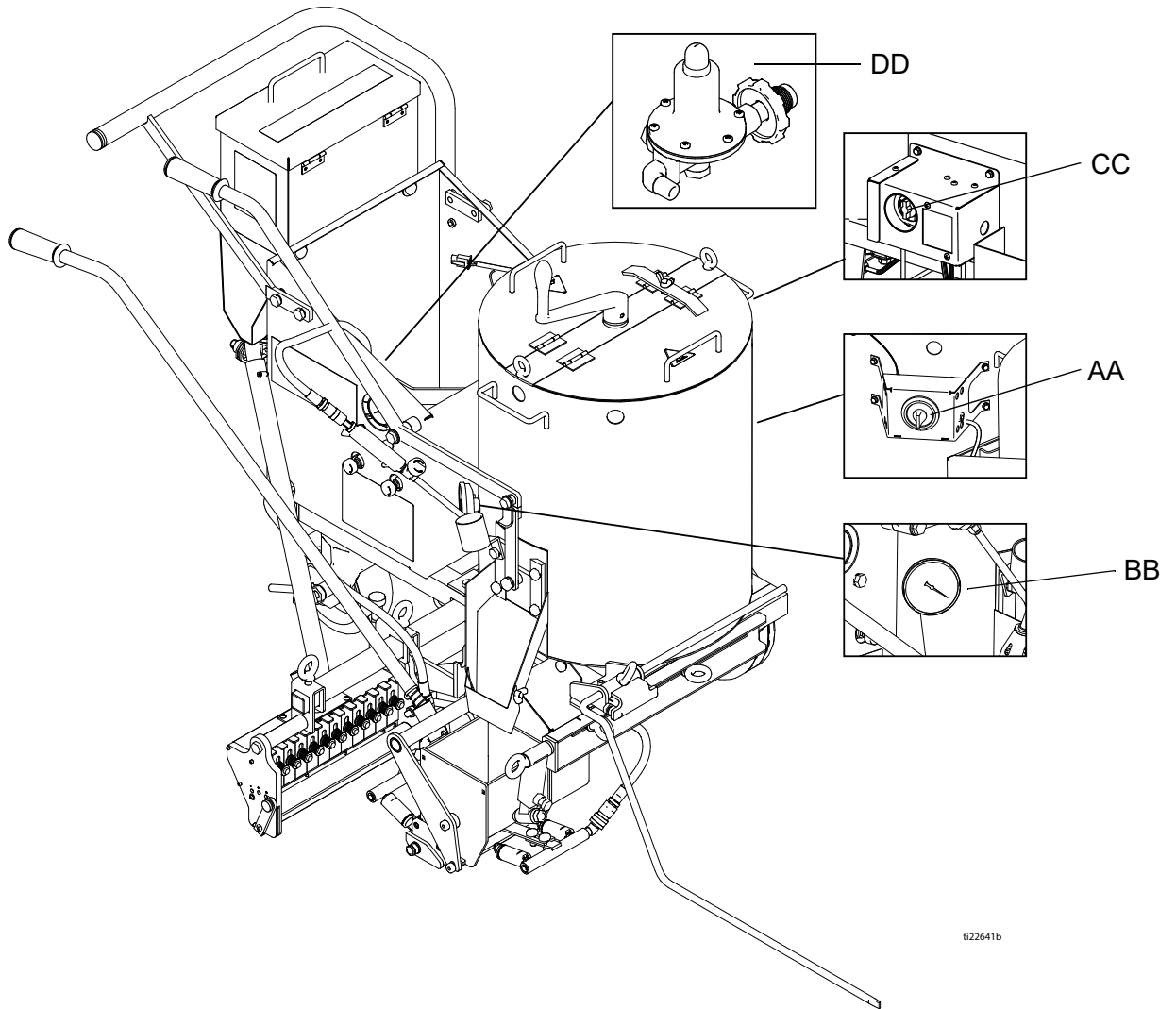

t122641b

AA	Kettle Temperature Control Knob
BB	Kettle Temperature Indicator
CC	Kettle Gas Safety Valve
DD	System Regulator

Component Identification - ThermoLazer 300TC

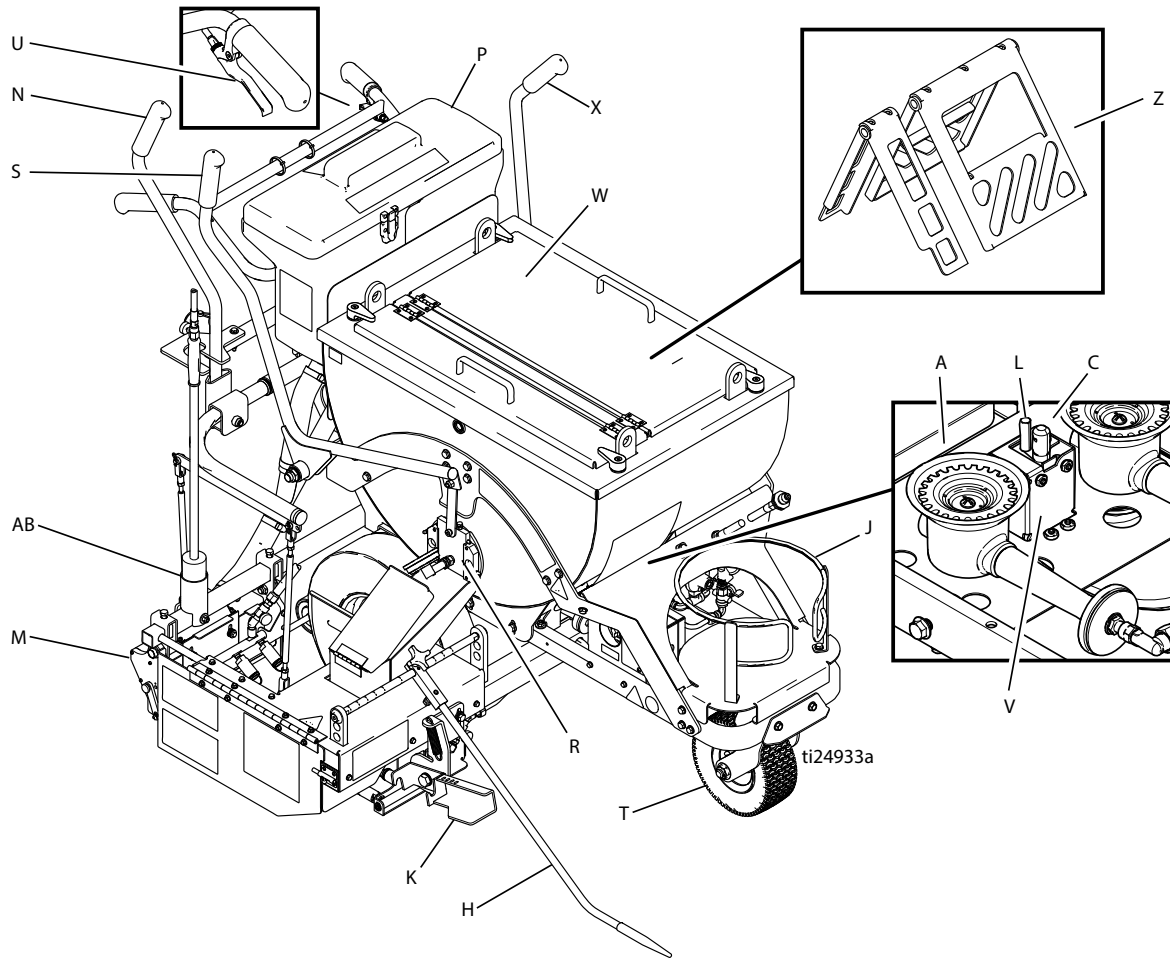

A	Kettle Main Burners (2)
C	Kettle Pilot Burner
H	Line Guide
J	LP Gas Cylinder Holder
K	Screed Box Lever
L	Kettle Thermopile
M	Bead Dispenser Box
N	Screed Box/Bead Dispenser Box Actuator
P	SplitBead™ Hopper

R	ControlFlow Gate Valve
S	ControlFlow Gate Valve Actuator
T	FatTrack Swivel Tire
U	Front Swivel Unlock Lever
V	Kettle Pilot Igniter Electrode
W	Access Cover with Latches
X	Agitator Actuator
Z	Agitators
AB	Torch

*LP-Gas supply cylinder not supplied by Graco. LP-Gas supply cylinder must be designed, fabricated, and marked in accordance with specifications and regulators for LP-Gas cylinders at The U.S. Department of Transportation (DOT), The National Standard of Canada, CAN/CSA-B339, Cylinders, Spheres, and Tubes for Transportation of Dangerous Goods, The Transportable Pressure Vessels Regulators 2001 (S1 2001/1426), The Gas Cylinders (Pattern Approval) Regulations 1987 (SI 1987/116)(Pattern Approval Regulations) for EEC-type cylinders under European Directive 84/525/EEC, 84/526/EEC, and 84/527/EEC.

Component Identification - ThermoLazer 300TC (Continued)

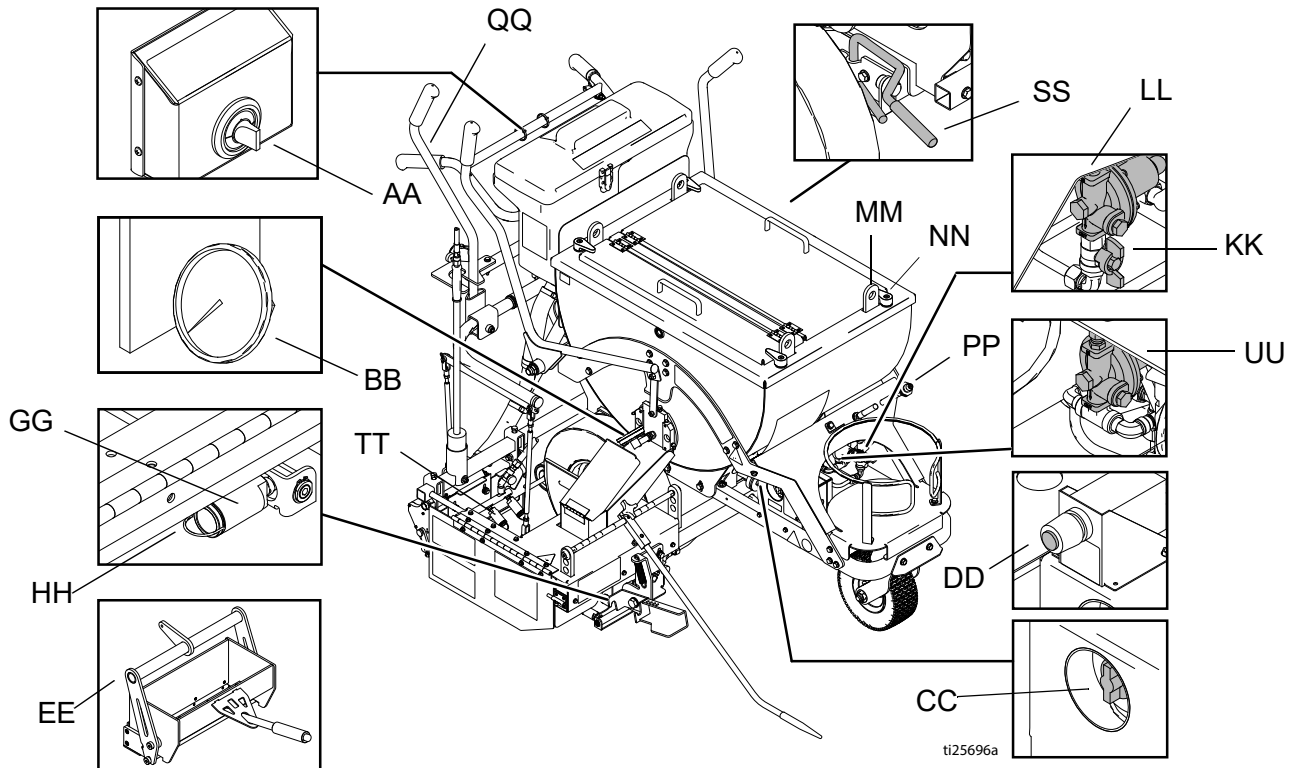

ti25696a

AA	Kettle Temperature Control Knob
BB	Kettle Temperature Indicator
CC	Kettle Gas Safety Valve
DD	Kettle Pilot Burner Igniter
EE	Screed Box (SmartDie II)
GG	Front Screed Box Burners
HH	Flame Indicator
KK	Kettle Burners Manual Shut-Off Valve
LL	Kettle Burner Regulator
MM	Lifting Ring
NN	Lid/Lever Latch
PP	Propane Tank Connector
QQ	Torch Igniter
SS	Parking Brake
TT	Rear Screed Box Burners
UU	Screed Box Burners Regulator

Component Identification - ThermoLazer ProMelt

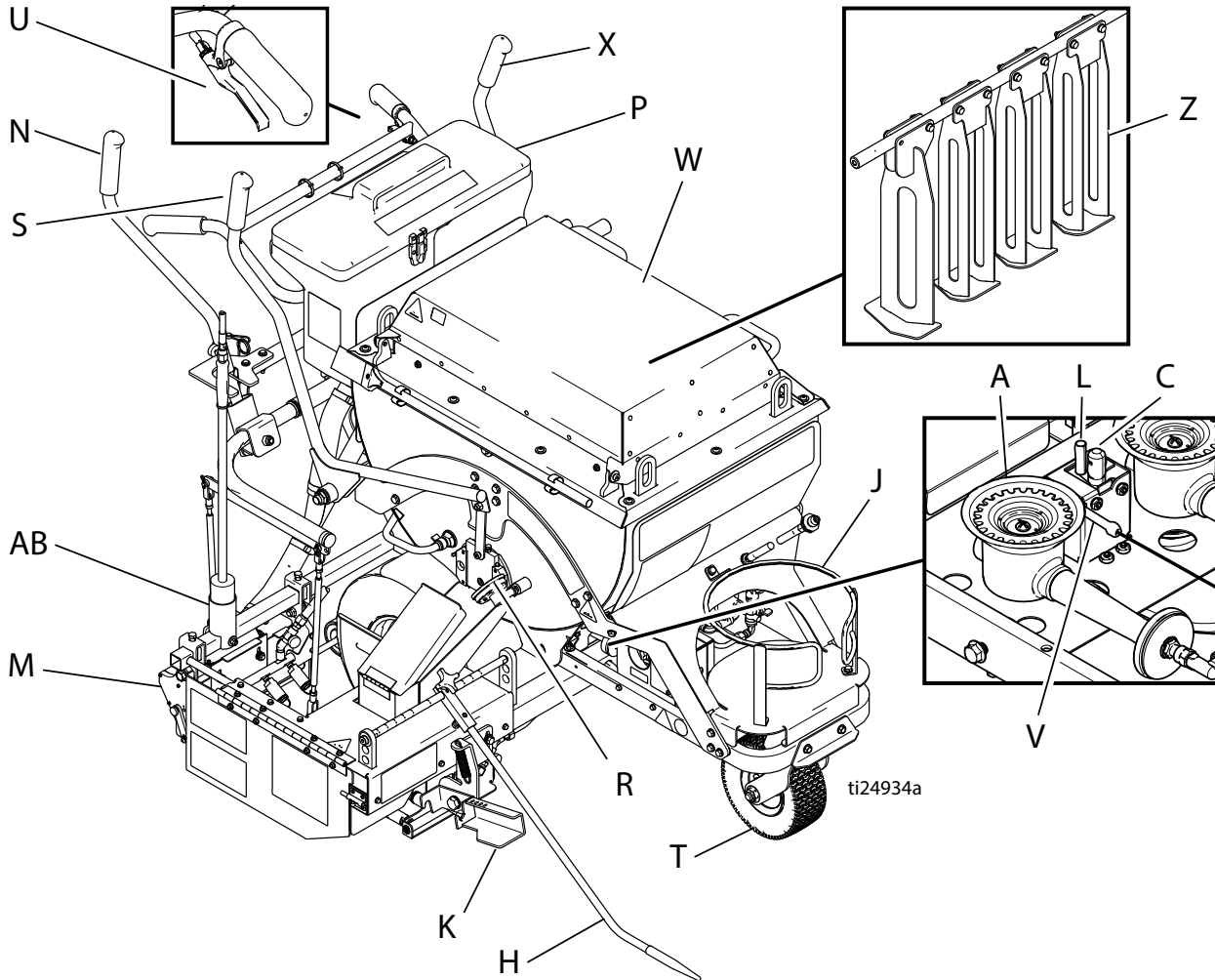

A	Kettle Main Burners (2)
C	Kettle Pilot Burner
H	Line Guide
J	LP Gas Cylinder Holder
K	Screed Box Lever
L	Kettle Thermopile
M	Bead Dispenser Box
N	Screed Box/Bead Dispenser Box Actuator
P	SplitBead Hopper

R	ControlFlow Gate Valve
S	ControlFlow Gate Valve Actuator
T	FatTrack Swivel Tire
U	Front Swivel Wheel Unlock Lever
V	Kettle Pilot Igniter Electrode
W	Access Cover with Latches
X	Agitator Actuator
Z	Agitators
AB	Torch

*LP-Gas supply cylinder not supplied by Graco. LP-Gas supply cylinder must be designed, fabricated, and marked in accordance with specifications and regulators for LP-Gas cylinders at The U.S. Department of Transportation (DOT), The National Standard of Canada, CAN/CSA-B339, Cylinders, Spheres, and Tubes for Transportation of Dangerous Goods, The Transportable Pressure Vessels Regulators 2001 (S1 2001/1426), The Gas Cylinders (Pattern Approval) Regulations 1987 (SI 1987/116)(Pattern Approval Regulations) for EEC-type cylinders under European Directive 84/525/EEC, 84/526/EEC, and 84/527/EEC.



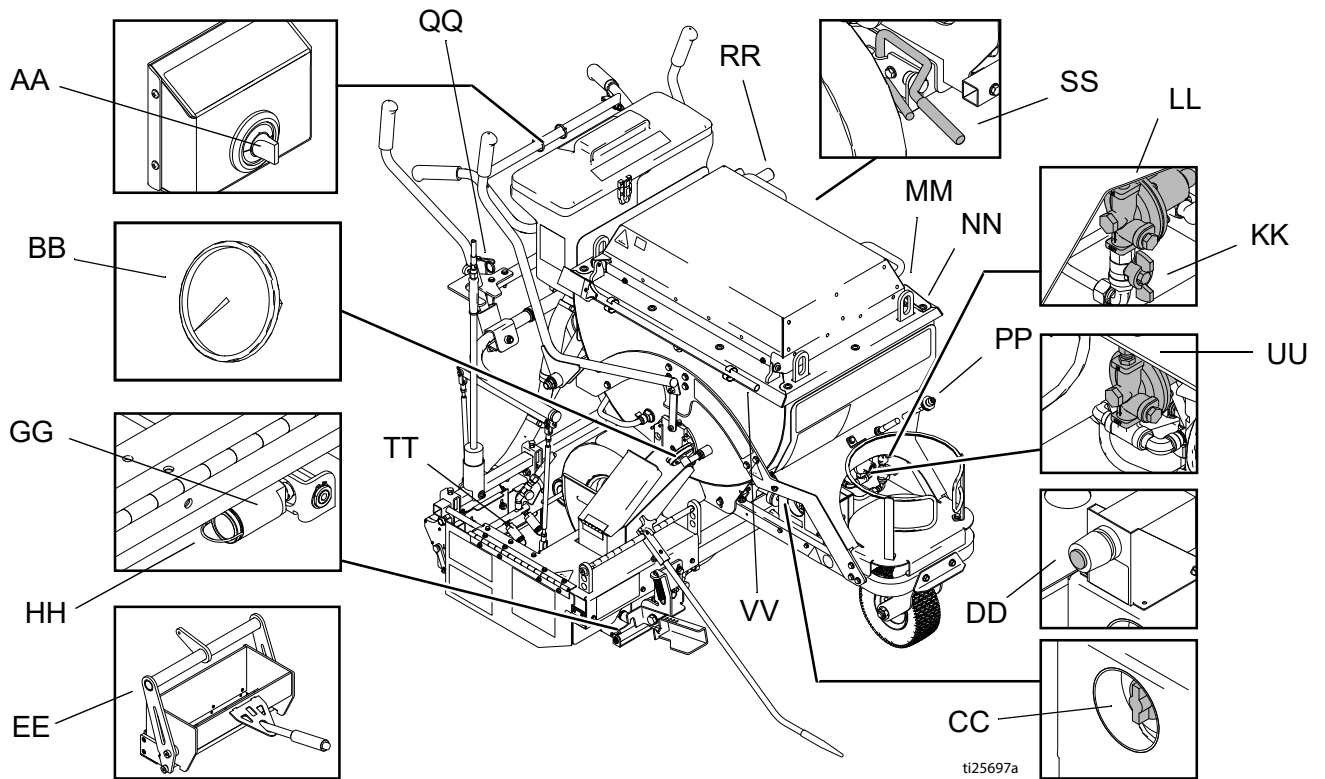

Component Identification - ThermoLazer ProMelt (Continued)



ti25697a

AA	Kettle Temperature Control Knob
BB	Kettle Temperature Indicator
CC	Kettle Gas Safety Valve
DD	Kettle Pilot Burner Igniter
EE	Screed Box (SmartDie II)
GG	Front Screed Box Burners
HH	Flame Indicator
KK	Kettle Burners Manual Shut-Off Valve
LL	Kettle Burner Regulator
MM	Lifting Ring
NN	Lid/Lever Latch
PP	Propane Tank Connector
QQ	Torch Igniter
RR	Agitator Crank
SS	Parking Brake
TT	Rear Screed Box Burners
UU	Screed Box Burners Regulator
VV	Scraper

Important Safety Information

						
<p>If you do not follow these instructions exactly, a fire or explosion may result causing property damage, personal injury or death.</p> <p>Keep gas supply hose away from hot surfaces and flames.</p>						

Use equipment in accordance with state and local ordinances with Storage, Handling and Transportation of Liquid Petroleum Gases, ANSI/NFPA58 or CSA B149.1

If equipment has been in storage, check for insects and insect nests on burners and Venturi tubes.

Use only vertical vapor-withdrawal LP gas cylinders which have been designed, fabricated, tested and marked in accordance with registration of the U.S. Department of Transportation (DOT) or the Standard for Cylinders, Spheres, and Tubes for the Transportation of Dangerous Goods CAN/CSA-B337, The Transportable Pressure Vessels Regulators 2001 (S1 2001/1426), The Gas Cylinders (Pattern Approval) Regulations 1987 (SI 1987/116)(Pattern Approval Regulations) for EEC-type cylinders (under European Directive 84/525/EEC, 84/526/EEC, and 84/527/EEC. Use only 20 lb to 30 lb (9.07 kg to 13.6 kg) LP-Gas cylinders.

LP-Gas cylinder to be used only in vertical upright position as noted on agency approved LP-Gas cylinder for proper vapor withdrawal.

Check gas supply hose connection to LP-Gas cylinder. Make sure fitting is free of debris before connecting to tank. Make sure gas connection is screwed completely on and is free of leaks.



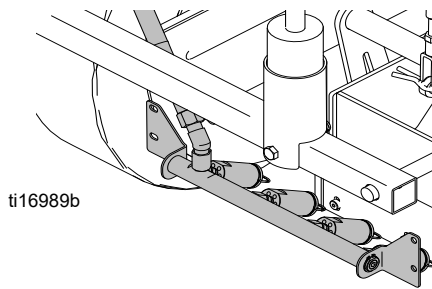
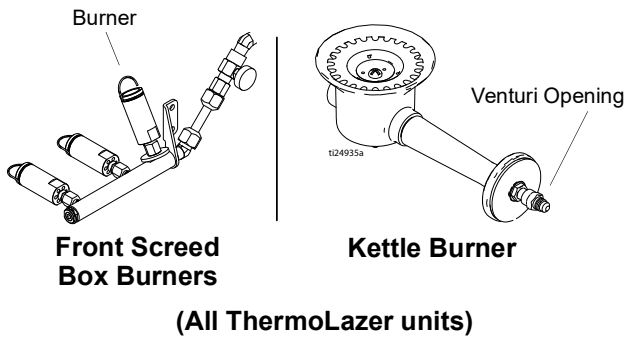

NOTE: The LP gas tanked is equipped with a POL gas fitting. If a different sized fitting is needed, see your local LP gas equipment supplier.

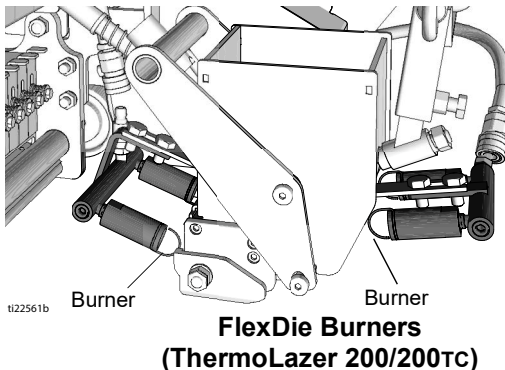
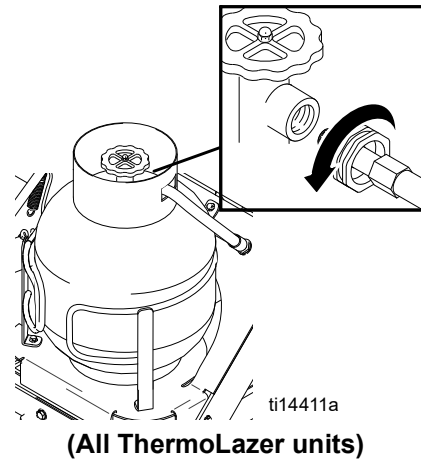

Rear Sreod Box Burners
(ThermoLazer 300Tc/ProMelt)



Important Safety Information

						
<p>If you do not follow these instructions exactly, a fire or explosion may result causing property damage, personal injury or death.</p>						

BEFORE LIGHTING: Smell all around the working area for gas. Be sure to smell next to the ground because propane is heavier than air and will settle on the ground.

DAILY: Check for gas leaks. Use mild soap and water solution or other approved method. Apply solution to all gas lines and fittings then watch for gas bubbles.

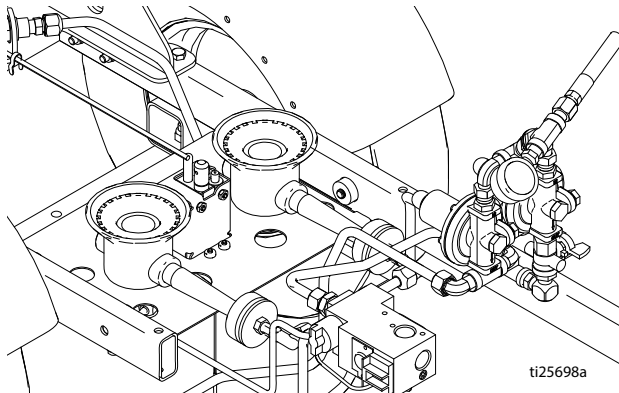

ti16842b

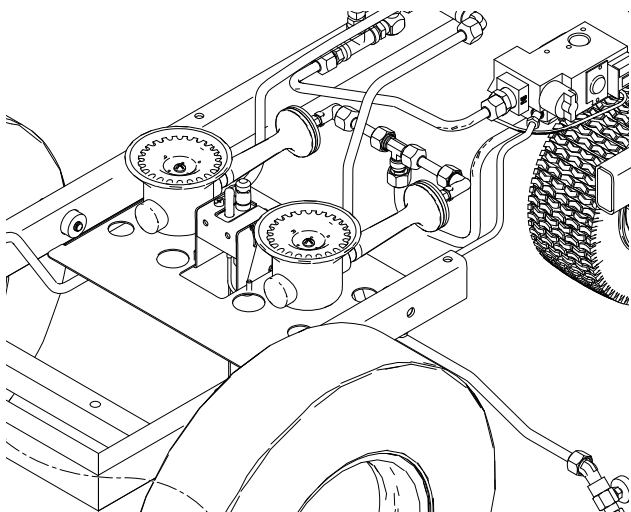

ti16832b

ThermoLazer 300TC/ProMelt shown above

Front Screenshot Burners and Rear Screenshot Box Burners will need to be ignited to test gas lines and fitting downstream of flame adjusting valve.

NOTE: Kettle burners will need to be ignited to test gas lines and fittings downstream of gas safety valves (CC). Ignite burners and torch only after thoroughly checking gas line and fittings.

WHAT TO DO IF YOU SMELL GAS OR FIND GAS BUBBLES:

- Evacuate all unqualified personnel from area
- Do not try to ignite any burner
- Do not strike a flame
- Do not use electric fans to remove gas from area
- Do not touch any electric switch and do not use any phone
- If leak is from a gas fitting, tighten fitting until leak stops
- If leak is from a gas line, shut off at LP-gas cylinder and replace gas line
- Immediately call your gas supplier from a remote phone. Follow gas supplier's instructions.
- If leak can not be stopped by shutting off LP-gas cylinder shut-off valve, immediately call your gas supplier from a remote phone. Follow gas supplier's instructions.
- If you cannot reach your gas supplier call the fire department

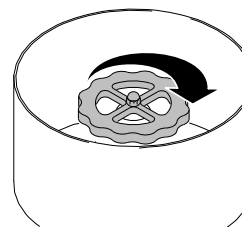





ti14128a

Use only your hand to push in or turn the kettle gas safety valve (CC). Never use tools. If the knob will not push in or turn by hand, do not try to repair it; call a qualified service technician. Attempted repair or force may result in a fire or explosion.







Do not use this equipment if any part has been under water. Immediately call a qualified service technician to inspect equipment and all components. Replace defective parts only with approved manufactured parts.

Important Safety Information

Before attempting to start equipment:

						
---	---	---	---	--	--	--



If you do not follow these instructions exactly, a fire or explosion may result causing property damage, personal injury or death.

						
---	---	---	---	---	---	---

All surfaces are capable of becoming extremely hot. Be sure to always wear heat-resistant gloves and other protective equipment rated for 500° F (260° C). Material and unit are very hot 350° - 500° F (177° C - 260° C). Never exceed material maximum temperature rating.



Hot molten plastic will burn skin. Do not attempt to remove from skin. Cool under running water and seek medical attention.

See MSDS for Thermoplastic Traffic Marking Compound.

						
---	---	---	--	--	--	--

FIRE AND EXPLOSION HAZARD

If using this unit in conjunction with LineDriver[®], do not fill gasoline tank while burners are ignited. Allow equipment to completely cool before refueling.

						
---	---	--	--	--	--	--

INHALATION HAZARD

Melting thermoplastic produces toxic fumes. Avoid prolonged inhalation of fumes.

DAILY: Check all gas lines and fittings for gas leaks.

DAILY: Check gas supply hose for wear, abrasions, cuts or leaks. Replace only with hoses recommended by Graco.

Check gas supply hose connection to LP-gas cylinder. Make sure fitting is free of debris before connecting to tank. Make sure gas connection is screwed completely on and is free of leaks.

Check to ensure that the following are closed:

- LP Gas Tank manual shut-off valve
- ControlFlow gate valve
- Front screed box burner flame adjusting valve
- Torch/flame adjusting valve
- Screed box burner flame adjusting valve (24H622 and 24H624 only)
- Kettle gas burner manual shut-off valve
- Kettle gas safety valve
- Kettle temperature control knob (turn to "OFF")

Check to make sure exhaust openings on kettle are not obstructed.

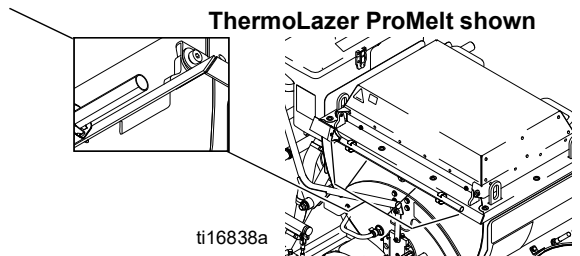
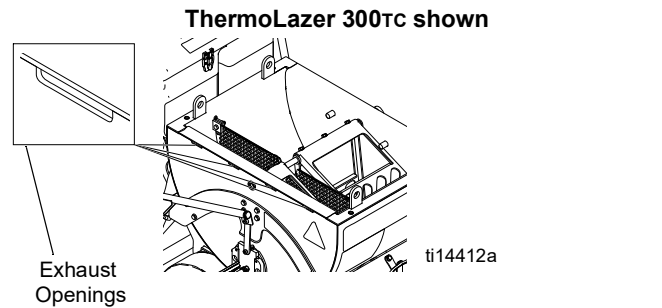

Check to make sure combustion air supply openings on kettle are not obstructed.

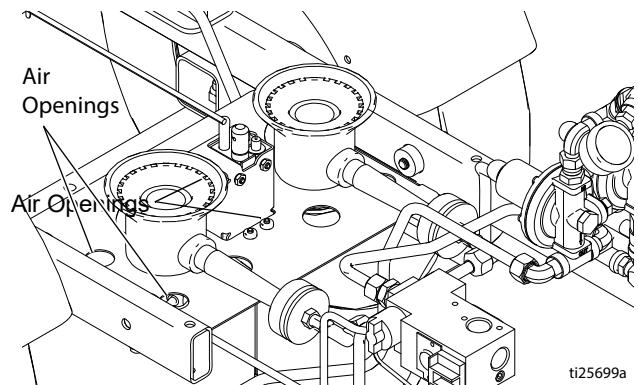

Lighting Instructions

Lighting Kettle Burners

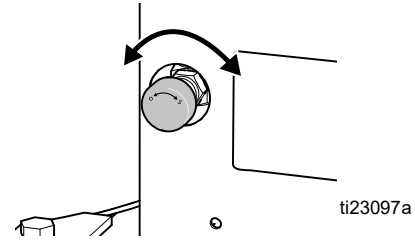
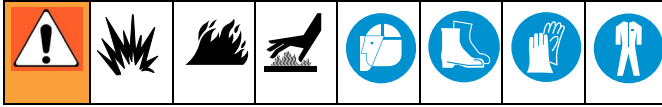

NOTE: Read Important Safety Information, page 14-16.

ThermoLazer 200

1. Open kettle door to view burner.

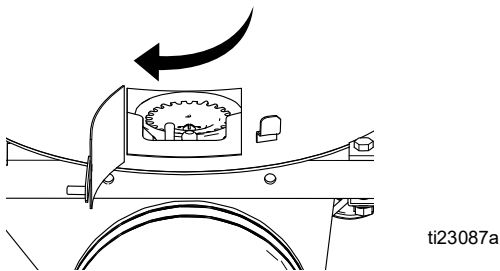

2. Open propane tank valve.

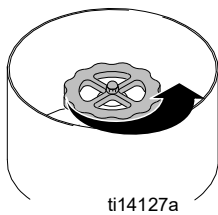

3. Open kettle temperature control knob (AA).

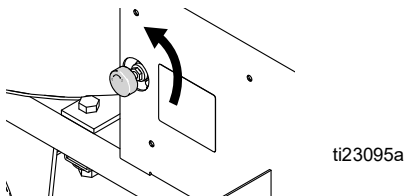

4. Light kettle burner with torch.

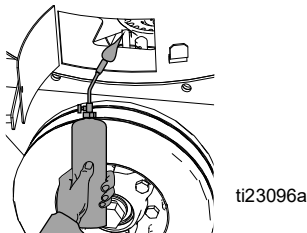

5. Regulate kettle flame as desired with kettle temperature control knob (AA).

--	--	--	--	--	--	--

FIRE AND EXPLOSION HAZARD
 If pilot ignites without depressing the gas safety valve knob, replace gas safety valve. If gas safety valve knob does not pop back after releasing in pilot position, STOP and replace gas safety valve. Shut off gas at propane tank before replacing valve.

6. Turn gas safety valve knob to "ON".
7. Turn temperature to 250° F (121° C) and observe that main burners have ignited. Turn kettle temperature control back to "OFF" and observe that main burners shut off.

--	--	--	--	--	--	--

FIRE AND EXPLOSION HAZARD
 If main burners do not ignite or shut off when rotating temperature control knob, STOP. Shut off gas at the propane tank. Follow diagnostic procedure in Repair manual.

8. Turn temperature control to desired setting.

ThermoLazer 200TC

1. Open kettle door.

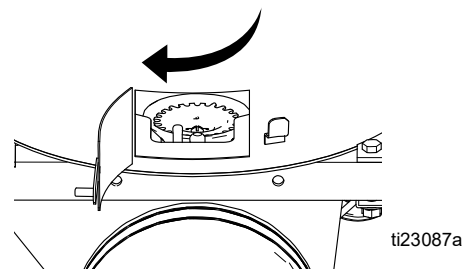

- Open propane tank valve.

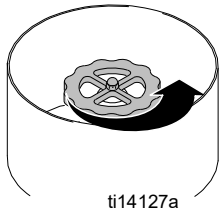

- Turn gas safety valve (CC) to "PILOT" and push in.

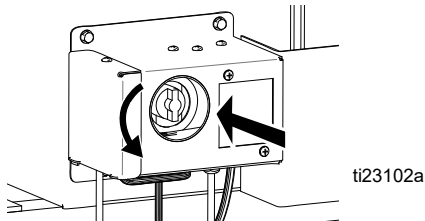

- Light kettle burner with torch.

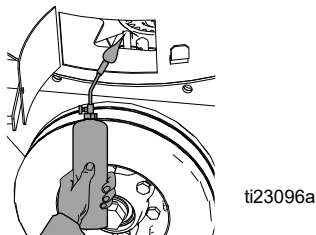

- Continue to push in gas safety valve (CC) for approximately 1 minute. If pilot goes out, repeat steps 3-5 after 10 minutes.

FIRE AND EXPLOSION HAZARD						
If pilot ignites without depressing the gas safety valve knob, replace gas safety valve. If gas safety valve knob does not pop back after releasing in pilot position, STOP and replace gas safety valve. Shut off gas at propane tank before replacing valve.						

- Turn gas safety valve knob to "ON".
- Turn temperature to 250° F (121° C) and observe that main burners have ignited. Turn kettle temperature control knob back to "OFF" and observe that main burners shut off.

FIRE AND EXPLOSION HAZARD						
If main burners do not ignite or shut off when rotating temperature control knob, STOP. Shut off gas at the propane tank. Follow diagnostic procedure in Repair manual.						

- Turn temperature control to desired setting.

ThermoLazer 300TC/ProMelt

- Turn temperature control knob (AA) to "OFF".

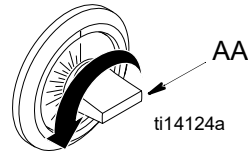

- Turn kettle gas safety valve (CC) to "OFF".

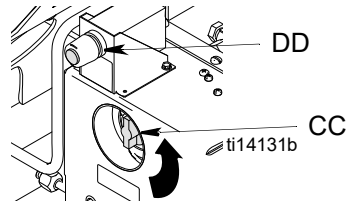

- Open kettle burner view port. (Not all models have a view port.)

Kettle Burner

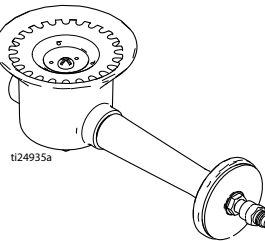

- Open manual shut-off valve on propane tank located at front of unit; open kettle manual shut-off valve (KK) below kettle and behind propane tank.

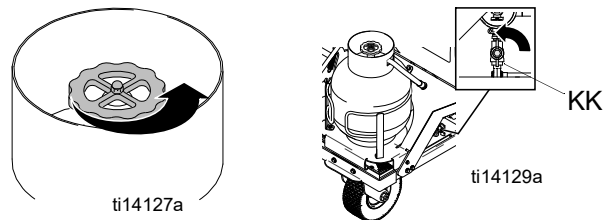

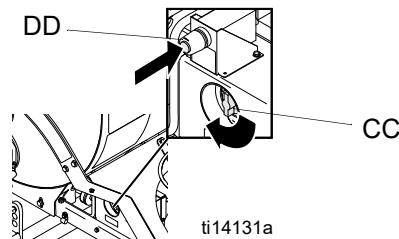

ThermoLazer 300TC shown

- Turn gas safety valve (CC) to "PILOT".





- Push in gas safety valve knob.
- Push kettle pilot burner igniter (DD) until pilot ignites.

- Continue to push in gas safety valve (CC) for approximately 1 minute. If pilot goes out, repeat steps 4-6 after 10 minutes.

						
FIRE AND EXPLOSION HAZARD						
If pilot ignites without depressing the gas safety valve knob, replace gas safety valve. If gas safety valve knob does not pop back after releasing in pilot position, STOP and replace gas safety valve. Shut off gas at propane tank before replacing valve.						

- Turn gas safety valve knob to "ON".
- Turn temperature to 250° F (121° C) and observe that main burners have ignited. Turn kettle temperature control back to "OFF" and observe that main burners shut off.

						
FIRE AND EXPLOSION HAZARD						
If main burners do not ignite or shut off when rotating temperature control knob, STOP. Shut off gas at the propane tank. Follow diagnostic procedure in Repair manual.						

- Turn temperature control to desired setting.

Shutting Off Burner

ThermoLazer 200

- Close kettle temperature control knob.

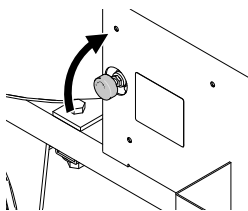

ti23100a

- Close kettle manual shut-off valve (KK) when finished heating with kettle burners. Close manual shut-off valve on propane tank when finished melting and heating thermoplastic material.

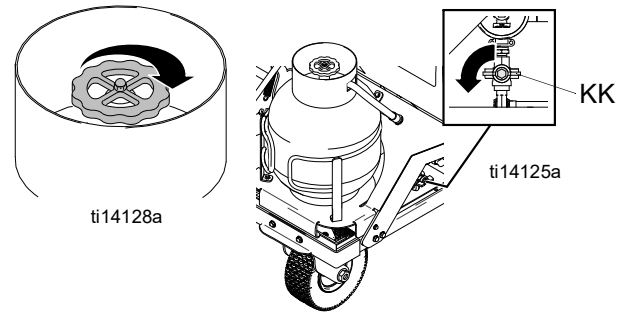

NOTE: The kettle gas burner can be lit manually with a small torch (for example: DOT 39 NRC 228/286 Cylinder with #3 torch tip) if the battery powered pulse igniter fails to light the pilot.

ThermoLazer 200TC

- Turn gas safety valve to "OFF".

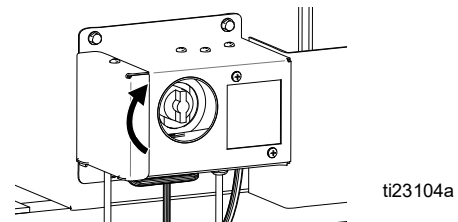

- Close kettle manual shut-off valve (KK) when finished heating with kettle burners. Close manual shut-off valve on propane tank when finished melting and heating thermoplastic material.

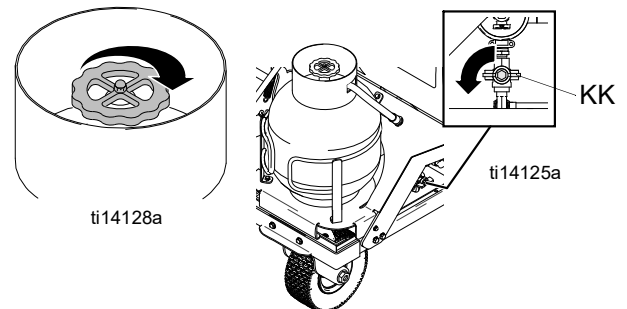

NOTE: The kettle gas burner can be lit manually with a small torch (for example: DOT 39 NRC 228/286 Cylinder with #3 torch tip) if the battery powered pulse igniter fails to light the pilot.

ThermoLazer 300TC/ProMelt

1. Turn gas safety valve to "OFF".
2. Close kettle manual shut-off valve (KK) when finished heating with kettle burners. Close manual shut-off valve on propane tank when finished melting and heating thermoplastic material.

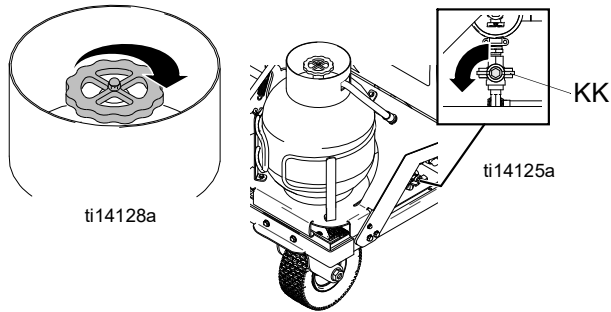

NOTE: The kettle gas burner can be lit manually with a small torch (for example: DOT 39 NRC 228/286 Cylinder with #3 torch tip) if the battery powered pulse ignitor fails to light the pilot.

Torch Lighting Instructions

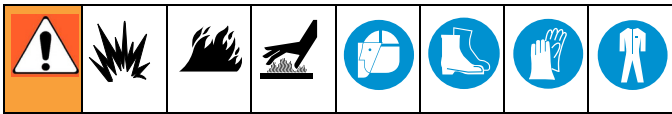

1. Open manual shut-off valve on propane tank located at front of unit.

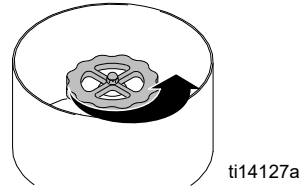

2. Remove external torch from holder.

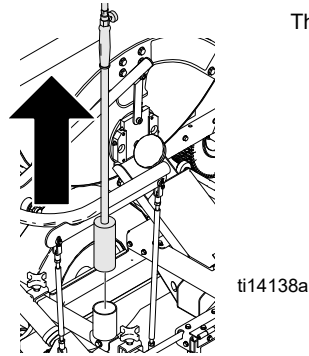

3. Slowly open torch flame adjusting valve and use striker to ignite flame.

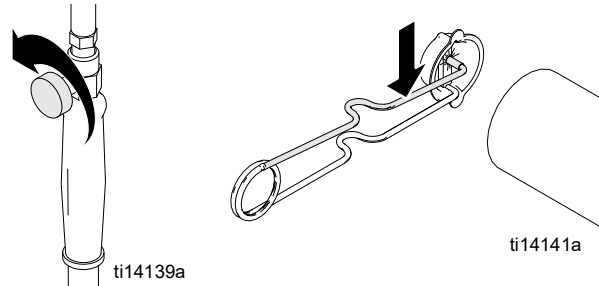

4. Adjust flame to desired length.

Shutting Off Torch

1. Fully close torch flame adjusting valve.

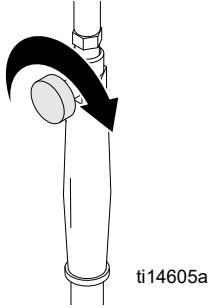

2. Close manual shut-off valve on propane tank when finished melting and heating thermoplastic material.

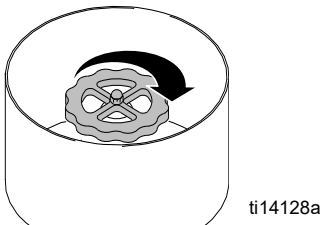

Front Screed Box Burner Lighting Instructions

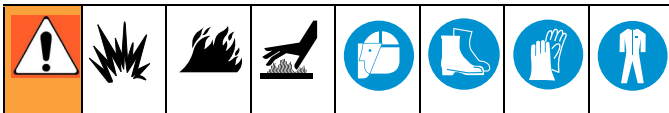

Read **Important Safety Information**, page 14-16.

1. Make sure screed box burners flame adjusting valve is turned OFF.
2. Open manual shut-off valve on propane tank located at front of unit.
3. Light torch (see **Torch Lighting Instructions**, page 20).
4. Open screed box access door.

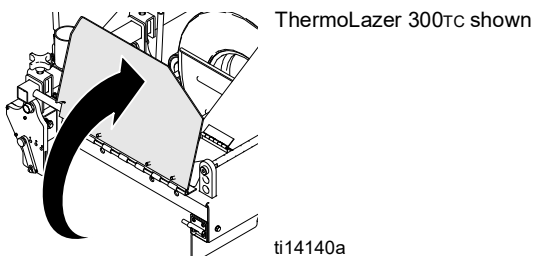

5. Slowly open screed box burners flame adjusting valve.

ThermoLazer 300TC/ProMelt

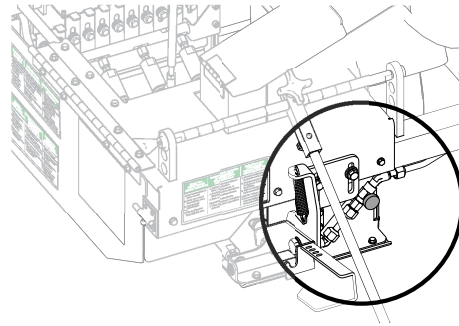

ThermoLazer 200/200TC

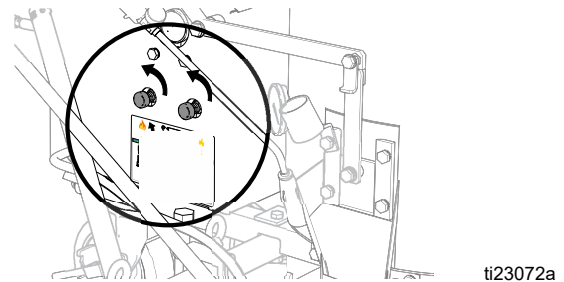

6. Place torch at end of screed box burners to ignite and use screed box burners flame adjusting valve to adjust to desired flame.

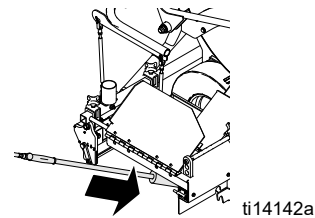

NOTICE

If material begins to smoke or become discolored, turn screed box burners down or off to prevent material from burning.

7. Visually inspect to make sure flame indicators are glowing.

Shutting Off Burners

1. Fully close screed box burners flame adjusting valve.
2. Close manual shut-off valve on propane tank.

Rear Screed Box Burner Lighting Instructions (ThermoLazer 300Tc/ProMelt)

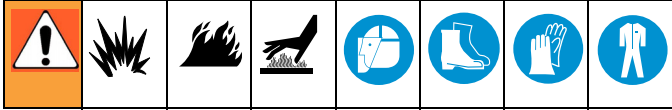

Read **Important Safety Information**, page 14-16.

1. Make sure screed box burners flame adjusting valve is turned OFF.
2. Open manual shut-off valve on propane tank located at front of unit.
3. Light torch (see **Torch Lighting Instructions**, page 20).
4. Slowly open screed box burners flame adjusting valve.

5. Place torch at end of screed box burners to ignite and use screed box burners flame adjusting valve to adjust to desired flame.

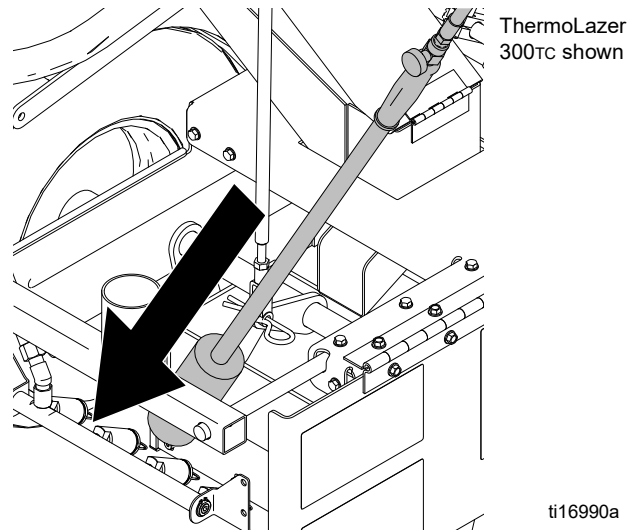

NOTICE

If material begins to smoke or become discolored, turn screed box burners down or off to prevent material from burning.

6. Visually inspect to make sure flame indicators are glowing.

Shutting Off Burners

1. Fully close screed box burners flame adjusting valve.
2. Close manual shut-off valve on propane tank.

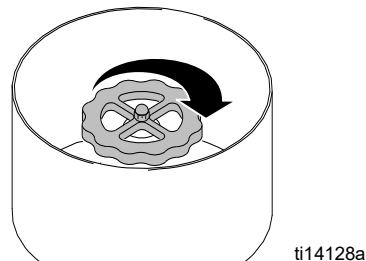

Screed Box ThermoLazer 200/200TC (FlexDie)

Installation

<p>Use extreme caution when installing and removing screed box. Expect all equipment components and material to be extremely hot. See MSDS for Thermo-plastic Traffic Marking Compound.</p>					

1. Shut off screed box burners.

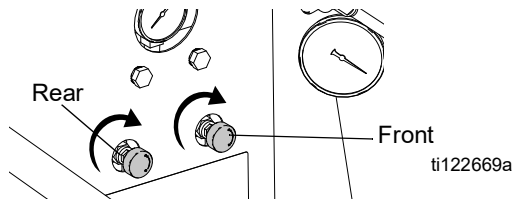

2. Remove bolt (a) and slide FlexDie into place.

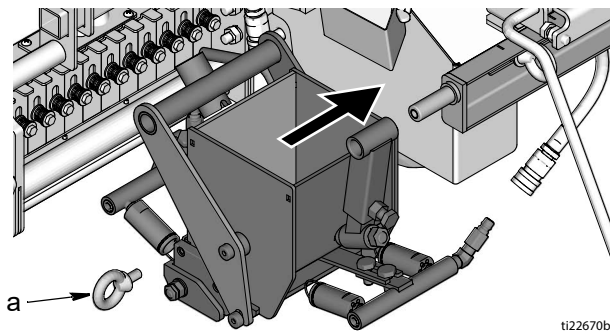

3. Replace and tighten bolt (a).

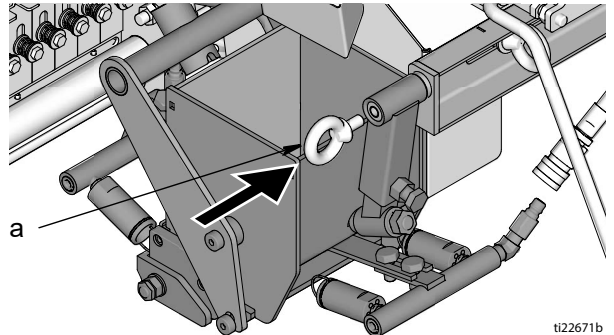

4. Attach spring loaded handle (Z) to the yoke (31) and turn 90 degrees to lock into place.

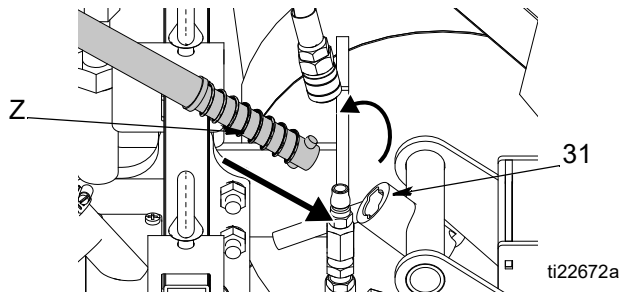

5. Attach both gas hoses to quick release couplings (10).

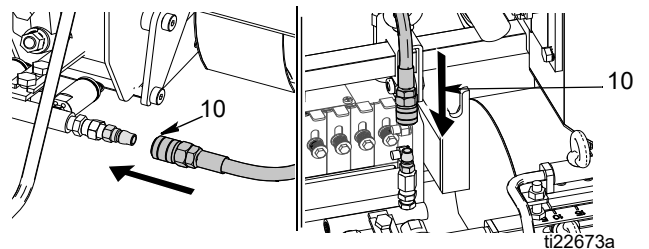

6. Re-light screed box burners as required (see **Screed Box Burner Lighting**, page 21).

Removal

1. Shut off screed box burners.

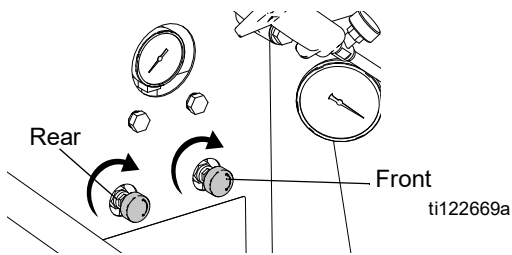

2. Remove the two gas hoses from quick release couplings (10).

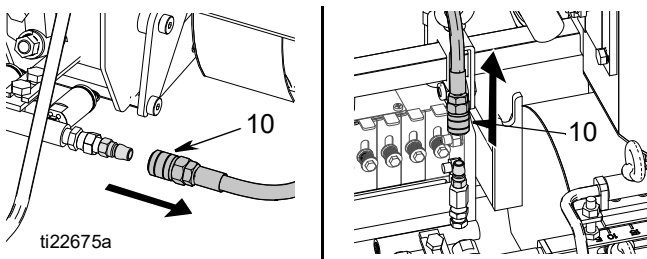

3. Push in and turn spring loaded handle 90 degrees and remove from yoke (31).

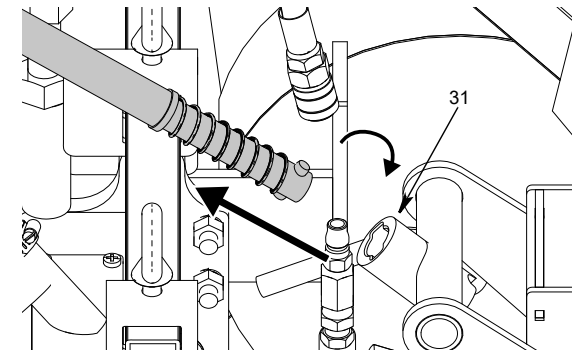

4. Remove bolt and slide FlexDie box off.

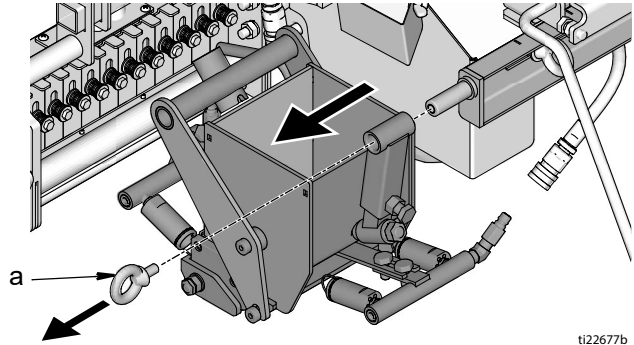

--	--	--	--	--	--

BURN HAZARD
 Make sure to use two hands when picking up screed box. Place one hand on yoke and one hand on rod.

ti17047b

Do **NOT** pick up screed box with one hand and/or at one location.

ti17048b

Adjustments

For optimum delivery of the thermoplastic material, make sure the screed box is aligned to center on kettle trough.

1. Loosen two bolts (c) on mounting bracket.

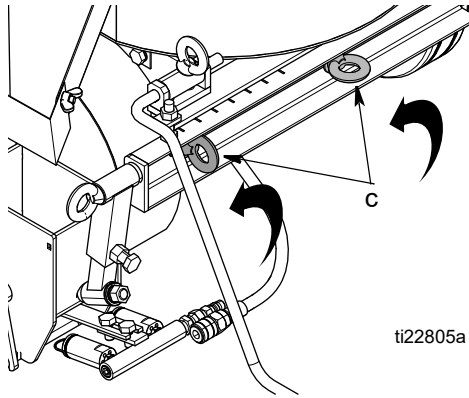

2. Slide mount left or right until edge of the frame is aligned with desired markings on bracket.

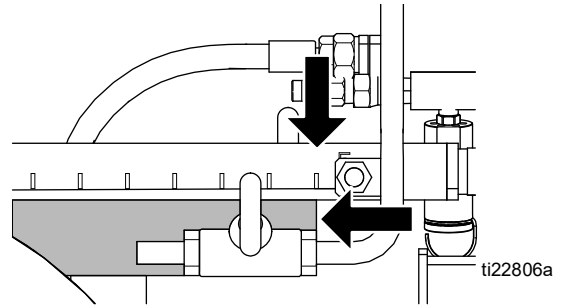

3. Tighten bolts (c) on screed box mounting bracket.

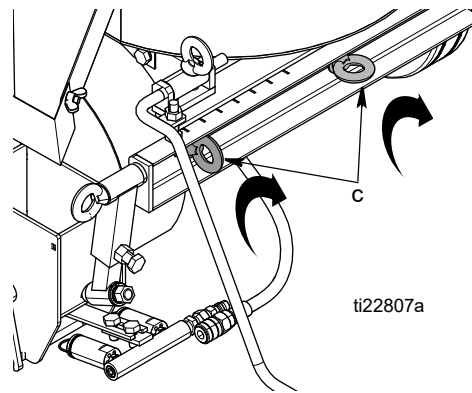

Screed Box ThermoLazer 300TC/ProMelt (SmartDie II)

Installation

<p>Use extreme caution when installing and removing screed box. Expect all equipment components and material to be extremely hot. See MSDS for Thermo-plastic Traffic Marking Compound.</p>					

1. Shut off screed box burners.

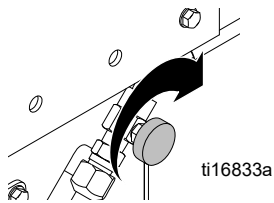

2. Slide screed box under screed shroud and press down on screed box lever.

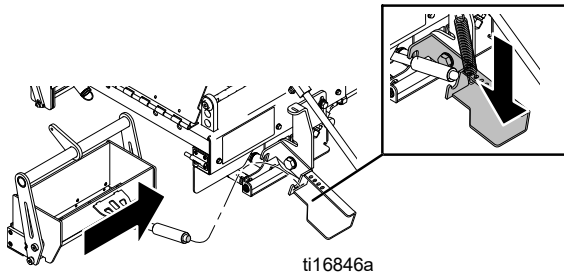

3. Engage screed box rod into screed box lever.

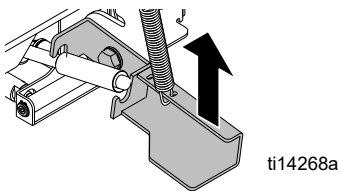

4. Align hole of rod clevis with connecting hole in screed box yoke and install hairpin cotter pin.

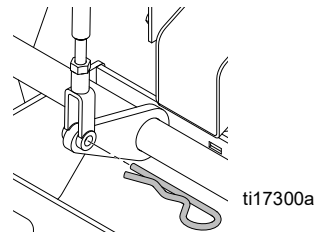

5. Close and lock screed shroud door.
6. Re-light screed box burners as required (see **Screed Box Burner Lighting**, page 21).

Removal

1. Shut off screed box burners.

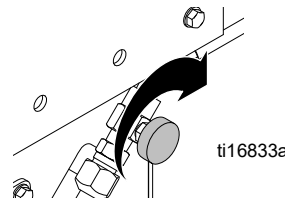

2. Remove hairpin cotter pin connecting screed box to rod clevis.

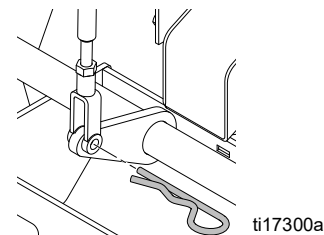

3. Press down screed box lever.

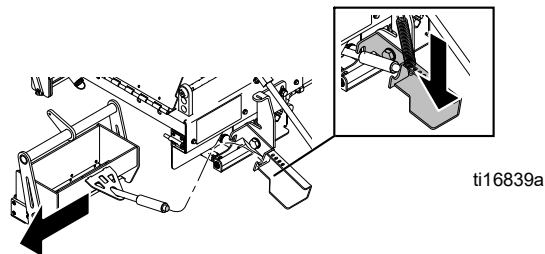

4. Disengage screed box rod from screed box lever and carefully remove screed box.

--	--	--	--	--	--

BURN HAZARD
 Make sure to use two hands when picking up screed box. Place one hand on yoke and one hand on rod.

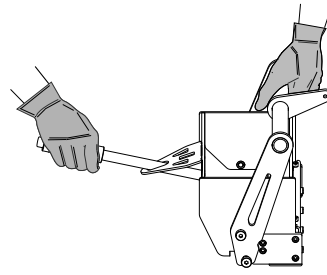

ti17047b

Do **NOT** pick up screed box with one hand and/or at one location.

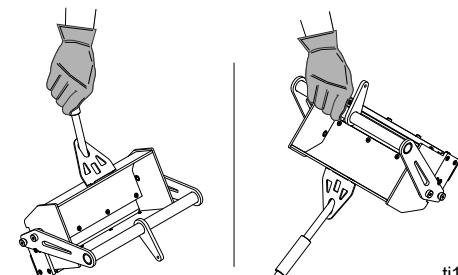

ti17048b

Adjustment

The height and angle of the screed box can be adjusted to ensure a solid line of material on any surface. For optimum delivery of thermoplastic material, make sure the screed box runner is adjusted as described.

1. Loosen two bolts on screed box mounting bracket.

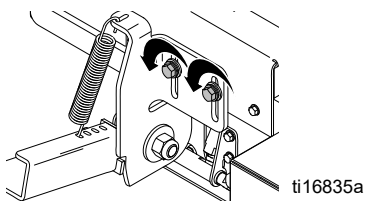

2. Slide mount down until leading box edge of screed box runner is just off of the ground surface. For best performance, raise leading edge .020 in. (0.5 mm) off ground surface. Scraper blade may be used to set this depth.

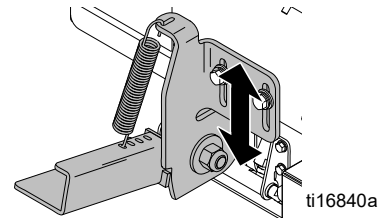

Screed Box

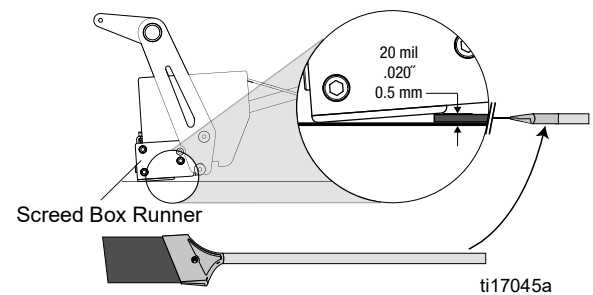

3. Tighten bolts on screed box mounting bracket.

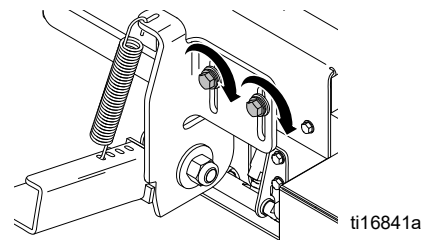

4. Spring position may be moved to a different hole. The farthest holes provide greatest force to close the gate.

Screed Box Line Thickness Adjustment

(All ThermoLazer units)

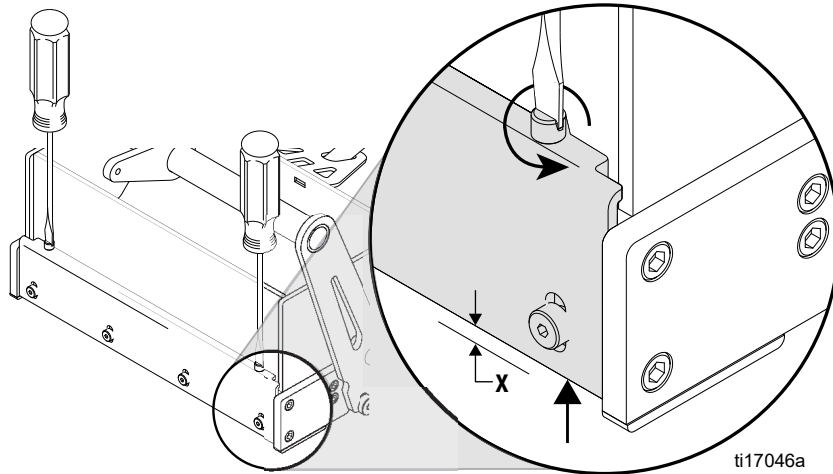

X ↑	↻
mil	# Turns
30	0.6
60	1.2
90	1.8
120	2.4
150	3.0
mm	# Turns
0.5	0.4
1.0	0.8
1.5	1.2
2.0	1.6

NOTE: 1/4 turn will change line thickness by .013 in. (0.3 mm). Turn the line adjustment screw clockwise for a thinner line, or counterclockwise for a thicker line.

Typical settings on pavement: 0.060 - 0.125 in. (0.153 - 0.318 cm).

Typical settings on metal stencil: Flush - 0.0 in. (0.0 cm).

1. Move screed box actuator to middle position. Make sure screed box is closed and resting on the ground. **NOTE:** All screed boxes are initially set at 90 mil (1.8 mm). Adjustment may be required before first use.
2. Use a flat screwdriver to turn line adjustment screws clockwise so that line thickness is zero.
3. Turn line adjustment screws counter-clockwise until desired line thickness is reached.
4. Measure line thickness after applying thermoplastic and adjust as necessary.

Preparing ThermoLazer 200/200TC/300TC for Application

BURN HAZARD							
Keep all access covers closed and latched when equipment is in use.							
Always secure ThermoLazer by chocking wheels when adding thermoplastic.							

1. Secure the unit by chocking wheels and applying parking brake.
2. Make sure kettle burners and screed box burners are lit.
3. Allow kettle to heat up before adding material. If kettle is completely empty, allow kettle to reach 300° - 350° F (149° - 177° C) before adding material. If kettle has material, allow material to reach 380° F (193° C) before adding material.
4. Secure ThermoLazer by chocking wheels.

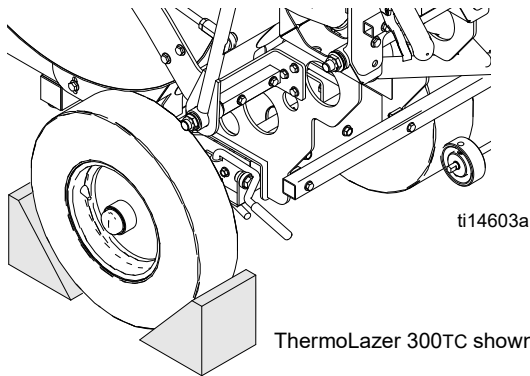

5. Add thermoplastic material to kettle.

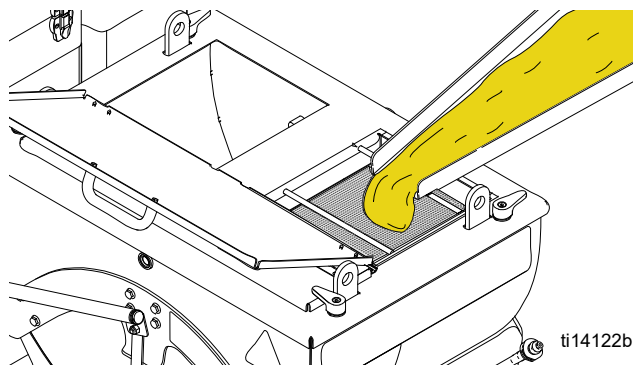

6. Move Gate Valve Actuator (S) to raised position and fill screed box with melted thermoplastic material.

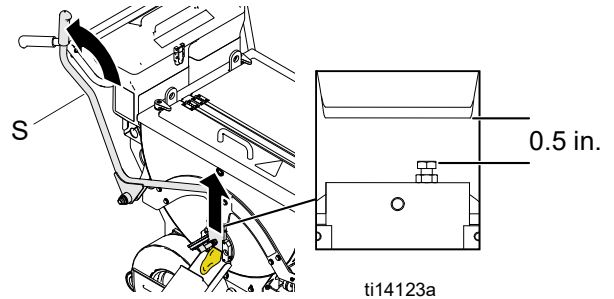

NOTE: The material gate is adjustable. The gate is factory set at a 0.5 in. (1.3 cm) gap. You can increase this gap for more material flow or decrease the gap for less material flow.

7. Do not overfill material in kettle. Overfill would be material higher than 5 in. (13 cm) below top of kettle.

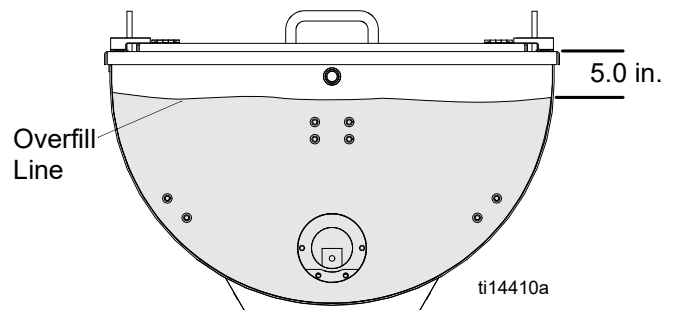

8. Close and latch cover access doors when applying thermoplastic.
9. Avoid bumping or impacting ThermoLazer to prevent spillage or splashing of hot material.

Preparing ThermoLazer ProMelt for Application

--	--	--	--	--	--	--	--

BURN HAZARD
 Keep all access covers closed and latched when equipment is in use.

Always secure the unit by chocking wheels when adding thermoplastic.

1. Secure the unit by chocking wheels and applying parking brake.

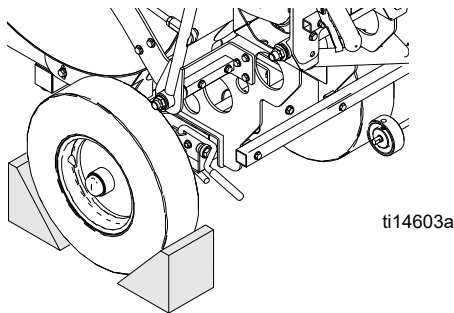

2. Make sure kettle burners and screed box burners are lit.
3. Set Kettle Temperature Control to maximum temperature recommended by thermoplastic manufacturer.

NOTE: If the kettle is empty do not allow the kettle to heat for more than five minutes before adding thermoplastic.
4. If the kettle has 50 lb or more of thermoplastic already inside, allow the kettle to reach maximum melting temperature recommended by thermoplastic manufacturer.
5. Unlatch kettle cover, raise cover, rotate agitator crank to 9 o'clock position and hold at this position using the cover latch.

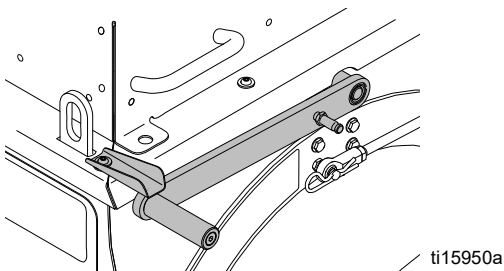

6. Load bag of thermoplastic directly on kettle heat exchanger. Close cover with cover latches.

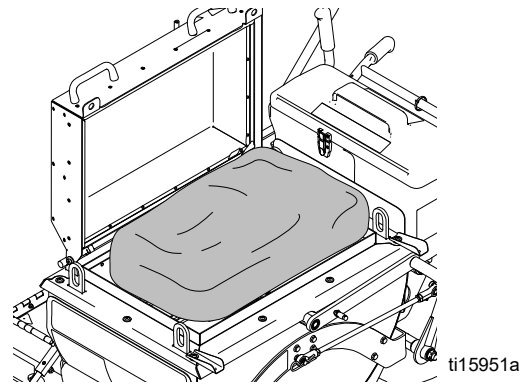

7. Agitate thermoplastic until material is completely melted. To get best agitation results, use the agitator crank. Use the link-connected agitator actuator setup to agitate melted thermoplastic.

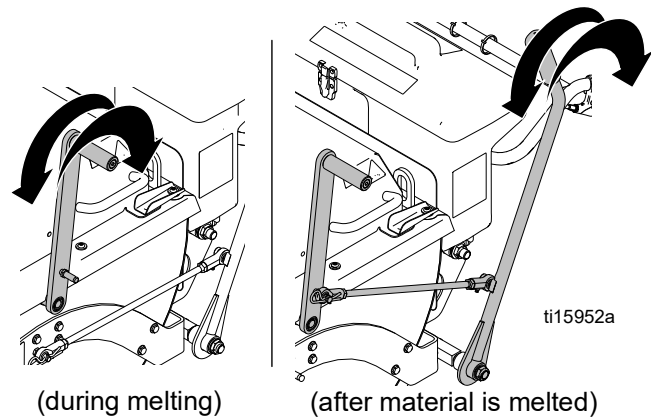

8. Repeat steps 5 - 7 until kettle is filled with melted thermoplastic.
9. Once material has been completely melted, lower temperature to recommended material application temperature to prevent material from overheating.
10. Start the box burner three minutes before filling screed box with material.
11. Use torch to heat screed box and chute to application temperature if screed box and chute temperatures are low.
12. Release parking break and remove wheel chocks.

13. Move ControlFlow Gate Valve Lever (S) to raised position and fill screed box with melted thermoplastic material.

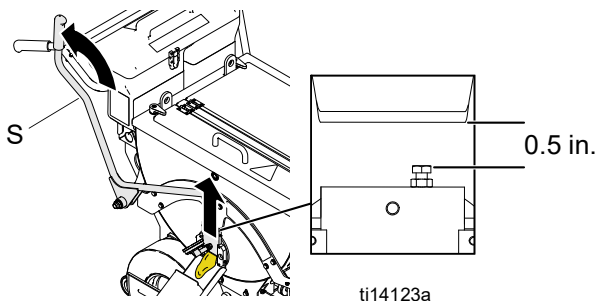

NOTE: The material gate is adjustable. The gate is factory set at a 0.5 in. (1.3 cm) gap. You can increase this gap for more material flow or decrease the gap for less material flow.

14. Do not overfill material in kettle. Overfill would be material higher than 5 in. (13 cm) below top of kettle.

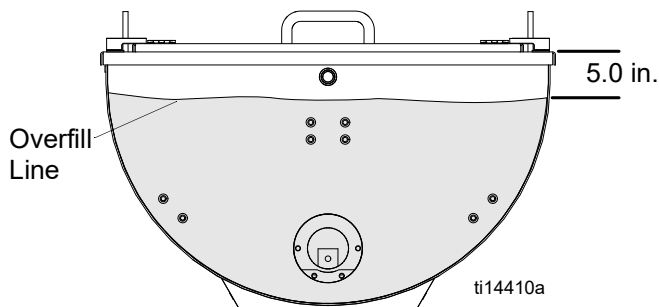

15. Avoid bumping or impacting the unit to prevent spillage or splashing of hot material.

ProMelt Overheating Protection

This unit has a built-in protective device to prevent damage from overheating. The kettle burners may automatically shut down if excessive temperatures are reached. If this happens, allow the unit to cool down for 20-30 minutes or until main kettle burners (2) reignite and resume operation.

Bead Dispenser Box (All ThermoLazer units)

The Bead Dispenser Box has multiple doors which can be opened and closed to allow beads to be dispensed at desired width patterns.

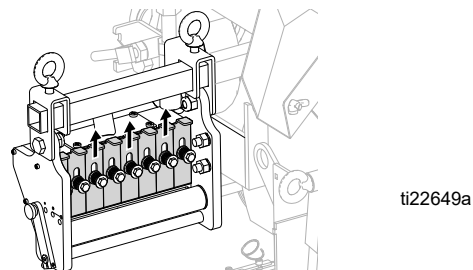

Bead flow rate can be adjusted using the Bead Flow Rate Lever on the outside of the Bead Dispenser Box.

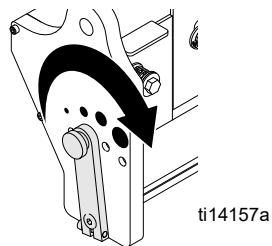

Adding Beads to SplitBead Hopper

Single Bead Application (ThermoLazer 200/200TC)

1. Open SplitBead hopper door.
2. Fill hopper with beads.

Close and lock hopper door. Do not allow beads to remain in hopper, hoses or bead dispenser for an extended period of time. Beads will absorb moisture, bond to adjacent beads and harden.

Single Bead Application (ThermoLazer 300TC/ProMelt)

1. Unlock and open SplitBead hopper door.
2. Fill both sides of hopper with beads.

Close and lock hopper door. Do not allow beads to remain in hopper, hoses or bead dispenser for an extended period of time. Beads will absorb moisture, bond to adjacent beads and harden.

Double Bead Application (ThermoLazer 300TC/ProMelt) (Requires Installation of Double Bead Kit 24C528)

1. Fill element beads on left side (smaller chamber).
2. Fill glass beads on right side (larger chamber).

Close and lock hopper door. Do not allow beads to remain in hopper, hoses or bead dispenser for an extended period of time. Beads will absorb moisture, bond to adjacent beads and harden.

Bead Dispenser Engagement Wheel

To properly dispense beads, drive wheel (27) must be in direct contact with tire (89). If drive wheel (27) becomes loose and/or starts to slip, use allen wrench to tighten set screw (211).

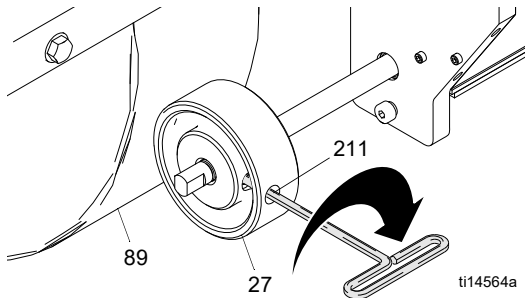

Applying Material to a Surface

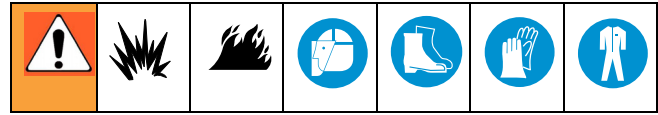

1. Position unit over target area and push forward in a straight line until front wheel locks into centered position (a slight click will be heard when wheel is engaged). Use Line Guide to help guide the unit.
2. Pull unit back to start of target area and move screed box into position.
3. Pull thermoplastic ControlFlow Gate Valve Actuator (S) and fill screed box with melted material.
4. Open valve actuator gate and fill screed box to a level 1.5 in. (3.8 cm) from top.
5. Push screed box/bead dispenser box actuator (N) forward to deploy screed box and engage bead dispense wheel.
6. Push the unit forward with screed box deployed and bead dispenser wheel engaged to apply material.

For examples of correct and incorrect material application, see **Troubleshooting** section in Repair manual.

Shutting Down

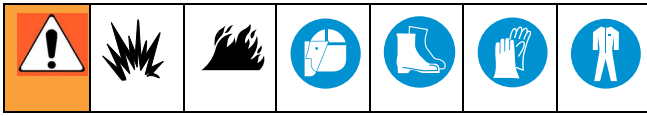

1. Turn kettle gas safety valve (CC) to "OFF" position.

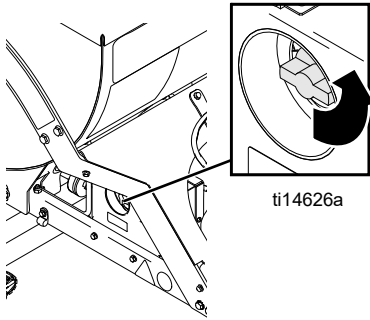

2. Turn temperature control knob (AA) to "OFF".

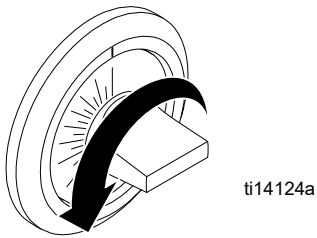

3. Fully close front and rear screed burner flow flame adjusting valve OFF.

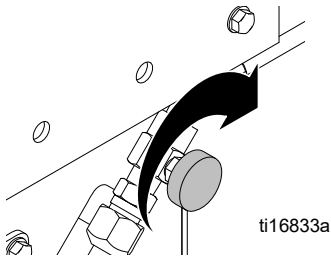

4. Close kettle manual shut-off valve.

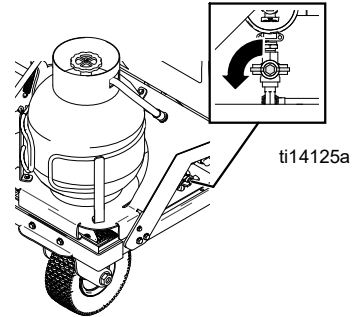

5. Fully close torch flame adjusting valve.

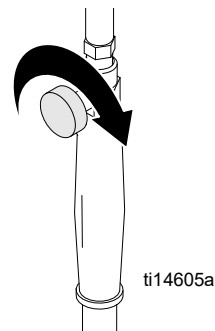

6. Turn main gas valve on propane tank OFF.

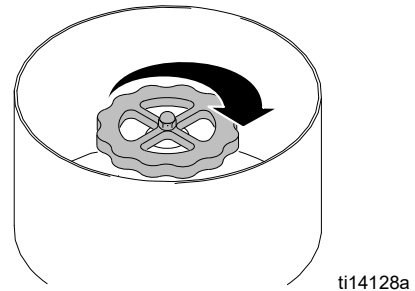

Always store LP-Gas cylinder outside and in an approved/secure storage locker.

This unit can be stored inside a building ONLY IF the LP-Gas cylinder has been removed.

Clean-Up for ThermoLazer 200/200TC/300TC

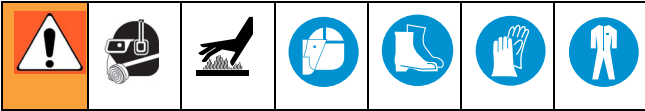

BURN HAZARD

Never scoop out remaining melted thermoplastic from kettle. Remaining thermoplastic can be left to harden inside the kettle and can be remelted at a later date.

1. Secure ThermoLazer by chocking wheels.

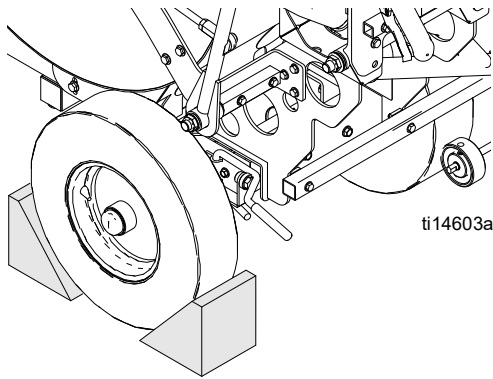

ti14603a

2. Use scraper to clean out trough and screed box.

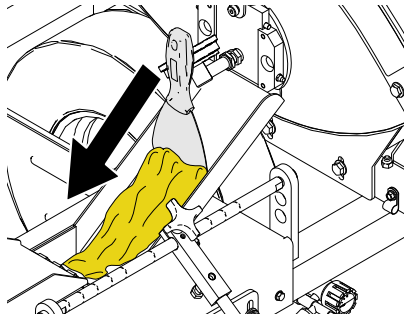

ti14529a

NOTICE

Be sure to thoroughly clean all material out of screed box and any open areas to prevent material from freezing moving parts of screed box. Always run all material out of each screed box before removing. Scrape out all remaining material before it sets within the screed box.

NOTICE

To prevent material from hardening and blocking flow, scrape all excess material off of external surfaces after each use, including the material trough.

NOTICE







Remove any remaining beads in the bead hopper and bead dispenser to prevent beads from clogging hopper and dispenser.

Transporting

Remove LP-Gas supply cylinder from ThermoLazer before transporting. Secure in an approved location and method as authorized by local, state, federal, national, and international agencies.

Always use the designated mounted lifting lugs when lifting the ThermoLazer. When lifting the ThermoLazer only use ANSI approved slings and equipment rated for a minimum of 2000 lb. Always use ANSI approved equipment for securing ThermoLazer to transporting equipment.

Clean-Up for ThermoLazer ProMelt

						
BURN HAZARD						
Never scoop out remaining melted thermoplastic from kettle without proper Personal Protective Equipment.						

- Secure unit by chocking all three wheels.
NOTE: Flow can be increased by propping up the left rear wheel and securing unit by chocking the other two wheels.

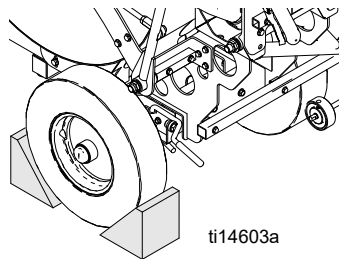

- Fully engage and lock brake.
- Rotate agitator handle to 9 o'clock and hold at this position by using the cover latch.

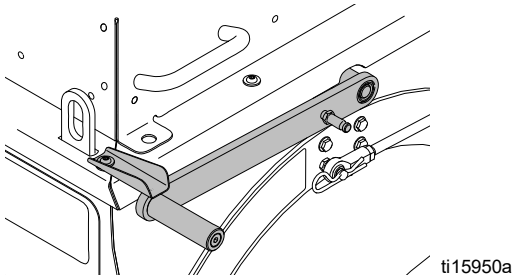

- Turn kettle burners ON to melt material.
- Open material gate and pour out remaining material in a heat-resistant container.
- Turn kettle burners OFF.
- Use long-handled scraper tool (VV) to remove material from inside of kettle. Start by scraping from the top of the kettle sides and work your way down so that as soon as the material collecting at the bottom begins to cool and harden you can scoop it out of the kettle. Collect material in a heat-resistant pan.

NOTE: If material becomes too hard to scrape or remove, reheat the kettle until the material becomes soft again.

- Repeat step 7.
- Rotate agitator handle to 3 o'clock and hold at this position by using the cover latch.
- Use small scraper to clean out trough, screed box, and agitators.

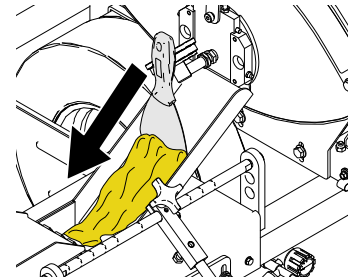

NOTICE

Be sure to thoroughly clean all material out of screed box and any open areas to prevent material from freezing moving parts of screed box. Always run all material out of each screed box before removing. Scrape out all remaining material before it sets within the screed box.

NOTICE

To prevent material from hardening and blocking flow, scrape all excess material off of external surfaces after each use.

NOTICE

Remove any remaining beads in the bead hopper and bead dispenser to prevent beads from clogging hopper and dispenser.

Transporting

Remove LP-Gas supply cylinder from the unit before transporting. Secure in an approved location and method as authorized by local, state, federal, national, and international agencies.

Always use the designated mounted lifting rings when lifting the unit. When lifting the unit, only use ANSI approved slings and equipment rated for a minimum of 2000 lb. Always use ANSI approved equipment for securing the unit to transporting equipment.

Maintenance

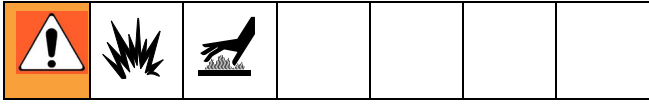

DAILY: Check gas lines and fittings for gas leaks. Use soap and water mixture or LP-gas leak detector to detect gas leaks.

DAILY: Check LP-gas supply hose for abrasions, cut or wear. Make sure hose fitting and tank fitting are free of debris before connecting.

DAILY: Make sure kettle gas safety valve (CC) rotates freely. Make sure valve freely moves in and out at the "PILOT" position.

DAILY: Make sure a good spark is being produced at the kettle pilot burner by the kettle pilot igniter electrode. Spark gap should be 0.17 - 0.20 in. (0.43 - 0.50 cm).

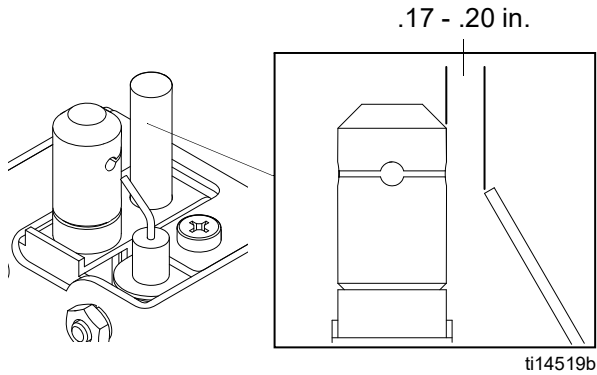

DAILY: Make sure kettle main burners (A) ignite when heat is required and shut-off when heat is not required.

DAILY: Make sure kettle pilot burner (C) is burning correctly. The flame should be 2 - 3 in. (5.0 - 7.6 cm) high and blue/orange in color.

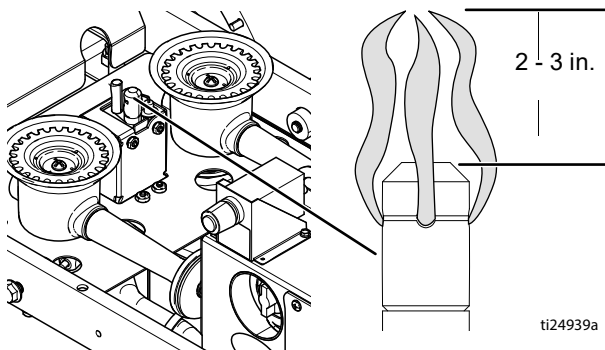

DAILY: Make sure LP-gas only flows to burner when safety shut-off valve knob is pressed in.

DAILY: Make sure the screed burners are burning correctly.

DAILY: Check bead box dispenser drive wheel (27) and tire (89) for foreign debris.

WEEKLY: Grease thermoplastic flow control gate valve guides.

WEEKLY: Check tire pressures.

WEEKLY: Check screed box bar carbide runners for wear.

WEEKLY: Clean the kettle to remove any debris or burnt material.

WEEKLY (or every 3000 lb of melting): Clean ProMelt Kettle of all overheated material.

MONTHLY: Grease agitator rod ball joint ends.

DAILY: Clean ProMelt kettle screen by scraping sides with long-handled scraper.

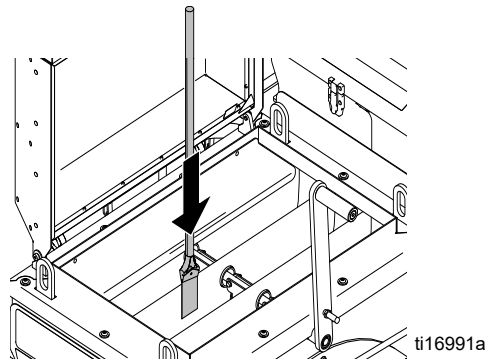

FatTrack Front Swivel Wheel System

(ThermoLazer 300TC/ProMelt)

ANNUALLY: Tighten nut on screw under dust cap until spring washer bottoms out. Then back off the nut 1/2 to 3/4 turns.

ANNUALLY: Tighten nut on screw until it begins to compress spring washer. Then tighten an additional 1/4 turn.

MONTHLY: Grease the wheel bearing.

PERIODICALLY: Check caster locking pin for wear. If pin is worn out, there will be play in the caster wheel. Reverse or replace the pin as needed.

PERIODICALLY: Check caster wheel alignment as necessary.

FatTrack Front Swivel Tire Alignment

Align front wheel as follows:

1. Loosen cap screw (86h).

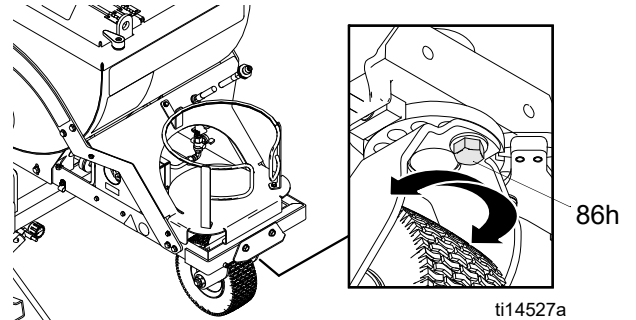

2. Rotate front wheel fork left or right, as necessary, to straighten alignment.
3. Tighten cap screw (86h). Push striper and let striper roll with hands off of striper.

NOTE: If striper rolls right or left, then repeat steps 1 and 3 until striper rolls straight.

Technical Data

		ThermoLazer 200/200TC	ThermoLazer 300TC		ThermoLazer ProMelt
		(24U280) (24U281)	with Rear Heat (24H622)	without Rear Heat (24H625)	(24H624)
	Fuel	Liquefied Petroleum Gas (LP-gas) (propane vapor)			
	Gas supply maximum pressure - psi (bar)	250 (17.24)			
Operating Pressure (psi - bar)	Kettle burners	3 (0.21)	0.5 (0.034)	0.5 (0.034)	3 (0.21)
	Torch	3 (0.21)	20 (1.38)	20 (1.38)	20 (1.38)
	Screed box front burners	3 (0.21)	20 (1.38)	20 (1.38)	20 (1.38)
	Screed box rear burners	3 (0.21)	20 (1.38)	N/A	20 (1.38)
Maximum Heating Capacity Btu/hr (kW)	Kettle burners (sum of burners)	(1) 30,000 (8.8)	(2) 30,000 (8.8)	(2) 30,000 (8.8)	(2) 100,000 (29.3)
	Torch	10,000 (2.93)	100,000 (29.3)	100,000 (29.3)	100,000 (29.3)
	Screed box front burner (sum of 3 burners)	27,000 (7.9)	27,000 (7.9)	27,000 (7.9)	27,000 (7.9)
	Screed box rear burner (sum of 4 burners)	36,000 (10.6)	36,000 (10.6)	N/A	36,000 (10.6)
	Total	103,000 (30.2)	193,000 (56.6)	157,000 (46.0)	263,000 (77.1)
Material Capacity lb (kg)	Gas	20 (9.1)	20 (9.1)		20,30 (9.1, 13.6)
	Main kettle	200 (91)	300 (136) - Thermoplastic traffic marking compound materials		
	Bead hopper	40 (18)	90 (40) - Type II glass bead		
	Maximum operating temperature - °F (°C)	450 (232)	450 (232)	450 (232)	480 (249)
	Front tire pressure - psi (bar)	N/A	45 (3.10)		
	Rear tire pressure - psi (bar)	N/A	60 (4.14)		
Physical	Weight - lb (kg)	260 (118)	300 (136)	295 (134)	350 (159)
	Length - in. (m)	44 (1.12)	72 (1.83)		
	Height - in. (m)	39 (1.00)	51 (1.3)		
	Width - in. (m)	33 (0.84)	48 (1.22)		
	Igniter battery	N/A	AA (1.5 V)		

Graco Standard Warranty

Graco warrants all equipment referenced in this document which is manufactured by Graco and bearing its name to be free from defects in material and workmanship on the date of sale to the original purchaser for use. With the exception of any special, extended, or limited warranty published by Graco, Graco will, for a period of twelve months from the date of sale, repair or replace any part of the equipment determined by Graco to be defective. This warranty applies only when the equipment is installed, operated and maintained in accordance with Graco's written recommendations.

This warranty does not cover, and Graco shall not be liable for general wear and tear, or any malfunction, damage or wear caused by faulty installation, misapplication, abrasion, corrosion, inadequate or improper maintenance, negligence, accident, tampering, or substitution of non-Graco component parts. Nor shall Graco be liable for malfunction, damage or wear caused by the incompatibility of Graco equipment with structures, accessories, equipment or materials not supplied by Graco, or the improper design, manufacture, installation, operation or maintenance of structures, accessories, equipment or materials not supplied by Graco.

This warranty is conditioned upon the prepaid return of the equipment claimed to be defective to an authorized Graco distributor for verification of the claimed defect. If the claimed defect is verified, Graco will repair or replace free of charge any defective parts. The equipment will be returned to the original purchaser transportation prepaid. If inspection of the equipment does not disclose any defect in material or workmanship, repairs will be made at a reasonable charge, which charges may include the costs of parts, labor, and transportation.

THIS WARRANTY IS EXCLUSIVE, AND IS IN LIEU OF ANY OTHER WARRANTIES, EXPRESS OR IMPLIED, INCLUDING BUT NOT LIMITED TO WARRANTY OF MERCHANTABILITY OR WARRANTY OF FITNESS FOR A PARTICULAR PURPOSE.

Graco's sole obligation and buyer's sole remedy for any breach of warranty shall be as set forth above. The buyer agrees that no other remedy (including, but not limited to, incidental or consequential damages for lost profits, lost sales, injury to person or property, or any other incidental or consequential loss) shall be available. Any action for breach of warranty must be brought within two (2) years of the date of sale.

GRACO MAKES NO WARRANTY, AND DISCLAIMS ALL IMPLIED WARRANTIES OF MERCHANTABILITY AND FITNESS FOR A PARTICULAR PURPOSE, IN CONNECTION WITH ACCESSORIES, EQUIPMENT, MATERIALS OR COMPONENTS SOLD BUT NOT MANUFACTURED BY GRACO. These items sold, but not manufactured by Graco (such as electric motors, switches, hose, etc.), are subject to the warranty, if any, of their manufacturer. Graco will provide purchaser with reasonable assistance in making any claim for breach of these warranties.

In no event will Graco be liable for indirect, incidental, special or consequential damages resulting from Graco supplying equipment hereunder, or the furnishing, performance, or use of any products or other goods sold hereto, whether due to a breach of contract, breach of warranty, the negligence of Graco, or otherwise.

Graco Information

For the latest information about Graco products, visit www.graco.com.

TO PLACE AN ORDER, contact your Graco distributor or call 1-800-690-2894 to identify the nearest distributor.

*All written and visual data contained in this document reflects the latest product information available at the time of publication.
Graco reserves the right to make changes at any time without notice.*

For patent information, see www.graco.com/patents.

Original instructions. This manual contains English. MM 3A1319

Graco Headquarters: Minneapolis
International Offices: Belgium, China, Japan, Korea

GRACO INC. AND SUBSIDIARIES • P.O. BOX 1441 • MINNEAPOLIS MN 55440-1441 • USA

Copyright 2011, Graco Inc. All Graco manufacturing locations are registered to ISO 9001.

www.graco.com
Revision L, March 2025