

332612D

EN

ToughTek M680a Mortar Sprayer

High performance, high output spray packages for high viscosity materials, such as mortars, mastics, and epoxies. For professional use only.



Important Safety Instructions

Read all warnings and instructions in all manuals. **Save all instructions.**

See page 6 for models and approvals information.

1000 psi (7 MPa, 69 bar) Maximum Fluid Working Pressure

150 psi (1.0 MPa, 10 bar) Maximum Air Inlet Pressure

100 psi (0.7 MPa, 7 bar) Maximum Pump Air Regulator Pressure

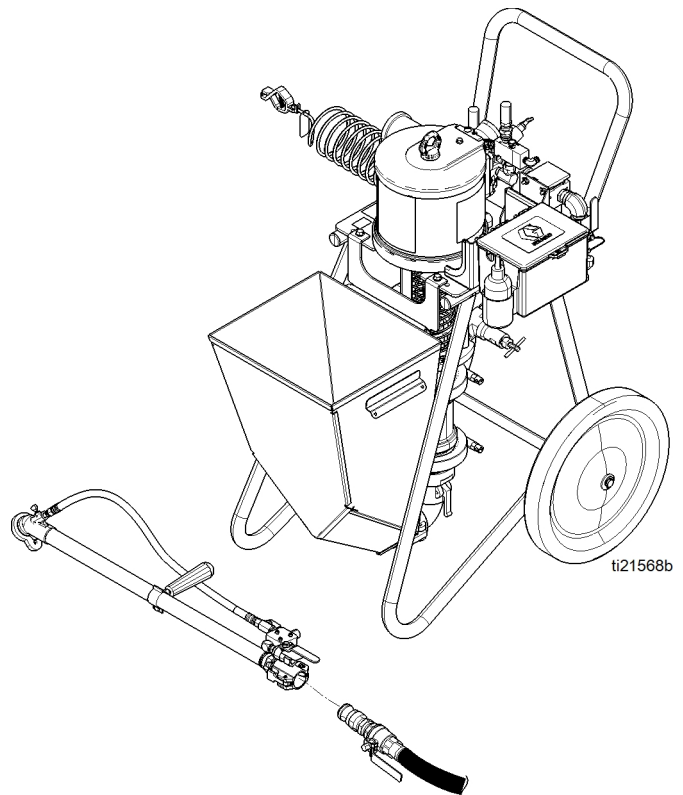

Contents

Related Manuals	2	Spray Techniques	25
Warnings	3	Installing Nozzle Retaining Cap	25
Models	6	Material Compatibility	25
Component Identification	8	Spray Adjustments (HTX 680 Applicator)	26
Overview	8	Flush	27
Details	9	Disassemble and Clean the Pump (Daily)	30
Mortar Spray Applicator	10	Shutdown	33
HTX 680 (Internal Air) Applicator	11	Maintenance	33
System Components	12	Preventative Maintenance	33
Grounding	13	Daily Maintenance	33
Setup	14	Corrosion Protection	33
Pressure Relief Procedure	15	Cart Maintenance	33
Wet Out the System	16	Troubleshooting	34
Mix the Material	19	Repair	36
Prime with Mortar or Epoxy	20	Replace Pump Components	36
Spray	22	Replace Air Motor	36
Prevent Packout	22	Replace Pump Lower	36
Before Starting or Stopping Material Flow	22	Parts	37
Spraying	22	Accessories	43
Spray Adjustments (Mortar Spray Applicator)	24	Technical Specifications	44
Air Flow Valve Adjustment	24	Graco Standard Warranty	47
Material Flow Adjustments	24		

Related Manuals











Manuals are available at www.graco.com.

Component manuals in English:







Manual	Description
332651	Mortar Spraying Tips
332767	Mortar Spray Applicators Operation - Parts
332768	HTX 680 Applicator Operation - Parts
312796	NXT Air Motors Instructions - Parts
332649	Pump Lower Instructions - Parts
332650	Pump Instructions - Parts

Warnings



The following warnings are for the setup, use grounding, maintenance, and repair of this equipment. The exclamation point symbol alerts you to a general warning and the hazard symbols refer to procedure-specific risks. When these symbols appear in the body of this manual or on warning labels, refer back to these Warnings. Product-specific hazard symbols and warnings not covered in this section may appear throughout the body of this manual where applicable.

 <h2 style="margin: 0;">WARNING</h2>	
   	<p>FIRE AND EXPLOSION HAZARD</p> <p>Flammable fumes, such as solvent and paint fumes, in work area can ignite or explode. To help prevent fire and explosion:</p> <ul style="list-style-type: none"> • Use equipment only in well ventilated area. • Eliminate all ignition sources; such as pilot lights, cigarettes, portable electric lamps, and plastic drop cloths (potential static arc). • Keep work area free of debris, including solvent, rags and gasoline. • Do not plug or unplug power cords, or turn power or light switches on or off when flammable fumes are present. • Ground all equipment in the work area. See Grounding instructions. • Use only grounded hoses. • Hold applicator firmly to side of grounded pail when triggering into pail. Do not use pail liners unless they are antistatic or conductive. • Stop operation immediately if static sparking occurs or you feel a shock. Do not use equipment until you identify and correct the problem. • Keep a working fire extinguisher in the work area.
    	<p>SKIN INJECTION HAZARD</p> <p>High-pressure fluid from dispensing device, hose leaks, or ruptured components will pierce skin. This may look like just a cut, but it is a serious injury that can result in amputation. Get immediate surgical treatment.</p> <ul style="list-style-type: none"> • Do not point dispensing device at anyone or at any part of the body. • Do not put your hand over the fluid outlet. • Do not stop or deflect leaks with your hand, body, glove, or rag. • Follow the Pressure Relief Procedure when you stop dispensing and before cleaning, checking, or servicing equipment. • Tighten all fluid connections before operating the equipment. • Check hoses and couplings daily. Replace worn or damaged parts immediately.

! WARNING

 	<p>EQUIPMENT MISUSE HAZARD</p> <p>Misuse can cause death or serious injury.</p> <ul style="list-style-type: none"> • Do not operate the unit when fatigued or under the influence of drugs or alcohol. • Do not exceed the maximum working pressure or temperature rating of the lowest rated system component. See Technical Specifications in all equipment manuals. • Use fluids and solvents that are compatible with equipment wetted parts. See Technical Specifications in all equipment manuals. Read fluid and solvent manufacturer's warnings. For complete information about your material, request SDSs from distributor or retailer. • Do not leave the work area while equipment is energized or under pressure. • Turn off all equipment and follow the Pressure Relief Procedure when equipment is not in use. • Check equipment daily. Repair or replace worn or damaged parts immediately with genuine manufacturer's replacement parts only. • Do not alter or modify equipment. Alterations or modifications may void agency approvals and create safety hazards. • Make sure all equipment is rated and approved for the environment in which you are using it. • Use equipment only for its intended purpose. Call your distributor for information. • Route hoses and cables away from traffic areas, sharp edges, moving parts, and hot surfaces. • Do not kink or over bend hoses or use hoses to pull equipment. • Keep children and animals away from work area. • Comply with all applicable safety regulations.
 	<p>MOVING PARTS HAZARD</p> <p>Moving parts can pinch, cut or amputate fingers and other body parts.</p> <ul style="list-style-type: none"> • Keep clear of moving parts. • Do not operate equipment with protective guards or covers removed. • Pressurized equipment can start without warning. Before checking, moving, or servicing equipment, follow the Pressure Relief Procedure and disconnect all power sources.
	<p>TOXIC FLUID OR FUMES HAZARD</p> <p>Toxic fluids and fumes can cause serious injury or death if splashed in the eyes or on skin, inhaled, or swallowed.</p> <ul style="list-style-type: none"> • Read SDSs to know the specific hazards of the fluids you are using. • Store the hazardous fluid in approved containers, and dispose of it according to applicable guidelines.
	<p>PERSONAL PROTECTIVE EQUIPMENT</p> <p>Wear appropriate protective equipment when in the work area to help prevent serious injury, including eye injury, hearing loss, inhalation of toxic fumes, and burns. This protective equipment includes but is not limited to:</p> <ul style="list-style-type: none"> • Protective eyewear, and hearing protection. • Respirators, protective clothing, and gloves as recommended by the fluid and solvent manufacturer.
	<p>SUCTION HAZARD</p> <p>Powerful suction could cause serious injury.</p> <ul style="list-style-type: none"> • Never place hands near the pump fluid inlet when pump is operating or pressurized.

Material Self-ignition

				
Some materials may become self-igniting if applied too thick. Read material manufacturer's warnings and material SDSs.				

Changing Materials

NOTICE
<p>Changing the material types used in your equipment requires special attention to avoid equipment damage and downtime.</p> <ul style="list-style-type: none"> • When changing materials, flush the equipment multiple times to ensure it is thoroughly clean. • Always clean the fluid inlet strainers after flushing. • Check with your material manufacturer for chemical compatibility. • When changing between epoxies and urethanes or polyureas, disassemble and clean all fluid components and change hoses.

Models

Includes ⁹ :	Model						
	262927	262909	262926	24T834	24T835	24T836	24T837
Pump installed on Cart 24T837 ¹	✓	✓	✓	✓	✓	✓	✓
Basic Spare Parts Kit ² (included in tool box)	✓	✓	✓	✓	✓	✓	✓
Feed Hopper 24T853 ³	✓	✓		✓		✓	
Standard 35 ft (1.7 m) Hose Bundle 24T852 ⁴	✓	✓	✓	✓	✓		
Flex Applicator 24T947 ⁵	✓			✓	✓		
HTX 680 Manifold Applicator 24U209 ⁶	✓	✓	✓				
Additional Spare Parts ⁷	✓						
Additional 25 ft (7.6 m) Hose Kit 24R254 ⁸	✓						

¹ Includes air motor, stainless steel pump lower, zero cavity relief valve, 1 in. male camlock outlet, air controls, and the two wheel cart.

² Includes gaskets for cam and groove fittings, complete pump repair soft seal kit, and pilot tube repair fittings.

³ Includes 10 gallon (38 liter) stainless steel hopper, hopper mounting, straight and 90° 2 in. female cam lock outlet.

⁴ Fluid hose portion of kit includes 1 in. x 25 ft fluid hose, 3/4 x 10 ft fluid whip hose, stainless steel shut off ball valve, and fluid cam lock ends. Air line portion of kit includes 38 ft air line with pump pilot line, air line quick disconnects, and mesh wrap. Includes 6 mil polyurethane bag tubes for fluid lines and air lines.

⁵ Flex applicator includes 23 in. (58 cm) flexible hose with cam lock fluid inlet, angled spray head, spray air volume control, spray air shut off valve, and motor pilot signal control valve, adjustable positions center air injection tube, rubber tip retainer, and includes three tip sizes. Flex applicator is for use in low pressure spraying of materials that pack out easily and that will be finished-troweled.

⁶ HTX 680 includes cam lock fluid inlet, angled aluminum spray head, spray air volume control, spray air shut off valve, and motor pilot signal control valve. HTX 680 uses venturi-type air injection fluid nozzles and aluminum screw on tip retainer. Includes four nozzle sizes, a Fine Finish adapter, and four Fine Finish tips. HTX 680 is for use in medium pressure spray of materials that do not pack out easily.

⁷ Additional spare parts option includes flex applicator and pole applicator parts (rubber retainer, 3/16, 4/16/ 8/16/ 9/16 in. tips, and air tube o-ring), HTX applicator parts (nozzle retainer and 4 mm, 6 mm, 8 mm, 10 mm nozzles and 1/8, 1/4, 3/8, 5/16 in. Fine Finish discs, air check valve, and spool o-rings), and pump rebuild kit.

⁸ Extends total length to 60 ft (18.3 m). Includes 25 ft x 1 in. fluid hose with cam lock fluid fittings, and 25 ft air hose assembly with hose quick disconnects and pilot tube.

⁹ See **Parts**, page 37, for details regarding what is included with each model.

Agency Approvals

Model	Certification
262927	 <p data-bbox="1047 457 1344 489">II 2 G Ex h IIA T5 Gb</p>
262909	
262926	
24T834	
24T835	
24T836	
24T837	

Component Identification

Overview

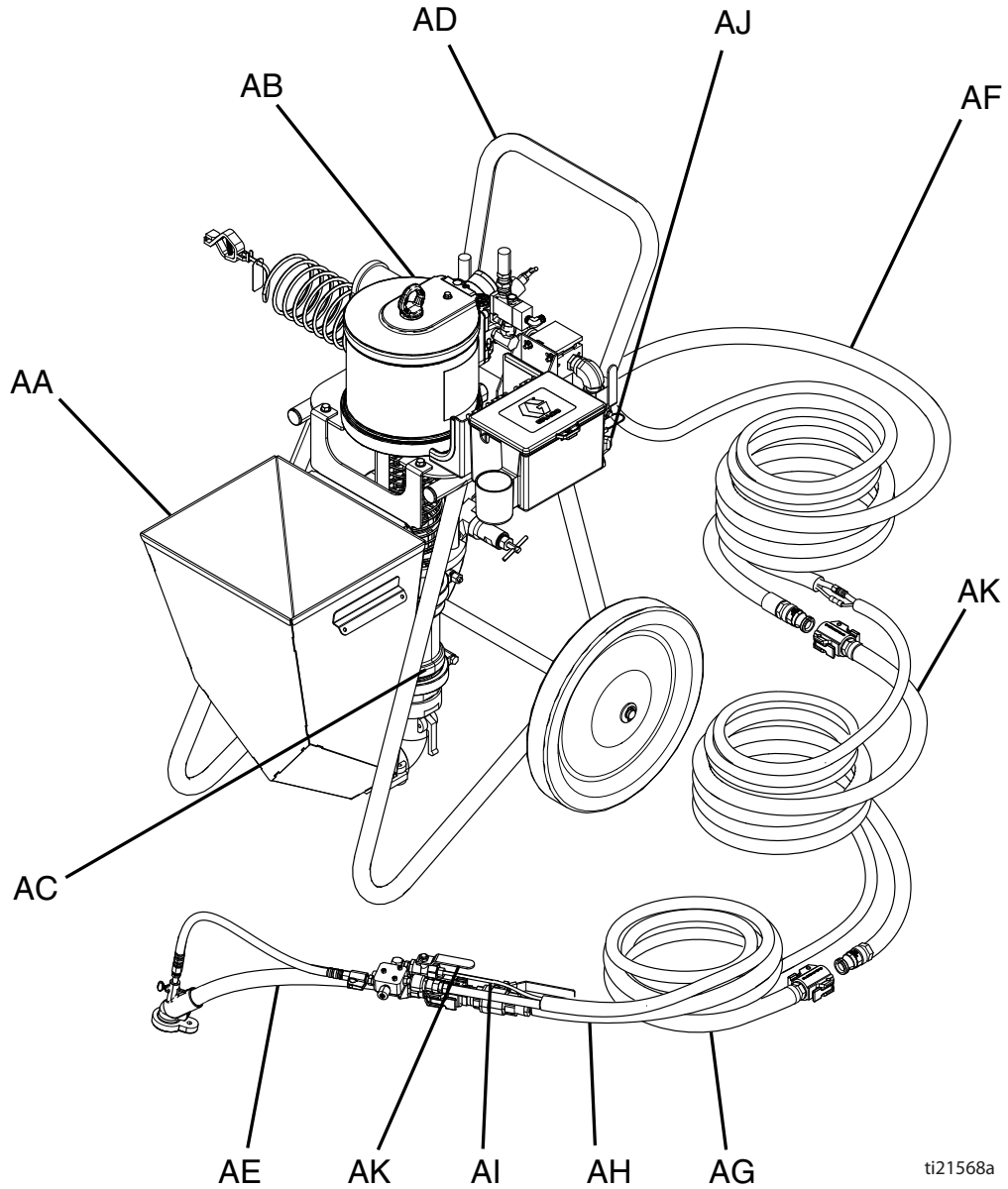

ti21568a

FIG. 1

Key:

AA Material Hopper

AB Air Motor

AC Lower

AD Cart

AE Applicator

AF Material Hose (connects pump to whip hose)

AG Material Whip Hose

AH Air Supply to Applicator (for Air Assist and Air Motor ON/OFF Pilot Valve), shown disconnected

AI Return Air to Air Motor ON/OFF Pilot Valve

AJ System Air Inlet

AK Optional hose extension

Details

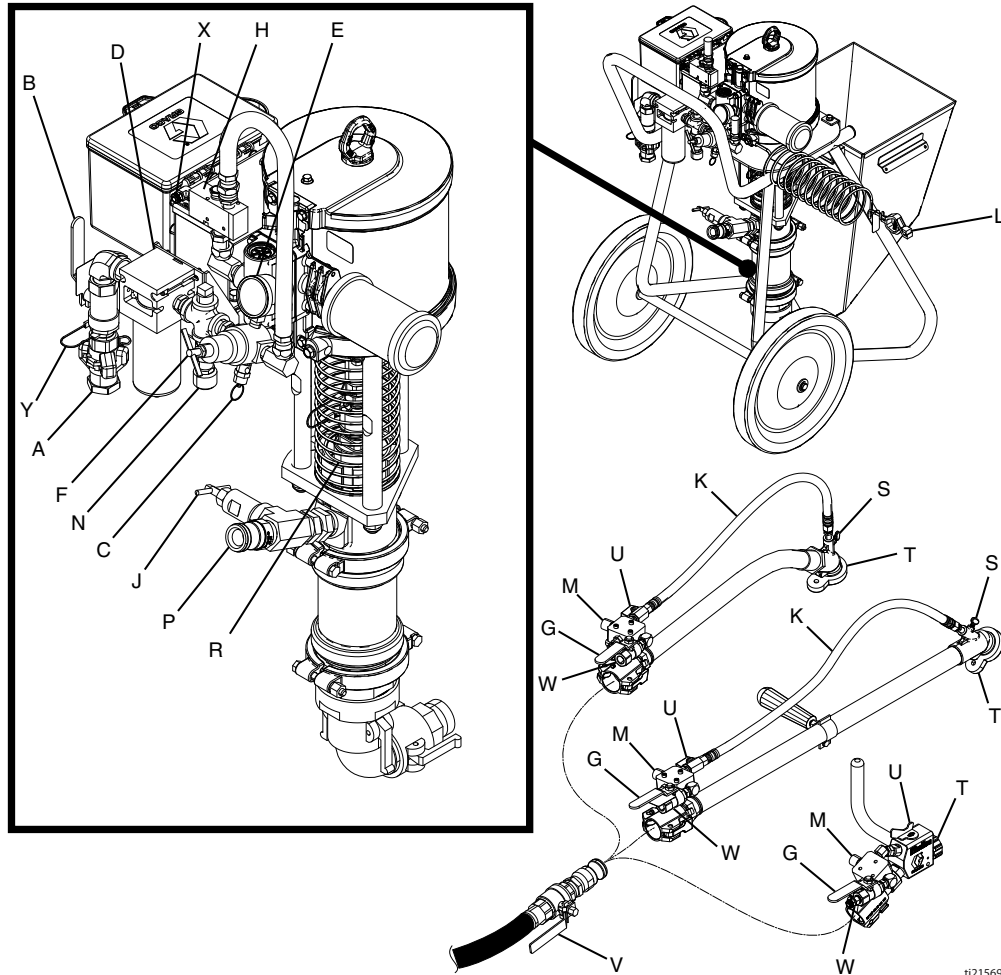

FIG. 2: Detailed View

Key:

- | | |
|--|---|
| <p>A Air Inlet, 3/4 npt(f) Claw (Chicago) Fittings</p> <p>B Bleed Type Master Air Valve (required)</p> <p>C Air Pressure Relief Valve</p> <p>D Air Filter (40 micron)</p> <p>E Motor Air Pressure Gauge</p> <p>F Motor Air Pressure Regulator Adjustment Knob</p> <p>G Pilot Ball Valve (starts/stops Air Motor)</p> <p>H Motor Air Pilot Valve</p> <p>J Zero Cavity Relief Valve</p> <p>K Air Assist Tube</p> <p>L Grounding Wire, required (see Grounding, page 13)</p> | <p>M Needle Valve for Air Assist Flow Control</p> <p>N Air Supply Quick Disconnect to Applicator Air Inlet Quick Disconnect (W)</p> <p>P Fluid Outlet, 1 in. Male Camlock Fitting</p> <p>R Packing Nut/Wet Cup under Spring Guard</p> <p>S Air Assist Nozzle Position Adjustment Screw</p> <p>T Applicator Tip Assembly</p> <p>U Air Assist Shutoff Ball Valve</p> <p>W Applicator Air Inlet Quick Disconnect</p> <p>X Pilot Valve Signal from Applicator Pilot Valve (G)</p> <p>Y Whip Check Hose Safety Cable</p> |
|--|---|

Mortar Spray Applicator

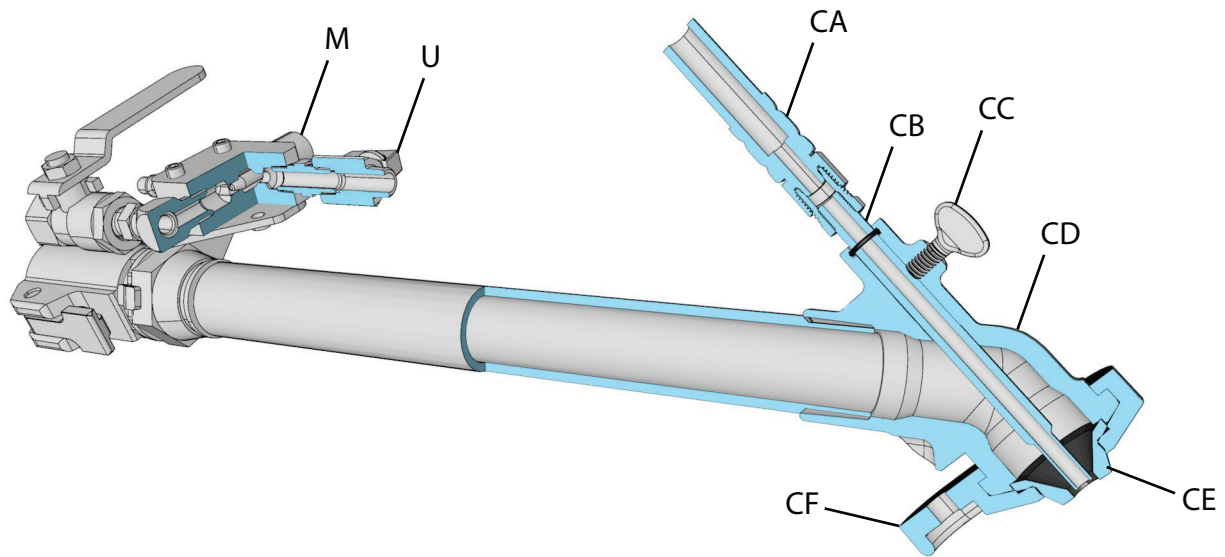

FIG. 3

Key:

- M Needle Valve for Air Assist Flow Control
- U Air Assist Shutoff Ball Valve
- CA Air Assist Air Line
- CB Air Needle (adjustable position)
- CC Air Needle Retaining Screw
- CD Fluid Housing
- CE Tip (Nozzle)
- CF Rubber Tip Retainer

HTX 680 (Internal Air) Applicator

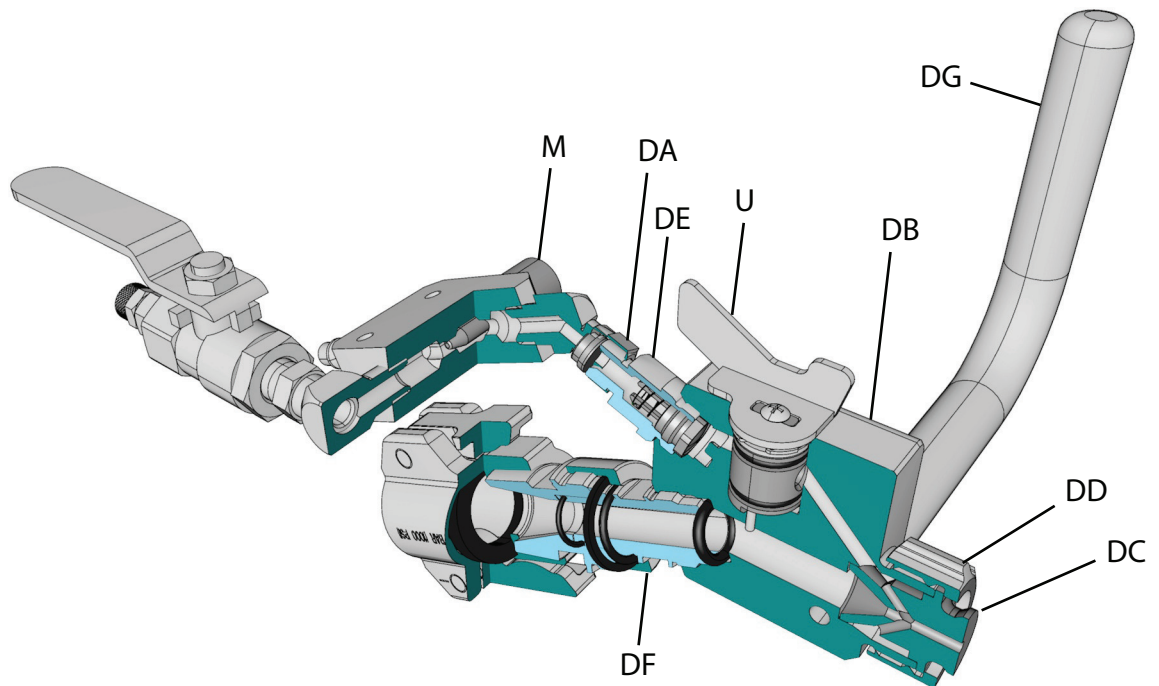



FIG. 4

Key:

- M Needle Valve for Air Assist Flow Control
- U Air Assist Shutoff Ball Valve
- DA Air Assist Air Line
- DB Fluid and Air Manifold
- DC Tip (Nozzle)
- DD Tip Retainer
- DE Air Check Valve
- DF Fluid Inlet Swivel
- DG Handle

System Components

* *Required system components.*

				
To avoid tipping over, ensure cart is on a flat and level surface. Failure to do so could result in injury or equipment damage.				

* **Bleed Type Master Air Valve (B)**

- Be sure the valve is easily accessible from the applicator.
- Required in your system to relieve air trapped between it and the air motor when the valve is closed.
 - Open to supply air to the motor.
 - Close to shut off air to the motor and bleed any trapped air from the motor.

* **Air Pressure Relief Valve (C)**

Automatically opens to relieve air pressure if set pressure exceeds preset limit.

Air Filter (D)

Removes harmful dirt and water from compressed air supply.





Air Regulator Adjustment (F)

Adjusts air pressure to the motor and fluid outlet pressure of pump. Read air pressure on gauge (E).



* **Zero Cavity Relief Valve (J)**

Open valve to relieve pressure if pump or hose packout occurs. Close valve when spraying.

NOTICE
To prevent material hardening in zero cavity relief valve, flush the valve after every time it is used. See Flush , page 27.

				
To avoid skin injection and splashing, never open a camlock hose or applicator fitting while there is pressure in the fluid line. See Pressure Relief Procedure , page 15.				

Grounding

				
<p>The equipment must be grounded to reduce the risk of static sparking and electric shock. Electric or static sparking can cause fumes to ignite or explode. Improper grounding can cause electric shock. Grounding provides an escape wire for the electric current.</p>				

Tools Required

- Grounding wires and clamps for pails
 - Two gallon (19 liter) metal pails
1. Connect the ground wire (L), Part No. 262908, to the ground stud on the air motor.

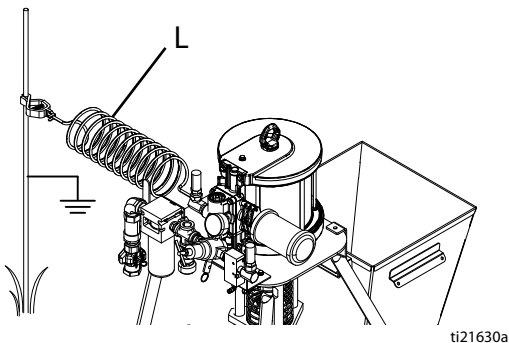

FIG. 5: Grounding Wire

2. Connect the other end of the ground wire to a true earth ground.
3. Ground the object being sprayed, fluid supply container, and all other equipment in the work area. Follow your local code. Use only electrically conductive air and fluid hoses.
4. Ground all solvent pails. Use only metal pails, which are conductive, placed on a grounded surface. Do not place pail on a non-conductive surface, such as paper or cardboard, which interrupts grounding continuity.

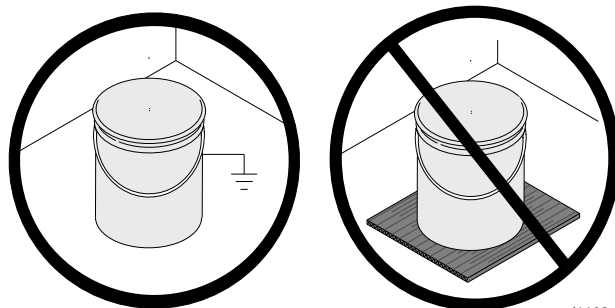

FIG. 6

Setup

Tools Required

- Two adjustable wrenches
 - Non-sparking hammer or plastic mallet
1. Ground sprayer. See **Grounding**, page 13.
 2. Check Throat Seal Liquid (TSL) level in packing nut (R). Fill 1/2 full with TSL.

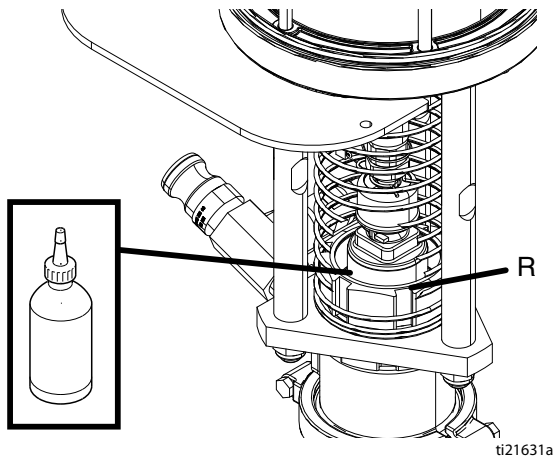

FIG. 7

3. Attach 1 in. x 25 ft electrically conductive fluid hose to pump outlet.

NOTE: The 3/4 in. hose will be connected to the end of the 1 in. hose at the factory.

4. Attach large air line from hose bundle to main air quick disconnect (N). See **Details**, page 9.
5. Attach small air tube from hose bundle to motor pilot signal (X). Use wrench to secure air tube in place. See **Details**, page 9.
6. Attach 3/4 in. hose to applicator fluid inlet.
7. Attach large air line from hose bundle to applicator quick disconnect (W). See **Details**, page 9.
8. Attach small air tube from hose bundle to air motor pilot ball valve (G) on applicator. Use wrench to secure air tube in place. See **Details**, page 9.

9. Wrap blue, velcro, camlock retaining straps around each camlock connection to secure.

NOTE: This includes the two camlocks between the hopper and pump lower, the camlock at the pump outlet, the camlocks on the fluid hoses, and the camlock on the applicator inlet. The retaining straps should be tight and must not be able to slide off camlock.

10. Going from applicator back to the system, wrap a zip tie around all hoses every few feet to secure them together.

11. Connect air supply hose:

- a. Close bleed type master air valve (B).
- b. Expand end of whip check cable (Y) and slide it over the end of your air hose.
- c. Connect air supply hose to 3/4 npt(f) claw fittings air inlet (A).
- d. Install safety clips in claw fittings.

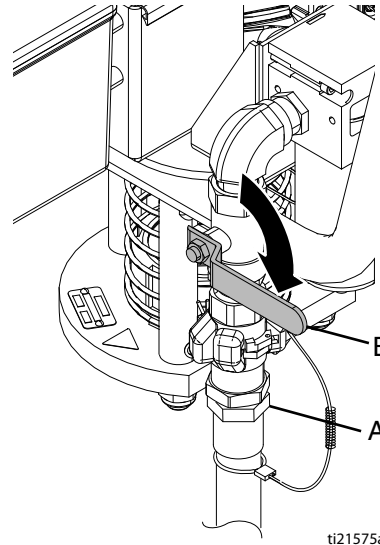

FIG. 8

12. Wet out the system with material flushing agent before using. See **Wet Out the System**, page 16.

Pressure Relief Procedure



Follow the Pressure Relief Procedure whenever you see this symbol.



This equipment stays pressurized until pressure is manually relieved. To help prevent serious injury from pressurized fluid, such as skin injection, splashing fluid and moving parts, follow the Pressure Relief Procedure when you stop spraying and before cleaning, checking, or servicing the equipment.

1. Flush the system. See **Flush**, page 27.
2. Close incoming air ball valve (B).

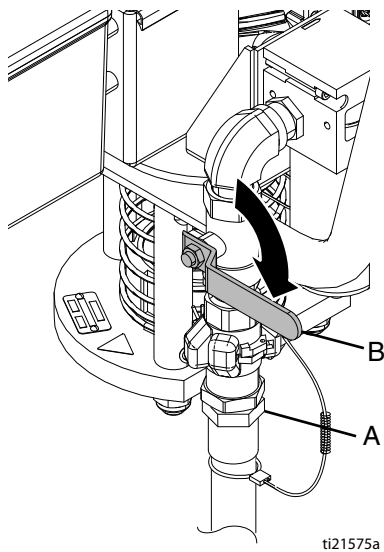

ti21575a

FIG. 9

3. Set air regulator (F) to zero pressure.

4. Hold applicator firmly against a grounded metal pail. Open the material ball valve (V) on the base of the applicator.

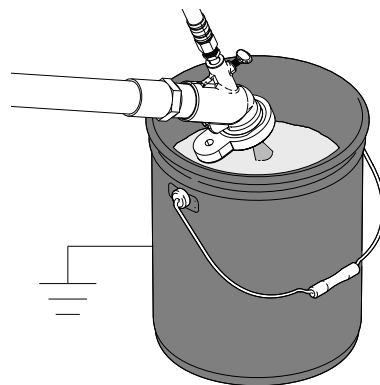

ti21632a

FIG. 10



5. If you suspect the applicator tip or hose is completely clogged, or that pressure has not been fully relieved after following the previous steps, slowly open the zero cavity relief valve (J) at the pump outlet. See **Details**, page 9.
6. If there is still pressure trapped down the line, very slowly loosen the threaded swivel fitting at the pump outlet while keeping it covered until the pressure is relieved.
7. Flush the zero cavity relief valve (J). See **Flush**, page 27.

NOTICE

To prevent material hardening in zero cavity relief valve, flush the valve after every use.

Wet Out the System



NOTICE

To prevent material curing in system, never load mortar or epoxy into dry system. Loading mortar or epoxy into a dry system will cause the material to stick to internal components and cure causing damage and requiring replacement of those parts.

Always wet out the system by circulating clean fluid through the applicator back into the hopper before loading any mixed mortar. This is normally done with the flushing fluid, but sometimes resin or commercially available concrete pump priming fluids are used depending on what material is being sprayed.

- Use the material flushing agent recommended on the material application data sheet.
- When finished, pump out the excess fluid. Then drain out remaining fluid by loosening the bottom cam fitting.

1. Close the bleed type master air valve (B).

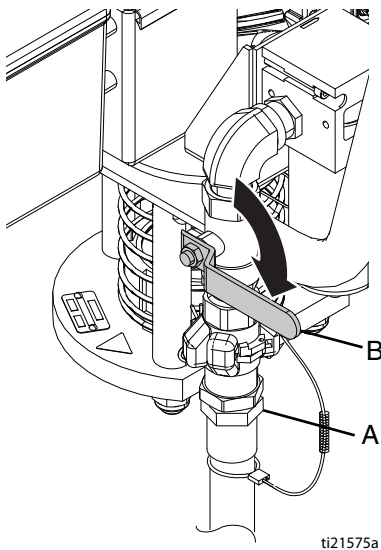

FIG. 11

2. Remove tip from applicator.

3. Partially fill the clean hopper with material flushing agent, depending on the material you will be spraying.
4. Turn air regulator adjustment knob (F) counterclockwise until it stops and gauge (E) reads zero.

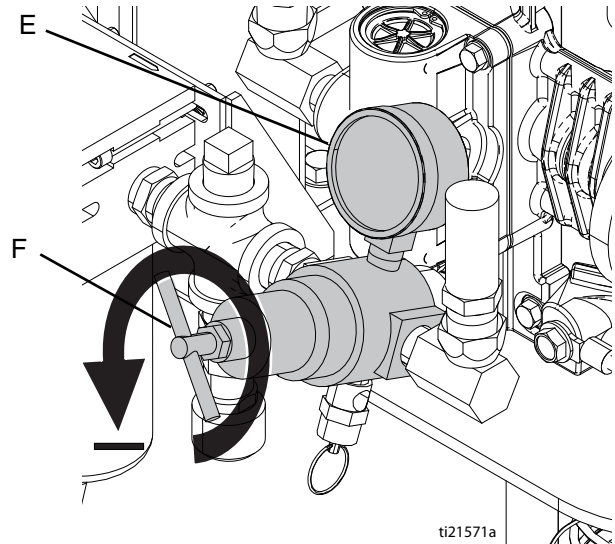

FIG. 12

5. Verify zero cavity relief valve (J) is closed.
6. Place applicator outlet in grounded pail.
7. Open the fluid ball valve (V) on the applicator.

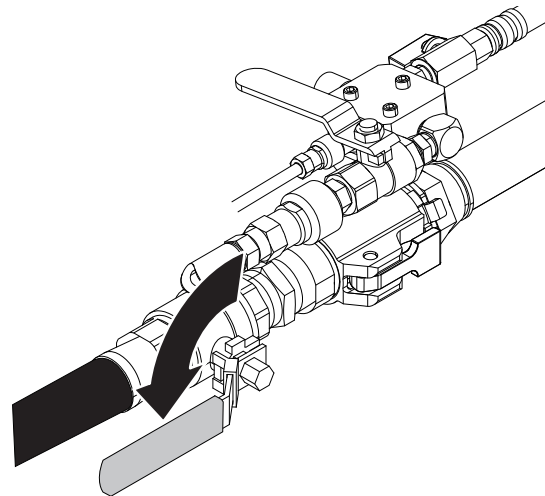
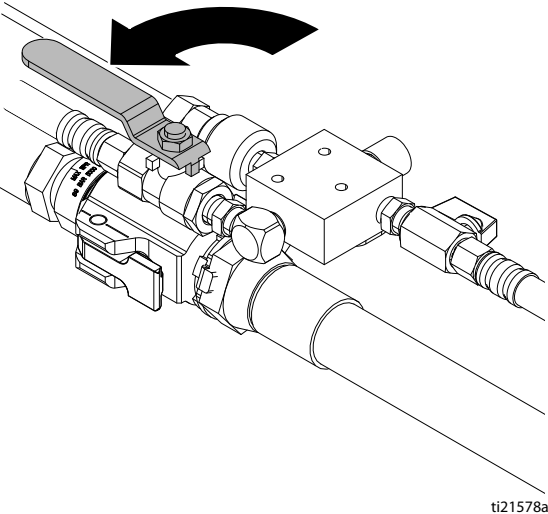

FIG. 13

8. Open the motor on/off pilot ball valve (G) located on base of applicator.



ti21578a

FIG. 14

9. Open bleed type master air valve (B).

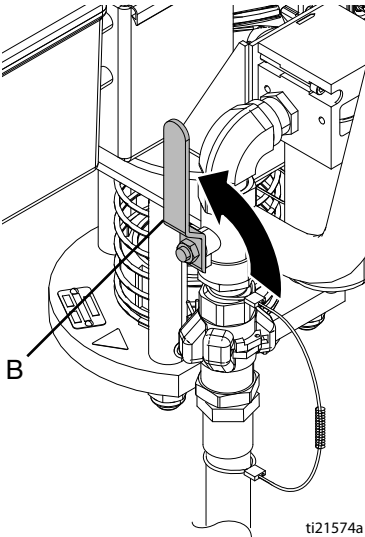

ti21574a

FIG. 15

10. Rotate the air regulator adjustment knob (F) clockwise until pump begins to move slowly.

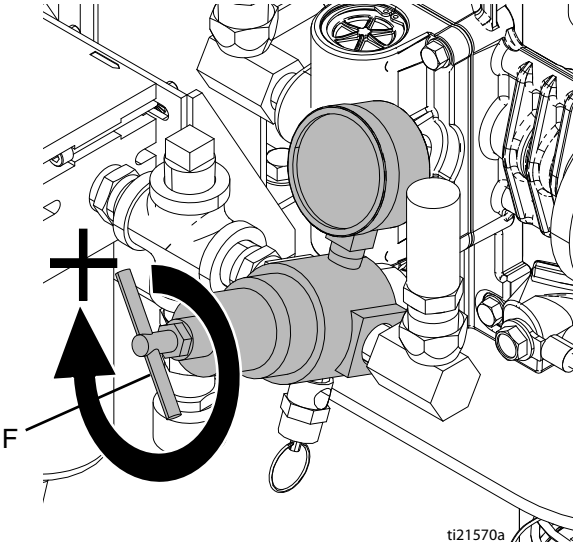

ti21570a

FIG. 16

NOTICE
To prevent damage to pump seals caused by cavitation, run the pump slowly until the system is primed.

11. Continue running the pump until all of the flushing fluid is dispensed into the pail. The system is now wetted out.

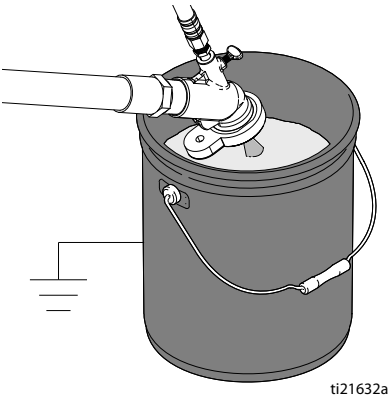

ti21632a

FIG. 17

Wet Out the System

12. To stop dispensing, close the air motor on/off pilot ball valve (G) and the main bleed type master air valve (B).

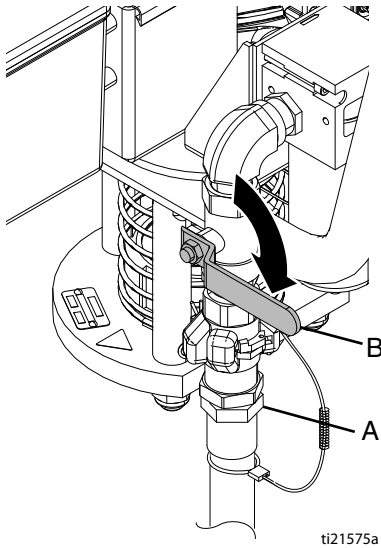

FIG. 18

13. If needed, drain remaining fluid from system.

NOTE: Materials that separate more easily may require draining the remaining fluid from the system. Check material data sheet to determine whether it is necessary to drain the remaining fluid from the system.

- a. Place grounded metal drain pan beneath pump lower inlet fittings.
- b. Remove hopper and fittings between hopper and pump lower.
- c. Use a screwdriver to lift the pump lower inlet ball. This will drain the remaining material from the pump lower. When the pump stops draining, release the pump lower inlet ball.
- d. Install fittings and hopper.
- e. Install camlock retaining straps.
- f. Starting at the pump, raise the hose bundle above your head and slowly move towards the applicator. As you move towards the applicator, the remaining fluid in the hose will drain from the applicator into the bucket.

Mix the Material

Always wet out the pump, hose, and applicator before loading the mortar or epoxy material. See **Wet Out the System**, page 16.

Always follow the material manufacturer's instructions for the material being sprayed. Mortar must be thoroughly mixed to a smooth consistency before loading it in the hopper.

- Always add the powder slowly to the fluid while mixing. Do not add fluid to the powder.
- In non-explosive environments only: Use a powerful mixer drive such as a minimum 800 watt, 1/2 in. drive, electric drill. Gear reduced drills work best. Drill should have high torque at 300-1200 rpm.
- A heavy-duty drywall mud "H" blade or large "Jiffy" blade generally works well for mixing.

NOTE: It will take most of the first batch of material to fill the pump and hoses.

Managing Mortar After Mixing:

- Pay close attention to the work life of the material being used.
- Only mix the mortar kits as needed. Do not let mixed mortar sit longer than necessary.
- Scrape mortar down the sides of the hopper as the hopper material level lowers. Do not let older mortar cure on the walls.
- Occasionally, do not refill the hopper until it is almost empty. This ensures all material in hopper is used while fresh.

Prime with Mortar or Epoxy



NOTICE

To prevent material curing in system, never load mortar into a dry system. Loading mortar into a dry system will cause the mortar to stick to internal components and cure causing damage and requiring replacement of those parts.

The applicator nozzle or tip must be removed during priming. Always push out any remaining “wet out” fluid into a waste container before circulating mortar. Always circulate clean mortar back into the hopper for a few minutes before beginning to spray.

1. Wet out the system. See **Wet Out the System**, page 16.
2. Mix the Material. See **Mix the Material**, page 19.
3. Close the bleed type master air valve (B).

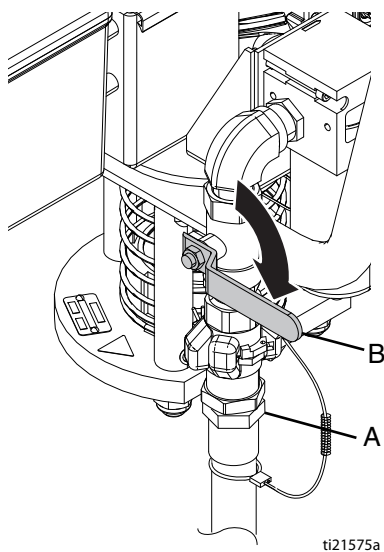

FIG. 19

4. Remove tip from applicator.

5. Fill the clean hopper with at least four gallons of the material to be sprayed. If using 60 ft of material hose, then fill with six gallons.
6. Turn air regulator adjustment knob (F) counterclockwise until it stops and gauge (E) reads zero.

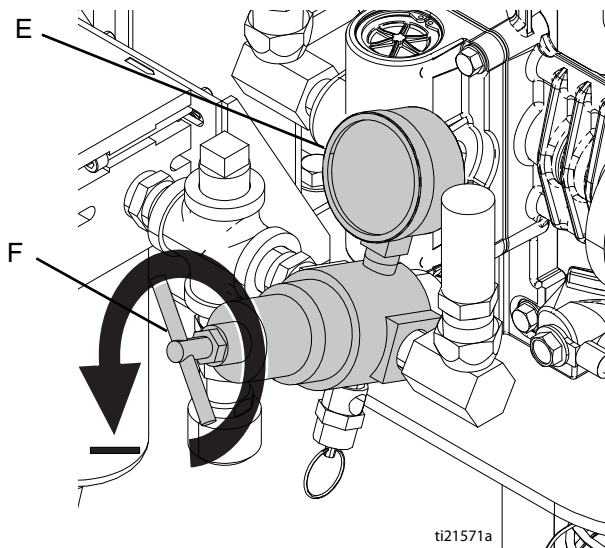

FIG. 20

7. Open the fluid ball valve (V) on the end of the fluid hose.
8. Place applicator outlet in a grounded metal five gallon waste container.
9. Open the motor ON/OFF pilot ball valve (G) located on base of applicator.

- Open bleed type master air valve (B).

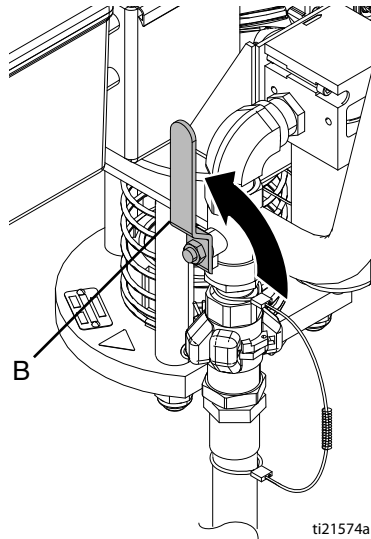

FIG. 21

NOTICE

To prevent damage to pump seals caused by cavitation, run pump slowly until the system is primed.

- Rotate the air regulator adjustment knob (F) clockwise until pump begins to move slowly.

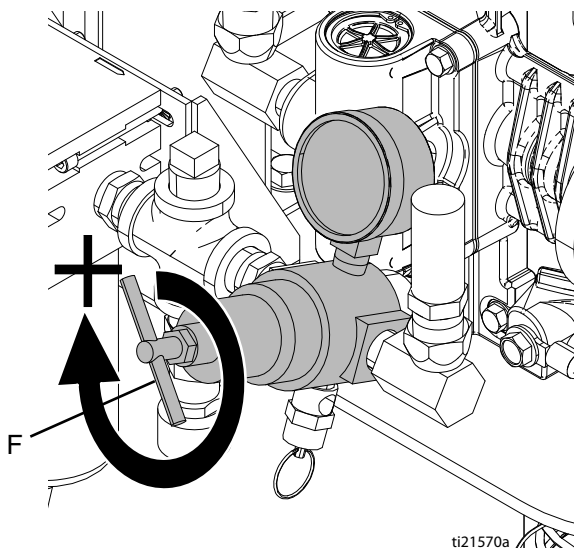

FIG. 22

- Continue running the pump until a steady stream of material comes from the applicator.

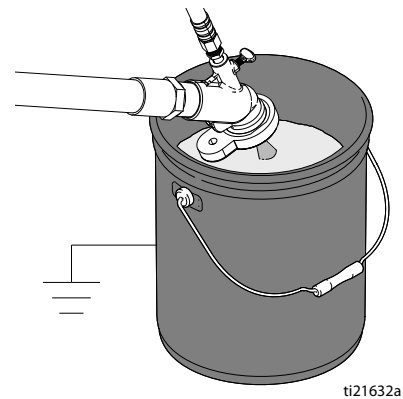

FIG. 23

- To stop dispensing, close the motor ON/OFF pilot ball valve (G). Do not close the fluid ball valve (V) when the air motor is running.

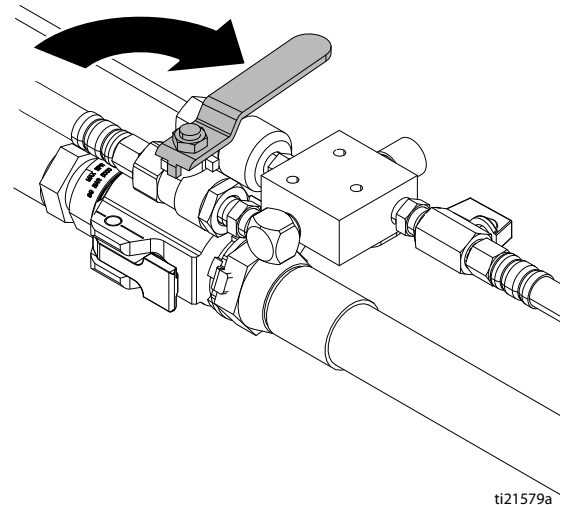

FIG. 24

- Place the applicator outlet into the hopper.
- With the fluid ball valve (V) open, open the motor ON/OFF pilot ball valve (G). Material will begin dispensing.
- Recirculate a few gallons of material to be sure the material is flowing properly.
- Install a tip onto applicator. The system is now primed and ready to spray.

Spray

NOTICE

Do not operate the pump motor with the applicator material ball valve (V) closed. This may cause the pump or hose to pack out.

Prevent Packout

To avoid “packing out” the pump or hose:

- Use the lowest pressure and largest nozzle size that provides an acceptable spray pattern. This will also result in seals and wear parts lasting much longer.
- Do not use any more fluid hose than is necessary.
- Use an applicator with a rubber tip retainer that will blow off if it plugs.

Before Starting or Stopping Material Flow

- Never dead end the pump against the fluid shut-off ball valve.
- Start and stop the fluid flow with the red-handled brass air motor pilot valve at the applicator.
- Always have the atomizing air turned on before and after spraying fluid.

Before Starting Material Flow

1. Always open the air assist valve (U) and adjust air assist needle valve (M) first.
2. Open applicator material ball valve (V) second.
3. Open (turn on) the motor pilot ball valve (G) last.

Before Stopping Material Flow

1. Always close (turn off) the motor pilot ball valve (G) first.
2. Close applicator material ball valve (V) second.
3. Turn off the air assist valve (U) last.

Spraying



NOTICE

Do not allow pump to run without material in the hopper. It will quickly accelerate to a high speed causing pump seal damage.

NOTICE

To prevent material curing in system, never load mortar into a dry system. Loading mortar into a dry system will cause the mortar to stick to internal components and cure causing damage and requiring replacement of those parts.

1. **Wet Out the System**, page 16.
2. **Mix the Material**, page 19.
3. **Prime with Mortar or Epoxy**, page 20.

NOTICE

Failure to flush prior to material curing in the system will result in damage to system and may require replacement of all system parts in contact with the material.

4. Turn air regulator adjustment knob (F) counterclockwise until it stops and gauge (E) reads zero.

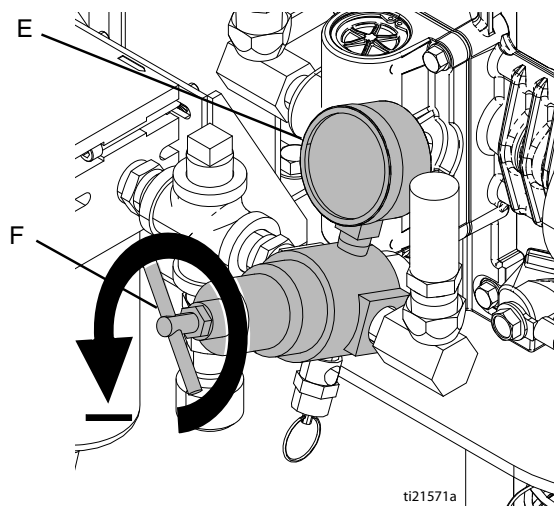
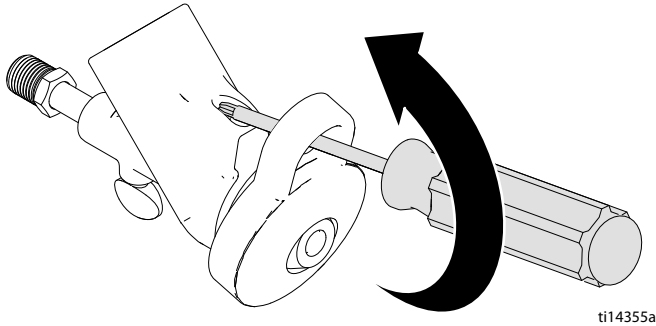

FIG. 25

5. Install tip on applicator by stretching rubber retainer with a screwdriver or screwing on retainer, depending on your application kit.



ti14355a

FIG. 26

6. Open air assist valve (U) and adjust the air assist needle valve (M). See **Details**, page 9.
7. Open the material ball valve (V) on the base of the applicator.

NOTICE

Do not operate the pump motor with the applicator material ball valve (V) closed. This may cause the pump or hose to pack out.

8. Open the pilot ball valve for air motor (G) located on base of applicator. See **Details**, page 9. Material will begin dispensing.

9. Adjust air motor regulator adjustment knob (F) until desired material flow rate is achieved. Turn clockwise to increase pressure, counterclockwise to decrease pressure.

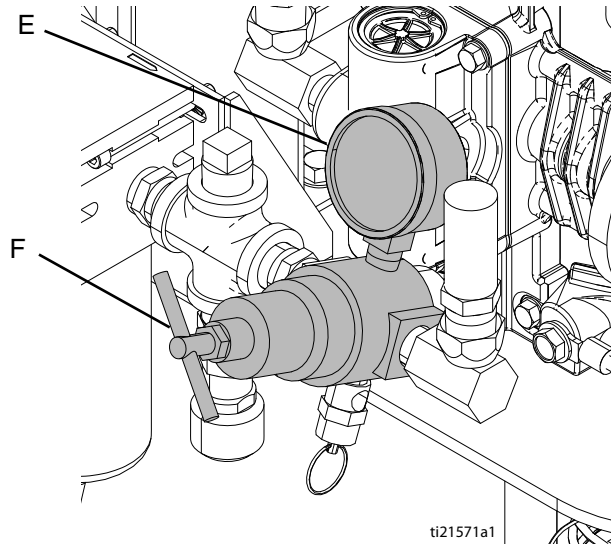

ti21571a1

FIG. 27

NOTE: See **Spray Adjustments (Mortar Spray Applicator)**, page 24 or **Spray Adjustments (HTX 680 Applicator)**, page 26 for details about all of the adjustments that can be made to the way the system sprays.

10. If the system is approaching its cure time or the system will be idle for enough time for material to begin curing in the system, Flush the system. See **Flush**, page 27.

NOTICE

Failure to flush prior to material beginning to cure in the system will result in damage to system and may require replacement of all parts in contact with the material.

11. If the flushed system will be idle for more than 90 minutes, Disassemble and Clean the Pump (Daily). See **Disassemble and Clean the Pump (Daily)**, page 30.

Spray Adjustments (Mortar Spray Applicator)

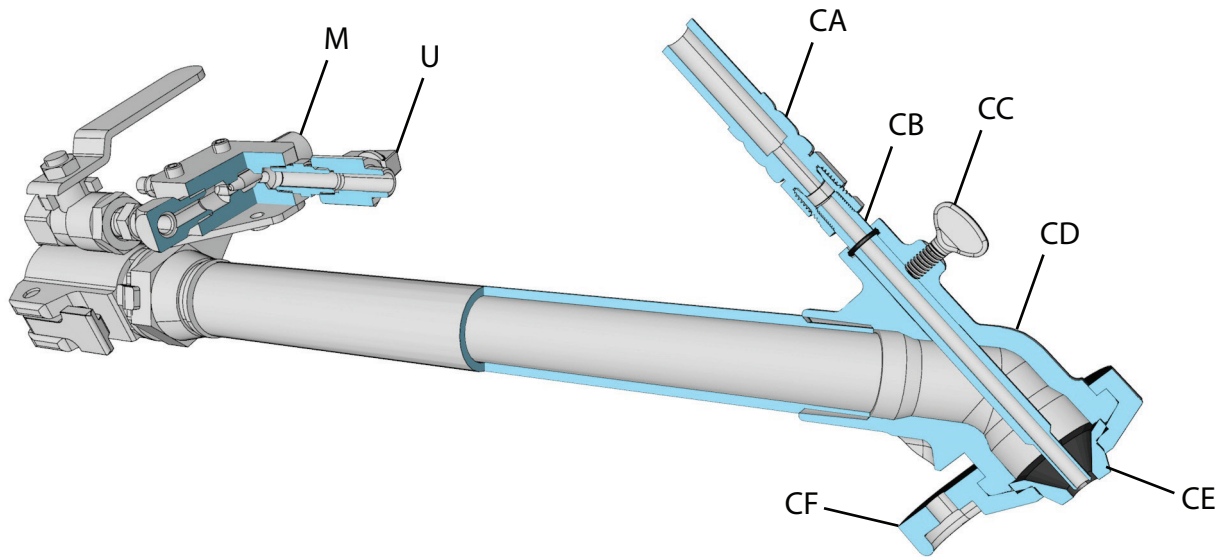

FIG. 28

Key:

- M Needle Valve for Air Assist Flow Control
- U Air Assist Shutoff Ball Valve
- CA Air Assist Air Line
- CB Air Needle (adjustable position)
- CC Air Needle Retaining Screw
- CD Fluid Housing
- CE Tip (Nozzle)
- CF Rubber Tip Retainer

General Adjustments

The spray pattern can be adjusted by changing:

- Tip (CE) size
- Fluid flow, use air motor regulator adjustment knob (G)
- Air flow, use needle valve (M)
- Air needle (CB) position

Adjust Air Flow: Fully open the air assist valve (U), while adjusting the needle valve (M) for the minimum air flow necessary for a good pattern. Air bleeds from the applicator nozzle whenever the applicator air assist valve (U) is open. Close the valve to stop the air flow, if desired. Otherwise, the air valve can stay open during priming. Air must be on prior to fluid flow.

Adjust Air Needle (CB) position: Ensure the air needle (CB) is slightly behind the tip (CE).

NOTE: Installing needle too far forward can restrict or completely block material flow. This can result in the retainer (CF) blowing off. Installing the needle too far back can raise the pressure behind the fluid enough to blow the retainer (CF) off and can cause dripping.

Air Flow Valve Adjustment

To decrease air flow, turn valve knob clockwise.

To increase air flow, turn valve knob counterclockwise.

Check material and thin as needed to maintain the proper consistency. The material may thicken as it sits and could slow down application or affect the spray pattern.

Flush and dry applicator thoroughly at the end of each use. Tips and retainers must be cleaned by hand.

Material Flow Adjustments

For a lighter spray pattern, adjust the air needle closer to the fluid nozzle and/or reduce the fluid flow.

For a heavier spray pattern, adjust the air needle farther back from the fluid tip and/or increase the fluid flow.

NOTE: Withdrawing needle too far can force air pressure back into fluid hose, slowing material flow.

Spray Techniques

1. Test the spray pattern on cardboard. Hold the applicator 6-18 in. (150-450 mm) from the surface. Use this spraying distance for most applications.
2. Adjust fluid flow until material flow is adequate.
3. Adjust the applicator air assist needle valve to achieve a uniform round spray pattern.
4. Consider the size of aggregate in the material and the coarseness of the spray pattern. Larger nozzles allow heavier patterns.
5. Overlap each stroke 50%. A circular overlapping pattern may give the best results, and is obtained by grasping the flex-head and swinging the head around as the hose flexes.

When spraying small confined areas use the valve and knob to make fine adjustments without adjusting the pump.

Typically desired spray pressure is 20-25 psi (140-170 kPa, 1.4-1.7 bar) on the motor air regulator (F). Higher pressures may cause excessive wear on the fluid pump. Select a fluid tip large enough to spray at low pressure. Some materials will packout at higher pressure.

Installing Nozzle Retaining Cap

1. Place nozzle retaining cap over top lip of applicator housing.
2. Insert screwdriver through hole in tab of nozzle retaining cap.

3. Push screwdriver head against notch on applicator tip and pry nozzle retaining cap over lip until it snaps into place.

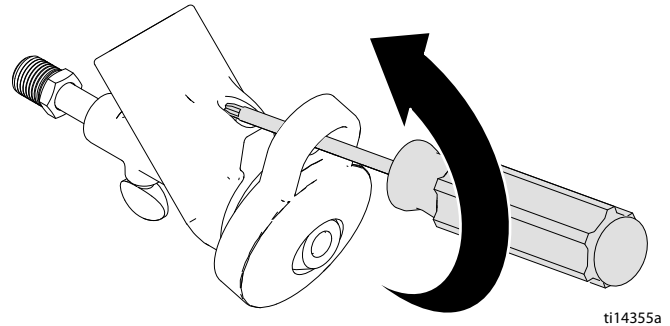

FIG. 29

4. Turn the rubber retainer back and forth to be sure it is fully seated.

Material Compatibility

NOTICE

To prevent the seals and rubber tip from swelling, do not leave solvent in the applicator when not in use.

The nylon hose in the Flex Applicator is compatible with solvents. The rubber gasket in the cam and groove inlet fitting and the rubber nozzle retainer should be hand cleaned and dried after each use.

Spray Adjustments (HTX 680 Applicator)

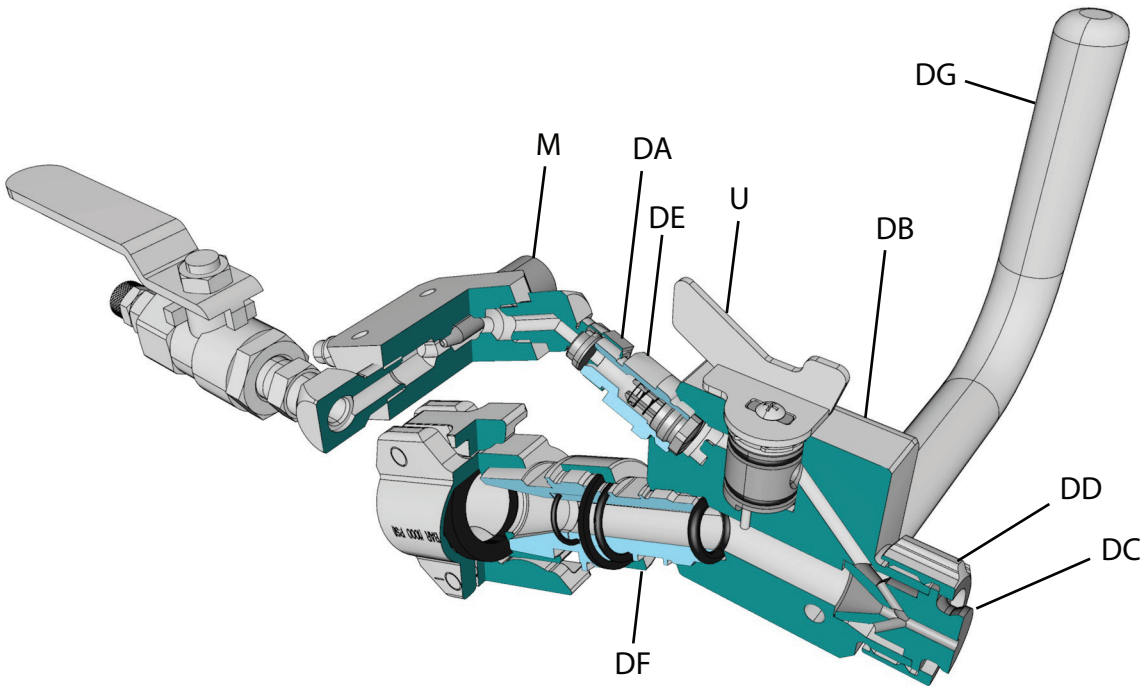

FIG. 30

Key:

- M Needle Valve for Air Assist Flow Control
- U Air Assist Shutoff Ball Valve
- DA Air Assist Air Line
- DB Fluid and Air Manifold
- DC Tip (Nozzle)
- DD Tip Retainer
- DE Air Check Valve
- DF Fluid Inlet Swivel
- DG Handle

The spray pattern can be adjusted by changing:

- Tip (DC) size
- Fluid flow, use air motor regulator adjustment knob (G)
- Air flow, use needle valve (M)

The standard applicator adjustment is to fully open the air assist valve (U), while adjusting the needle valve (M) for the minimum air flow necessary for a good pattern.

Air bleeds from the applicator nozzle whenever the applicator air assist needle valve (M) is open. Close the valve (U) to stop the majority of air flow, if desired. Some air will still bleed through valve (U) to help keep the air passages clean. Otherwise, the air valve (U) can stay open during priming. Air must be on prior to any fluid flow.

Adjusting the spray pattern requires testing to balance the fluid flow and the air to the applicator, and requires the correct tip size.

Always run full air volume through the applicator when you are done spraying to remove any fluid residue. Remove and clean the tip (DC) by hand. Remove the air check valve (DE) to be sure no fluid has backed up to the check valve. If it has, remove and clean air spool valve (U).

Fine Finish pattern discs and adapter kit 287227 is included and can be added for more pattern control. See manual 310617.

Flush



NOTICE

Failure to flush prior to material curing in the system will result in damage to system and may require replacement of all system parts in contact with the material.

NOTICE

If the zero cavity pressure relief valve has been used to relieve pressure, the valve must be flushed to prevent material hardening in zero cavity relief valve. If that is not sufficient, remove, disassemble, and clean the valve then reinstall.

- Flush if the materials in the system are about to reach their cure time.
- Flush any time the flow rate starts to decrease as this is a sign that material is starting to thicken and cure.
- Always flush the system at least twice, draining all material flushing agent between flushes then replacing with clean material flushing agent.
- For some mortars, it is recommended to flush every 3-5 kits. Others can run continuously without flushing. See material manufacturer recommendation.

1. Close the bleed type master air valve (B).

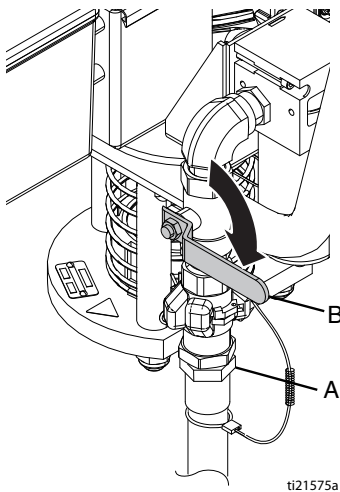

FIG. 31

2. Remove applicator tip and retainer.

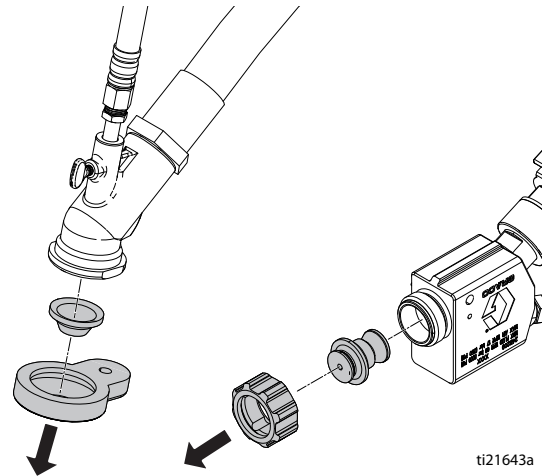

FIG. 32

3. Place applicator outlet in a waste container. The waste container must be large enough to hold all dispensed material.

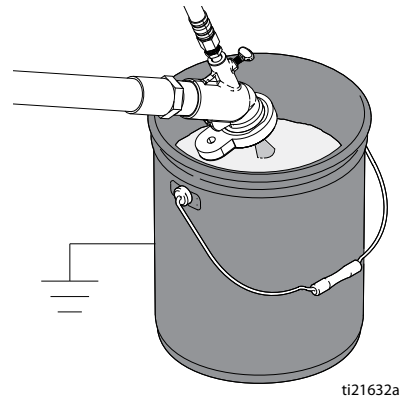

FIG. 33

4. With air assist air flowing, open the material ball valve (V) on the base of the applicator.
5. Open the pilot ball valve (G) located on base of applicator.

6. Open bleed type master air valve (B) to begin dispensing.

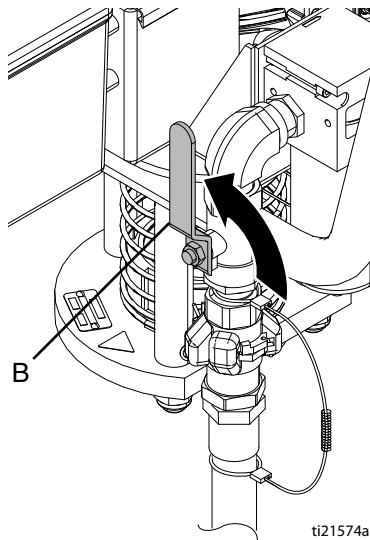

FIG. 34

7. When the material level in the hopper is within a few inches of the material inlet at the bottom:
 - a. Scrape the material down the sides of the hopper.
 - b. Fill the hopper with water or solvent as the material runs out and continue dispensing.
8. Keep the hopper filled with material flushing agent while dispensing.

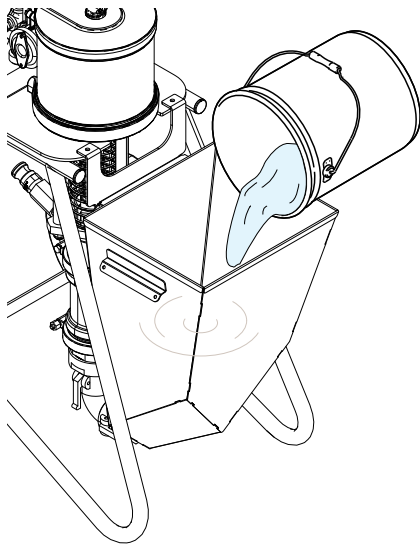

FIG. 35

NOTE: be prepared to decrease the air pressure when the material exiting the hose changes to water or solvent. Water and solvent pump more easily so pump speed will increase.

9. When water or solvent begins to exit the applicator outlet, close the pilot ball valve (G) located on base of applicator to stop dispensing.
10. Place applicator in the system hopper with the outlet pointing down to enable fluid circulation.

NOTE: If flushing with solvent, do not submerge the applicator in the solvent.

11. Circulate clean water or solvent:
 - a. Fill the system hopper with clean water or solvent.

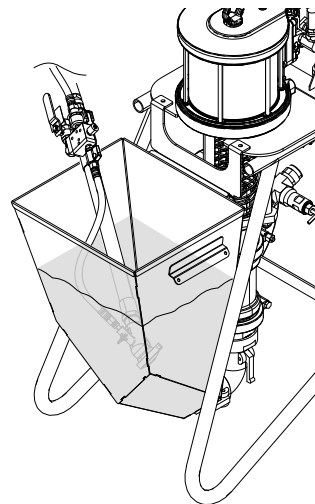

FIG. 36

- b. Use a scrub brush to scrub the walls of the hopper.
- c. Open the pilot ball valve (G) on applicator to begin circulating water or solvent.
- d. Run the pump at 60-90 cycles per minute for 3-5 minutes. Adjust air pressure as necessary to maintain 60-90 cycles per minute.

NOTE: High flushing fluid velocity is the most important item for effective cleaning. The fluid hose should shake while the pump is running. This is necessary to maximize the cleaning effects of flushing.

- e. While pumping at 60-90 cycles per minute, close then open the pilot ball valve (G) many times to clean it. Each time the pilot ball valve (G) is closed, close then open the fluid ball valve (V) to flush the fluid ball valve. Ensure fluid ball valve is open before opening pilot ball valve (G).
- f. Starting at the pump, raise the hose bundle above your head and slowly move towards the applicator. As you move towards the applicator, the remaining fluid in the hose will drain from the applicator into the bucket.

NOTE: When the fluid ball valve gets hard to operate, it should be disassembled, cleaned, and re-packed with grease.

- f. Decrease air pressure to air motor back to operating pressure.
 - g. Close the air motor pilot ball valve (G).
 - h. Place applicator outlet in a grounded metal waste container.
 - i. Open air motor pilot ball valve (G) to dispense into grounded metal waste container.
 - j. Dispense into grounded metal waste container until hopper is almost empty then close air motor pilot ball valve (G).
 - k. Repeat this entire “Circulate clean water or solvent” step one more time to ensure system is thoroughly flushed.
12. After performing the previous step at least twice, drain remaining flushing fluid from system:
- a. Place grounded metal drain pan beneath pump lower inlet fittings.
 - b. Remove hopper and fittings between hopper and pump lower.
 - c. Use a screwdriver to lift the pump lower inlet ball. This will drain the remaining material from the pump lower. When the pump stops draining, release the pump lower inlet ball.
 - d. Install fittings and hopper.
 - e. Install camlock retaining straps.
13. Disassemble and clean the pump at the end of every day. The procedure takes about 10 minutes. See **Disassemble and Clean the Pump (Daily)**, page 30.

Disassemble and Clean the Pump (Daily)

Suggested Tools

- 5/8 in. box end wrench or 5/8 in. socket and ratchet
- Rubber mallet (to break items loose, if necessary)

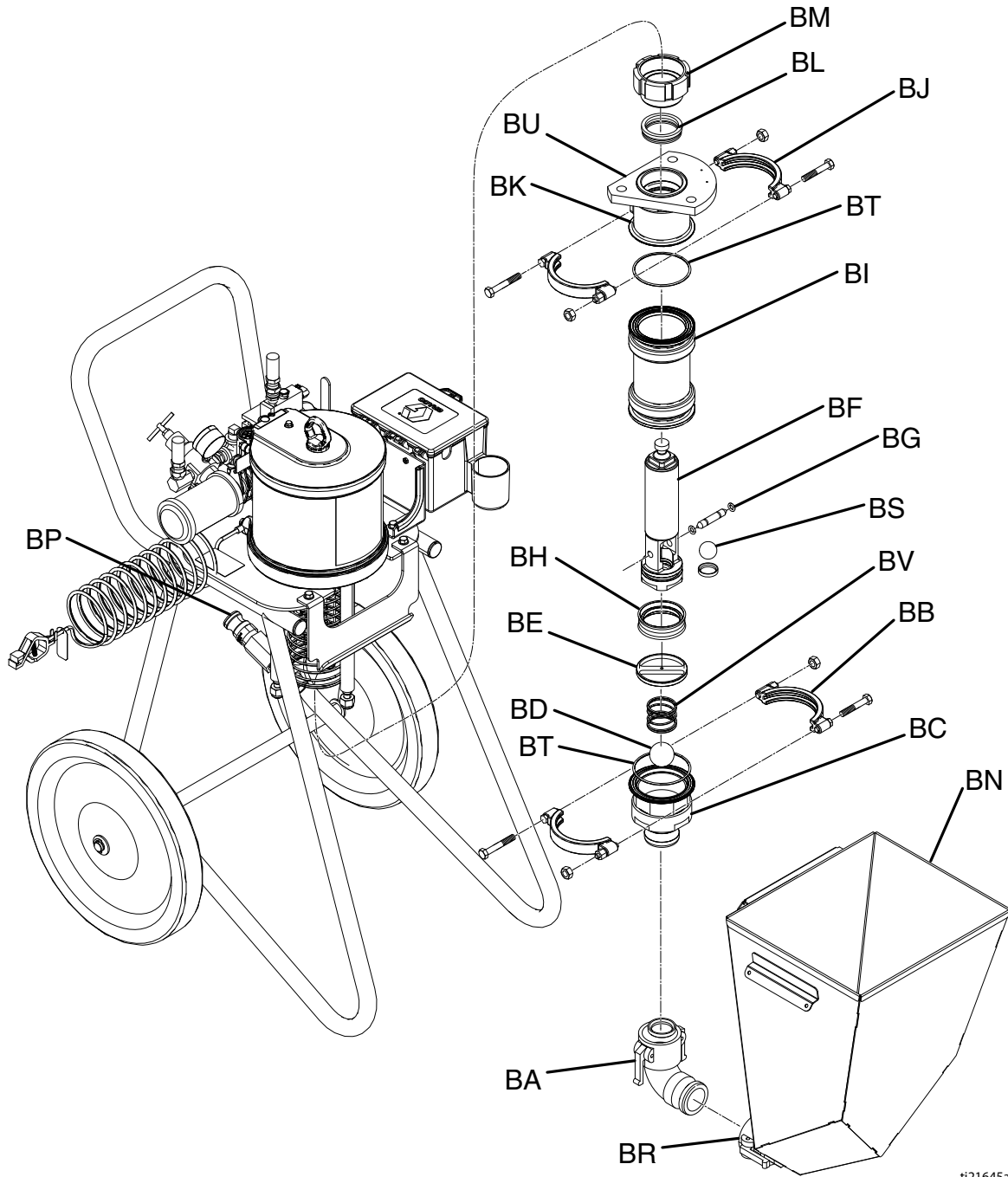

FIG. 37

Key

- BA Inlet Elbow with Camlock
- BB Inlet Housing Clamp
- BC Inlet Housing Assembly
- BD Inlet Ball
- BE Inlet Ball Stop
- BF Pump Rod Assembly
- BG Outlet Ball Stop
- BH Piston Seal
- BI Cylinder
- BJ Cylinder Clamp
- BK Outlet Housing
- BL Throat Packing
- BM Packing Nut (non-adjustable)
- BN Hopper
- BP Pump Outlet
- BR Hopper Release Camlock
- BS Outlet Ball
- BT Cylinder O-rings
- BU Outlet Housing Lock Nut
- BV Ball Cage Spring

Always Keep Spare Parts Stocked

Always keep spare parts stocked to ensure getting back up and running as quickly as possible. Parts to keep stocked include:

- Cam and groove fitting gaskets
- Spray tips
- Tip retainer
- Rod and cylinder seals
- Cylinder o-rings
- Other parts as needed



To prevent skin injection and splashing, never open a camlock hose or applicator fitting while there is pressure in the fluid line. See **Pressure Relief Procedure**, page 15.

See the figure at the beginning of this section for part references.

Disassemble and clean the pump at the end of every day. The procedure takes about 10 minutes.

NOTE: As items are disassembled, use a soft brush and water or a compatible solvent to clean components.

1. Flush the system. See **Flush**, page 27. Stop pump near bottom of its stroke.
2. Perform Pressure Relief Procedure. See **Pressure Relief Procedure**, page 15.
3. With fluid pressure relieved, remove material hose from pump outlet (BP).
4. Disconnect hopper at outlet camlock (BR) then remove hopper (BN).
5. Remove inlet elbow (BA).
6. Tip cart back so it rests on the back of the cart.

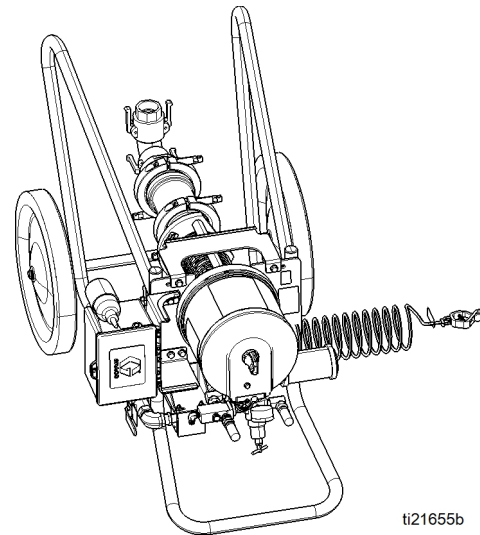

Fig. 38

7. While holding onto the inlet housing (BC), use a 5/8 in. wrench to loosen the two nuts on the inlet housing clamp (BB) then remove inlet housing (BC).
8. Remove inlet ball stop (BE) and ball cage spring (BV).
9. Use 5/8 in. wrench (64) to loosen the two nuts on the cylinder clamp (BJ) then remove cylinder (BI).

10. Disconnect pump rod (see the following figure):
 - a. Push piston rod protective spring up and away from coupling assembly (BF1-BF3).
 - b. Remove clip (BF1), and slide coupling cover (BF2) up to remove coupling (BF3).

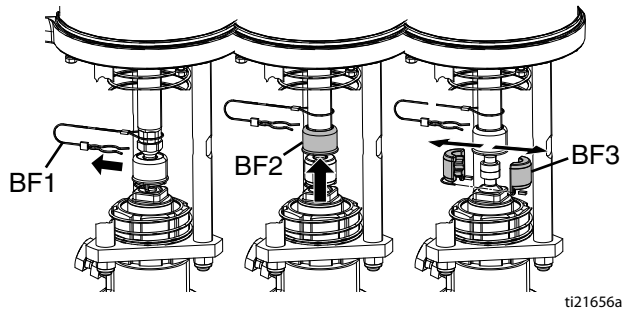

FIG. 39

11. Pull rod (BF) down and out of outlet housing (BK).
12. Remove outlet ball stop (BG) from rod (BF) by pushing o-rings off of ball stop (BG).
13. Loosen and remove packing nut (BM) then remove throat packing (BL).
14. Use a brush and solvent to clean all loose pieces.

NOTE: The pump rod (BF) is not disassembled unless the piston packing or seat needs to be replaced.

NOTE: The inlet housing (BC) is not disassembled unless the inlet seat needs to be replaced.

Assemble the Pump

1. Loosely install throat packing (BL) with the open end facing into the pump.
2. Install packing nut (BM) hand-tight.
3. Lubricate the balls (BS, BD) to ensure they do not stick.
4. Install outlet balls (BS), outlet ball stop (BG) with o-rings into rod (BF). Ensure outlet ball stop o-rings are in the grooves on the outlet ball stop rod.
5. Grease the packing on the rod (BF).
6. Gently slide rod (BF) through throat packing (BL).
7. Install coupling (BF3), slide coupling cover (BF2) over coupling, then install clip (BF1) to secure pump rod (BF) to air motor.

8. Use a flat-tip screwdriver and a plastic mallet to tighten packing nut (BM) until it stops.

NOTE: This is not an adjustable packing but the packing nut (BM) does need to be tight against the throat packing (BL).

9. Slide cylinder (BI) over rod (BF) with o-ring (BT) installed between outlet housing (BK) and cylinder (BI).

NOTE: If the o-ring (BT) does not stay in place while assembling the cylinder (BI) to the housing (BK), the cart may need to be tipped upright to install properly. After clamp is installed, tip cart back to horizontal position to finish assembly.

10. Use cylinder clamp (BJ) to secure cylinder (BI) to outlet housing (BK).

NOTE: Each clamp has one flat so that only one wrench is required to tighten clamp. Align bolt head with flat then use a wrench on the nut to tighten. Tighten both sides of the clamp evenly to approximately 10 ft-lb (14 N·m).

11. Install inlet ball (BD), ball cage spring (BV), and inlet ball stop (BE) in inlet housing (BC).

12. With inlet ball (BD), ball cage spring (BV), and inlet ball stop (BE) in place, place o-ring (BT) between cylinder (BI) and inlet housing (BC) then use inlet housing clamp (BB) to install inlet housing (BC) onto cylinder (BI).

NOTE: Each clamp has one flat so that only one wrench is required to tighten clamp. Align bolt head with flat then use a wrench on the nut to tighten. Tighten both sides of the clamp evenly to approximately 10 ft-lb (14 N·m).

13. Install inlet elbow (BA) onto inlet housing (BC).

14. Tip cart up.

15. Install hopper (BN) onto the hopper bracket and connect to inlet elbow (BA).

16. Install material hose into pump outlet (BP).

17. Wrap blue, velcro, camlock retaining straps around each camlock connection to secure.

NOTE: This includes the two camlocks between the hopper and pump lower, the camlock at the pump outlet, the camlocks on the fluid hoses, and the camlock on the applicator inlet. The retaining straps should be tight and must not be able to slide off camlock.

18. Add TSL to the packing nut (BM) until 1/2 full.

Shutdown



NOTICE

To prevent rust, never leave water or water-based fluid in pump overnight.

1. Flush the system. See **Flush**, page 27.

NOTE: If you are pumping water-based fluid, flush with water first, then with a rust inhibitor, such as mineral spirits solvent (also called white spirit), to prevent rust.

2. Perform Disassemble and Clean the Pump (Daily) procedure. See **Disassemble and Clean the Pump (Daily)**, page 30.

Maintenance

Preventative Maintenance

The operating conditions of your particular system determine how often maintenance is required

Establishing a preventative maintenance schedule by recording when and what kind of maintenance is needed, and then determine a regular schedule for checking your system.

Daily Maintenance



1. Flush the system. See **Flush**, page 27.
2. Relive pressure. See **Pressure Relief Procedure**, page 15.
3. Perform the Disassemble and Clean the Pump (Daily) procedure at the end of every day. See **Disassemble and Clean the Pump (Daily)**, page 30.
4. Drain water from air filter.

5. Clean hopper with a scrub pad. It is recommended that you clean the outside of the sprayer using a cloth and compatible solvent.
6. Check hoses, tubes, and couplings. Tighten all fluid connections before each use.
7. Check and replace camlock gaskets as needed.

Corrosion Protection

NOTICE

To prevent rust, never leave water on water-based fluid in pump overnight.

Always flush the pump before the fluid dries on the displacement rod. First, flush with water or a compatible solvent, then with oil. Relieve the pressure, but leave the oil in the pump to protect the parts from corrosion.

Cart Maintenance

Periodically lubricate the axle between points A and B with lightweight oil. See the following figure.

Keep the cart clean by wiping up spills daily, using compatible solvent.

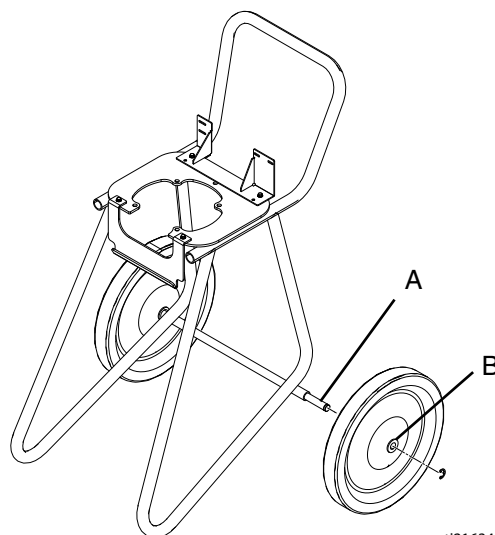

ti21634a

Troubleshooting



To prevent skin injection and splashing, never open a camlock hose or applicator fitting while there is pressure in the fluid line. See **Pressure Relief Procedure**, page 15.

1. Perform Pressure Relief Procedure. See **Pressure Relief Procedure**, page 15.
2. Check all possible problems, causes, and solutions listed below before disassembling pump.



PROBLEM - CAUSE - SOLUTION

Example:

- **Problem.**
 - *Cause.*
 - ◆ Solution.
- **Does not operate.**
 - *Air motor pilot valve (211) is faulty.*
 - ◆ Remove valve by disconnecting swivel unions. Connect hose directly to air motor. Operate motor directly with air regulator (210).
 - *Valve closed or clogged.*
 - ◆ Clear air line; increase air supply. Check that valves are open.
 - *Fluid hose or applicator obstructed.*
 - ◆ Clean hose or applicator.*
 - *Dried fluid on displacement rod or inlet ball.*
 - ◆ Clean rod; always stop pump at bottom of stroke; keep wet-cup filled with compatible solvent. Be sure inlet ball moves freely.
 - *Air motor parts dirty, worn or damaged.*
 - ◆ Clean or repair air motor. See motor manual.
- **Output low on both strokes.**
 - *Air line restricted or air supply inadequate. Valves closed or clogged.*
 - ◆ Clear air line; increase air supply. Check that valves are open.
 - *Fluid hose/applicator obstructed; hose ID too small.*
 - ◆ Clear hose or applicator*; use hose with larger ID.
- **Output low on down-stroke.**
 - *Open or worn intake valve.*
 - ◆ Clear or service intake valve.
- **Output low on up-stroke.**
 - *Open or worn piston valve or packings.*
 - ◆ Clear piston valve; replace packings.
- **Erratic accelerated speed.**
 - *Fluid supply exhausted, clogged suction.*
 - ◆ Refill hopper and prime pump.
 - *Open or worn piston valve or packings.*
 - ◆ Clear piston valve; replace packings.
 - *Open or worn intake valve.*
 - ◆ Clear or service intake valve.
- **Cycles or fails to hold pressure at stall.**
 - *Worn check balls, seats, or piston packing.*
 - ◆ Service lower. See **Disassemble and Clean the Pump (Daily)**, page 30.
- **Poor finish or irregular spray pattern.**
 - *Incorrect fluid pressure at applicator.*
 - ◆ See applicator manual; read fluid manufacturer's recommendations.
 - *Inadequate air assist air pressure.*
 - ◆ Adjust air assist needle valve.
 - *Dirty, worn, or damaged spray applicator.*
 - ◆ Service spray applicator. See spray applicator manual.
- **Cannot open or close air motor pilot ball valve on applicator.**
 - *Dirty air clogged the air motor pilot valve.*
 - ◆ If no ball valve is immediately available: Bypass the air motor pilot valve so air is always supplied to air motor, regardless of applicator pilot valve position. Then control fluid flow by adjusting air regulator pressure up and down as needed. Install new pilot ball valve when one becomes available.

- **Cannot open or close fluid ball valve on hose at applicator.**
 - *Mortar cured in valve due to insufficient flushing.*
 - ◆ If no ball valve immediately available: Relieve Pressure in system, remove ball valve, then control fluid flow by adjusting air regulator up and down as needed.
 - ◆ Disassembly, clean, and repack ball valve with lithium grease.
 - ◆ Replace ball valve.
 - **Motor powered but nothing comes out of hose.**
 - *Pump is packed out with dry or cured material.*
 - ◆ **Disassemble and Clean the Pump (Daily)**, page 30.
 - *Hose is packed out with dry or cured material.*
 - ◆ Reverse hose and try to push out bad material.
 - ◆ Some materials may need only 1 in. inner diameter fluid line all the way to the applicator.
 - **Material is too thick to push through hose without packing out.**
 - 3/4 in. x 10 ft whip hose is too restrictive.
 - ◆ Remove 3/4 in. x 10 ft whip hose from bundle at applicator end. Move fluid ball valve to end of 1 in. x 25 ft hose. Coil up extra air hose at machine end.
 - ◆ Thin and mix material thoroughly to a lower viscosity.
 - ◆ Use a pump system priming fluid (slime). See **Wet Out the System**, page 16.
- * To determine if fluid hose or applicator is obstructed, follow **Pressure Relief Procedure**, page 15. Disconnect fluid hose and place a container at pump fluid outlet to catch any fluid. Turn on air power just enough to start pump. If pump starts, the obstruction is in fluid hose or applicator.*

Repair

				
<p>To prevent skin injection and splashing, never open a camlock hose or applicator fitting while there is pressure in the fluid line. Pressure Relief Procedure, page 15, before performing any repair procedure.</p>				

Replace Pump Components

To replace any pump components (excluding the air motor), perform the **Disassemble and Clean the Pump (Daily)**, page 30.

Replace Air Motor

1. Perform **Pressure Relief Procedure**, page 15.
2. Note location of small air tube connections on air motor then remove air tubes.
3. Disconnect pump rod (see the following figure):
 - a. Push piston rod protective spring up and away from coupling assembly (BF1-BF3).
 - a. Remove clip (BF1), and slide coupling cover (BF2) up to remove coupling (BF3).

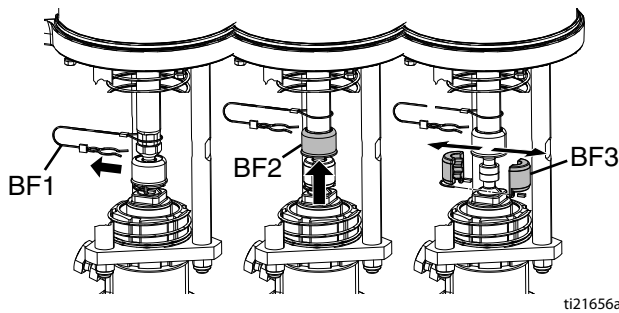

FIG. 40

4. Loosen three tie rod nuts (44), then loosen and remove tie rods (42) from air motor. See **Parts**, page 37.
5. Remove air motor.
6. Align air motor with tie rods (42) then tighten tie rods to air motor.
7. Tighten tie rod nuts (44).

8. Connect pump rod. See figure shown previously in this section.
9. Connect small air tubes to air motor.

Replace Pump Lower.

Perform this procedure to replace the entire pump lower with a new or different pump lower. To repair or replace any internal components in the pump (excluding the air motor), perform **Disassemble and Clean the Pump (Daily)**, page 30.

1. Perform **Pressure Relief Procedure**, page 15.
2. Disconnect pump lower from hopper.
3. Disconnect material hose from pump lower outlet.
4. Disconnect pump rod (see the following figure):
 - a. Push piston rod protective spring up and away from coupling assembly (BF1-BF3).
 - b. Remove clip (BF1), and slide coupling cover (BF2) up to remove coupling (BF3).

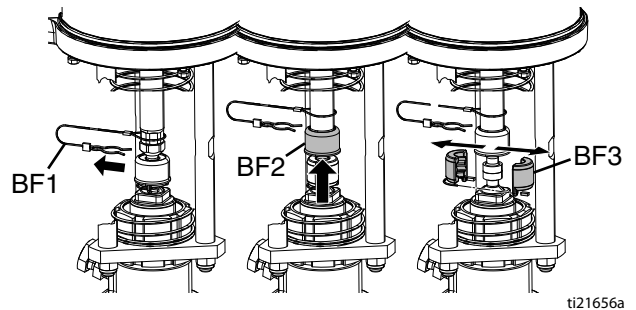
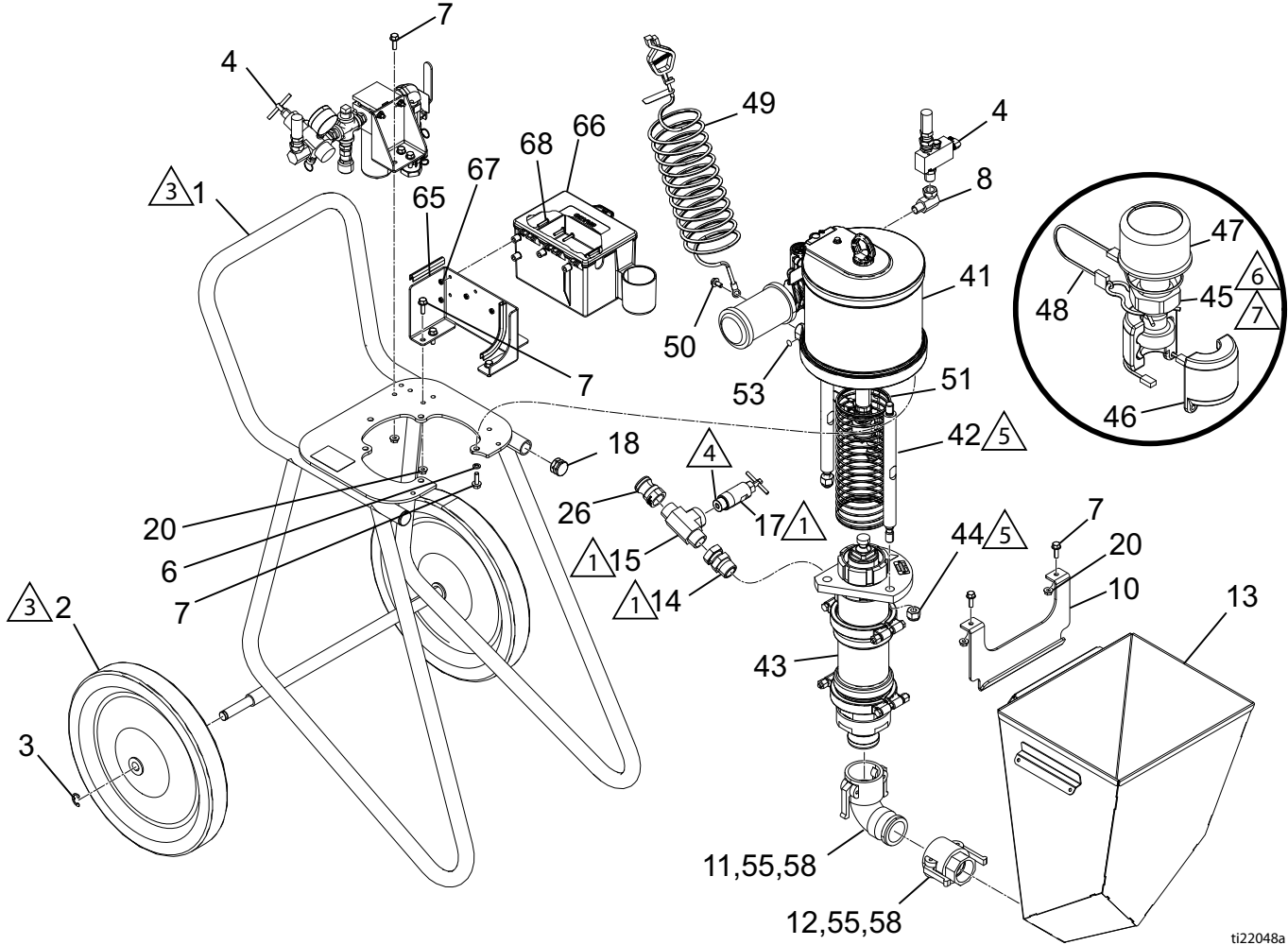

FIG. 41

5. Loosen three tie rod nuts (44), then loosen and remove tie rods (42) from air motor. See **Parts**, page 37.
6. Remove pump lower.
7. Align new pump lower with tie rods (42) then tighten tie rods to air motor.
8. Tighten tie rod nuts (44).
9. Connect pump rod. See figure shown previously in this section
10. Connect pump lower to hopper.

Parts

ToughTek M680a Systems



ti22048a

- 1** Assemble fitting (15) and zero cavity relief valve (17) then assemble to swivel (14) with relief hole pointing downward or at the pump.
- 2** Apply pipe sealant to all non-swiveling pipe threads.
- 3** Apply clear, liquid petrolatum to axles (1) before assembling wheels (2).

- 4** Pack grease around the end of the zero-cavity relief valve in front of the threads.
- 5** Torque to 50-60 ft-lb (68-81 N·m).
- 6** Torque to 145-155 ft-lb (197-210 N·m).
- 7** Apply medium strength thread-locking fluid to threads.

Ref.	Part	Description	Quantity						
			24T834	24T835	24T836	24T837	262909	262926	262927
1	262914	CART	1	1	1	1	1	1	1
2	116406	WHEEL	2	2	2	2	2	2	2
3	113436	RING, retaining	2	2	2	2	2	2	2
4	- - -	MODULE, air controls; see Air Controls	1	1	1	1	1	1	1
6	104572	WASHER, lock spring	4	4	4	4	4	4	4
7 ★	114193	SCREW, machine, hex washer head	12	10	12	10	12	10	12
8	155470	SWIVEL, union 90 degrees	1	1	1	1	1	1	1
10 ★	- - -	BRACKET, hopper	1		1		1		1
11 ★	16V510	CAM AND GROOVE, elbow, 2 in.	1		1		1		1
12 ★	16V509	CAM AND GROOVE, 2 in. x 1-1/2 npt	1		1		1		1
13 ★	16U536	HOPPER	1		1		1		1
14	160022	UNION, adapter	1	1	1	1	1	1	1
15	127082	TEE, branch, female	1	1	1	1	1	1	1
17	16W513	VALVE, relief, zero cavity	1	1	1	1	1	1	1
18	- - -	PLUG, tubing, cart	2	2	2	2	2	2	2
20 ★	- - -	NUT, hex, flange, serrated	8	6	8	6	8	6	8
29	114958	STRAP, tie	10	10			10	10	10
30	110198	COUPLER, line, air	1	1			1	1	2
31	159841	BUSHING, 3/8 x 1/4 in.	1	1			1	1	2
32	169970	FITTING, line air	1	1			1	1	2
33	24U209	APPLICATOR, texture, pole					1	1	2
34	24T947	APPLICATOR, texture, flexible	1	1					1
41 ♦	M34LN0	MOTOR, air	1	1	1	1	1	1	1
42 ♦	16U817	ROD, tie, 10-5/8	3	3	3	3	3	3	3
43 ♦	24R253	LOWER, pump (see manual 332649)	1	1	1	1	1	1	1
44 ♦	101712	NUT, lock	3	3	3	3	3	3	3
45 ♦	15H392	ROD, adapter	1	1	1	1	1	1	1
46 ♦	244819	COUPLING, assembly	1	1	1	1	1	1	1
47 ♦	197340	COVER, coupler	1	1	1	1	1	1	1
48 ♦	244820	CLIP, hairpin with lanyard	1	1	1	1	1	1	1
49 ♦	262908	WIRE, ground, with clamp	1	1	1	1	1	1	1
50 ♦	111799	SCREW, cap, hex head	1	1	1	1	1	1	1
51 ♦	16V671	GUARD, spring	1	1	1	1	1	1	1
53 ▲	186620	LABEL, symbol, ground	1	1	1	1	1	1	1
55**	16W506	GASKET, 2 in., coupler, cam and groove (6-pack)	2		2		2		2
57**	16W490	O-RING, pump cylinder (10-pack)	2	2	2	2	2	2	2
59**	16A443	NOZZLE, 3/16 in.							1
60	16A444	NOZZLE, 1/4 in.							1

Ref.	Part	Description	Quantity						
			24T834	24T835	24T836	24T837	262909	262926	262927
61**	16A448	NOZZLE, 1/2 in.							1
62**	16A449	NOZZLE, 9/16 in.							1
63**	16W508	KIT, seals, pumps							1
64**	127265	TOOL, wrench, ratchet	1	1	1	1	1	1	1
65	- - -	BRACKET, tool box	1	1	1	1	1	1	1
66	- - -	KIT, tool box	1	1	1	1	1	1	1
67	113505	NUT, keps, hex head	4	4	4	4	4	4	4
68	107251	SCREW, machine, panhead	4	4	4	4	4	4	4
98	24T854	BUNDLE, hose, 35 ft	1	1			1	1	1
99	24R254	BUNDLE, hose, extension, 25 ft							1

▲	<i>Replacement Danger and Warning labels, tags, and cards are available at no cost.</i>
★	<i>Parts included in Hopper Replacement Kit 24T853 (purchase separately).</i>
◆	<i>Parts included in Pump 16W514 (purchase separately). See manual 332650.</i>
**	<i>Spare parts shipped with machine.</i>
- - -	<i>Not for sale.</i>

Air Controls

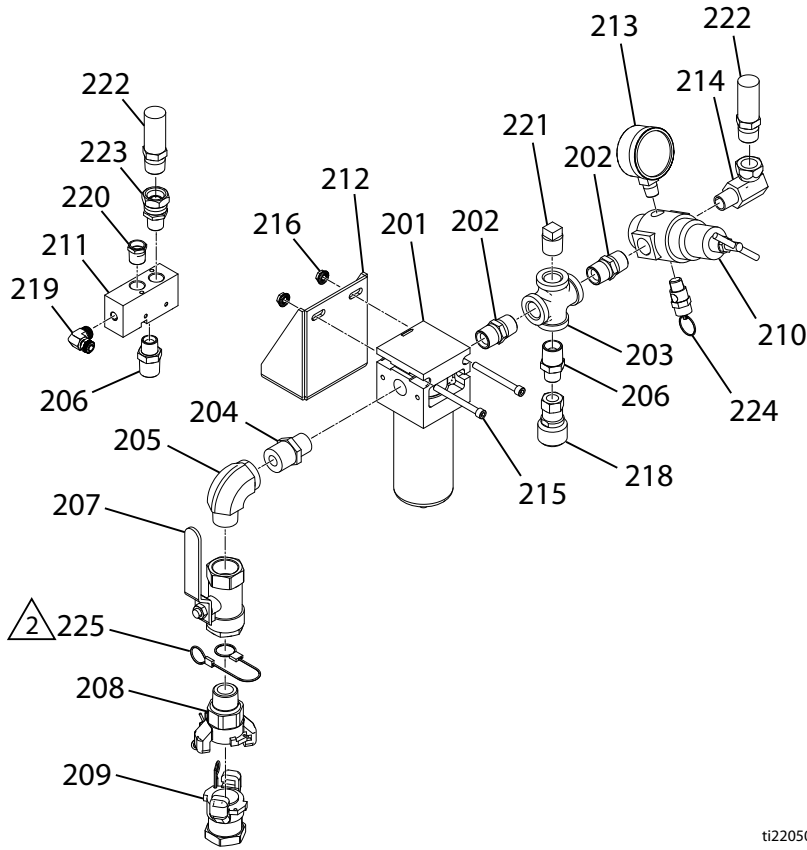

ti22050a

1 Apply pump sealant to all non-swiveling pipe threads.

2 Assemble one end of lanyard between ball valve (207) and fitting (208). One end hangs loose.

Ref.	Part	Description	Qty
201	262658	FILTER, air, 40 micron	1
202	158491	FITITNG, nipple	2
203	C20432	FITITNG, cross, pipe	1
204	C20461	FITTING, nipple, reducing, hex	1
205	- - -	FITTING, elbow, street	1
206	159239	FITTING, nipple, pipe, reducing	2
207	113332	VALVE, ball, vented, 0.750	1
208	113429	COUPLING, universal, 3/4-14 npt male	1
209	113430	COUPLING, universal, 3/4-14 npt female	1
210	104267	REGULATOR, air	1
211	16W146	VALVE, 3-way, pilot operated	1
212	- - -	BRACKET, air controls	1

Ref.	Part	Description	Qty
213	160430	GAUGE, pressure, air	1
214	155470	FITTING, swivel, union, 90 degree	1
215	101950	SCREW, socket head cap, 1/4 x 2.5 in.	2
216	115942	NUT, hex, flange head	2
218	110198	COUPLER, line, air	1
219	127313	FITTING, elbow	1
220	111881	MUFFLER	1
221	100737	PLUG, pipe	1
222	218093	HOSE, coupled	1
223	162505	FITITNG, union, swivel	1
224	113498	VALVE, safety, 100 psi	1
225	16W586	CABLE, lanyard, whip check	1

- - - Not for sale.

Zero Cavity Relief Valve, 16W513

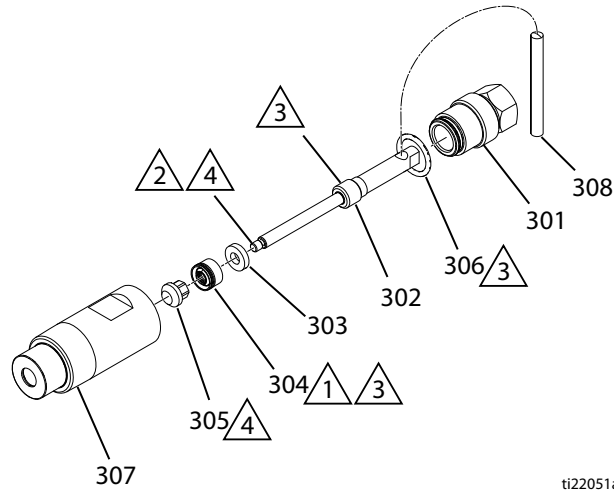

ti22051a



Use assembly tool 15T630 to install seal (304).



Apply lithium grease to seal, thread, and o-ring.



Apply medium strength thread-locking fluid to threads prior to installing seat (305).



Torque to 95-105 in-lb (10.7-11.9 N·m).

Ref.	Part	Description	Qty
301	- - -	HOUSING, end	1
302	16U807	STEM	1
303	15M189	SPACER, backup, seal	1
304	15M529	SEAL, check valve	1

Ref.	Part	Description	Qty
305	16V956	SEAT	1
306	15Y627	O-RING, PTFE	1
307	16V957	HOUSING	1
308	102915	PIN, drive	1

- - - *Not for sale.*

Hose Bundles

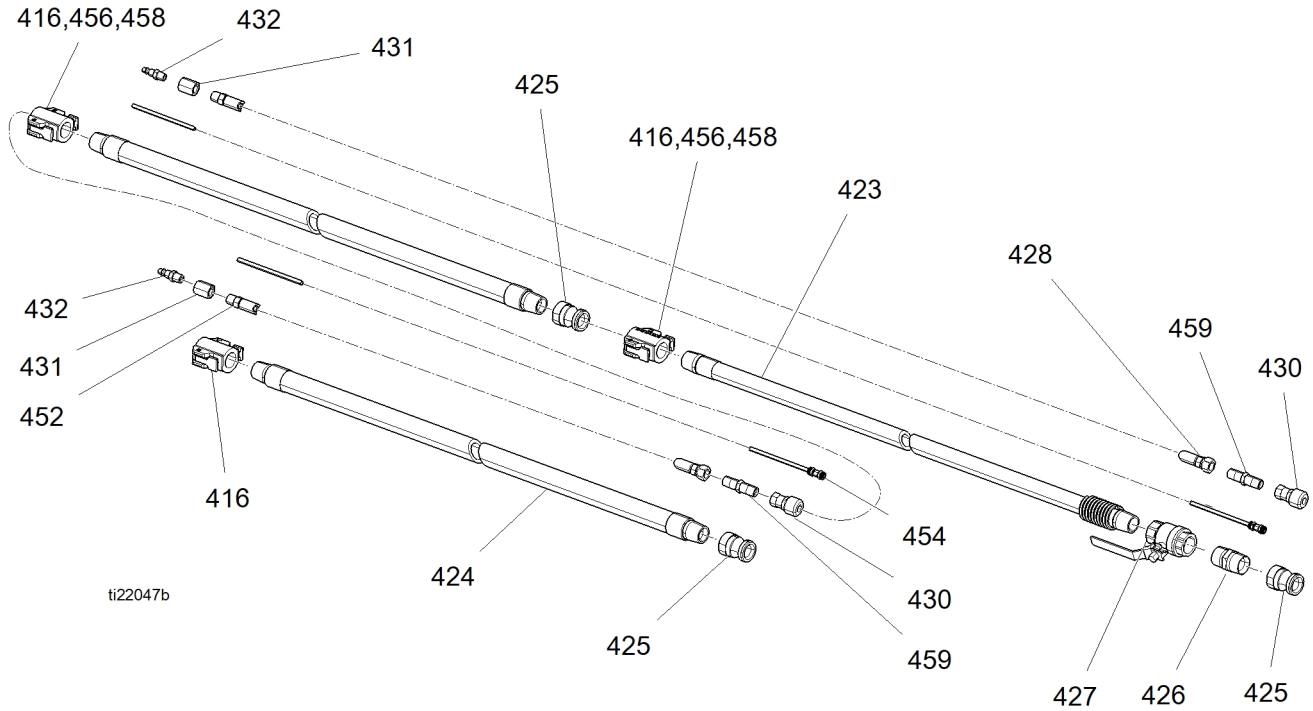

Ref.	Part	Description	Quantity			
			24T854 (35 ft bundle)	24R254 (25 ft bundle)	24U331 (38 ft air hose bundle)	24T852 (25 ft air hose bundle)
416	289874	COUPLER KIT, 1 in. female cam/groove	2	1		
421	24U184	COVER, hose, plastic, 2 in. x 50 ft	1	1		
422	24U185	COVER, hose, plastic, 3 in. x 50 ft	1	1	1	1
423	16W512	HOSE, fluid, 3/4 in., coupled, 10 ft	1			
424	16W511	HOSE, fluid, 1 in., coupled 25 ft	1	1		
425*	15T116	COUPLER, male, cam and groove, 1 in.	2	1		
426*	158585	FITTING, nipple	1	1		
427	127232	VALVE, ball, 1 in., stainless steel, 1000 psi	1	1		
428	24T762	HOSE, air and pilot in scuff jacket, 38 ft	1		1	
429	114958	STRAP, tie	10	10		
430	110198	COUPLER, line, air	1	1	1	1
431	100083	COUPLING, 3/8 x 1/4 in.	1	1	1	1
432	169970	FITTING, line air	1	1	1	1
452	24T829	HOSE, bundle, air, 26 ft		1		1
454	127312	FITTING, 1/4 to 1/4 tube	1	1	1	1
456	16W507	GASKET, coupler, 1 in. (6-pack)	2	2		
458	240296	STRAP (4-pack)	2	2		
459	156850	FITTING, nipple, 3/8 npt	1	1	1	1

* Parts included in Pack Out Hose Clean Kit 16W601 (purchase separately).

Accessories

Pole Applicator, 24T946

Ideal for spraying in long-reach, open areas and low-pressure spraying of materials that packout easily and that will be finished-troweled. The pole applicator is similar to the Flexible Applicator, but with a pipe in place of the hose. See manual 332767.

Includes:

- 30 in. (76 cm) aluminum pipe with camlock fluid inlet
- Angled spray head
- Spray air volume control
- Spray shut-off valve
- Motor pilot signal control valve
- Adjustable position center air injection tube
- Rubber tip retainer
- 4 different-sized tips

Technical Specifications

Mortar and Epoxy Sprayer Package		
	U.S.	Metric
Maximum Working Pressure	1000 psi	7 MPa, 70 bar
Maximum Air Inlet Pressure	100 psi	0.7 MPa, 7 bar
Minimum Inlet Air Flow (Typical)	30 standard cubic feet per minute	0.85 cubic meters per minute
Minimum Inlet Air Flow (Pump Only)	8 scfm per gallon at 100 psi	0.06 cubic meters per minute per liter at 7 bar
Pressure Ratio (Fluid to Air)	10:1	
Air Motor Piston Diameter	7.5 in.	191 mm
Stroke Length	4.75 in.	120 mm
Lower Output	41.9 cu. in. per cycle	686 cc per cycle
Flow Rate at 30 cycles per minute	5.44 gpm	20.6 lpm
Flow Rate at 60 cycles per minute	10.88 gpm	41.2 lpm
Air Inlet Size	3/4 npt(f) (Chicago Fitting)	
Fluid Inlet Size	2 in. Cam Groove (Male)	
Fluid Outlet Size	1 npt(f) with a 1 in. Cam and Groove Fitting	
Weight (without fluid)	250 lb (with 25 ft of 1 in. hose and 10 ft of 3/4 in. hose)	113 kg (with 7.6 m of 25 mm hose and 3.0 m of 19 mm hose)
Sound Pressure	118 dB(A)*	
Sound Power	118 dB(A)*	
Dimensions		
Height	44.5 in.	113 cm
Width	27.5 in.	70 cm
Depth (pump on cart only)	32 in.	81 cm
Deep (pump on cart with hopper)	37 in.	94 cm
Maximum Pump Speed		
(Do not exceed maximum recommended pump speed of fluid pump to prevent premature pump wear)		
Spraying	40 cycles per minute (typically less than 10 cycles per minute)	
Flushing	60-90 cycles per minute (only when pumping flushing fluid)	
Wetted Parts		
Entire System	Stainless steel, UHMWPE, nylon, plated steel, anodized aluminum, FX-75	
Pump	Stainless steel, carbide, PTFE, UHMWPE, solvent-resistant o-rings	
Hose Kits	Nylon core, plated carbon steel fittings, anodized aluminum, nitrile gaskets	
Notes		
* Spraying simulated acoustical texture under typical conditions as specified by the material manufacturer.		

**ToughTek M680a Performance Chart
(with 30-weight oil)**
Pump Cycle Per Minute

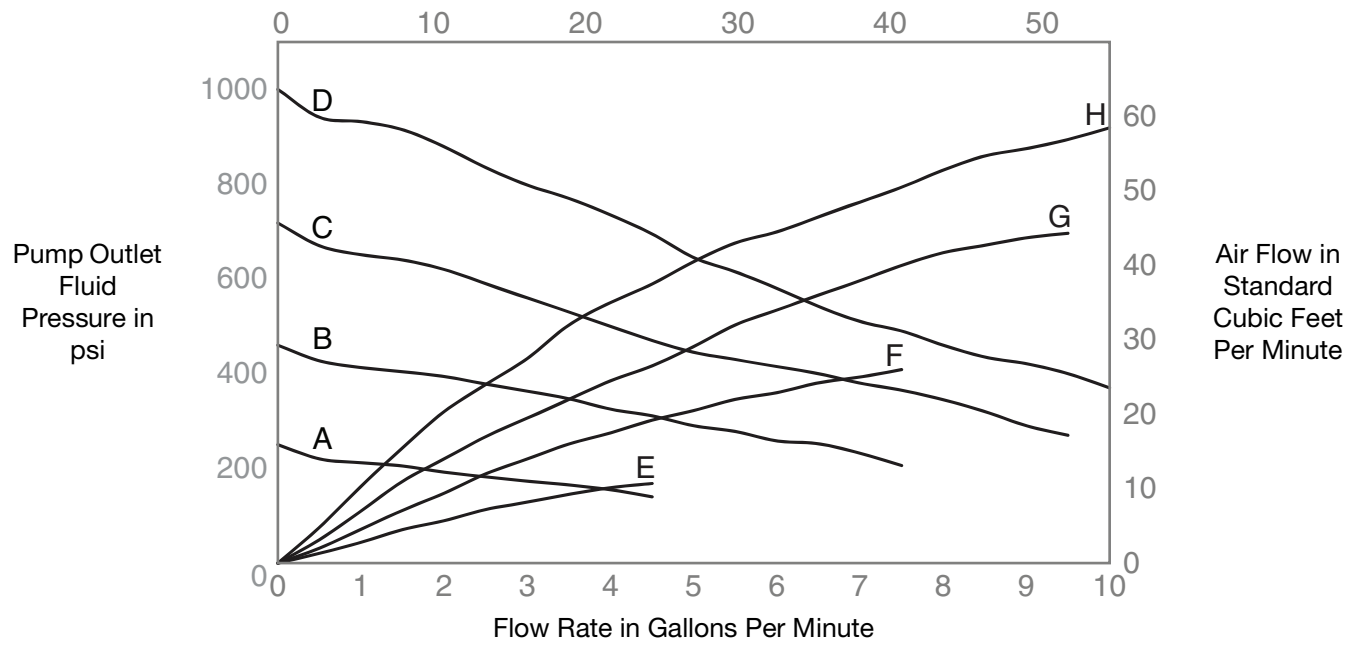

Ref	Description
A	Fluid Pressure at 20 psi Air
B	Fluid Pressure at 40 psi Air
C	Fluid Pressure at 70 psi Air
D	Fluid Pressure at 100 psi Air
E	Air Consumption at 20 psi Air
F	Air Consumption at 40 psi Air
G	Air Consumption at 70 psi Air
H	Air Consumption at 100 psi Air

ToughTek M680a Applicator Air Consumption
(100 psi feed to the machine)

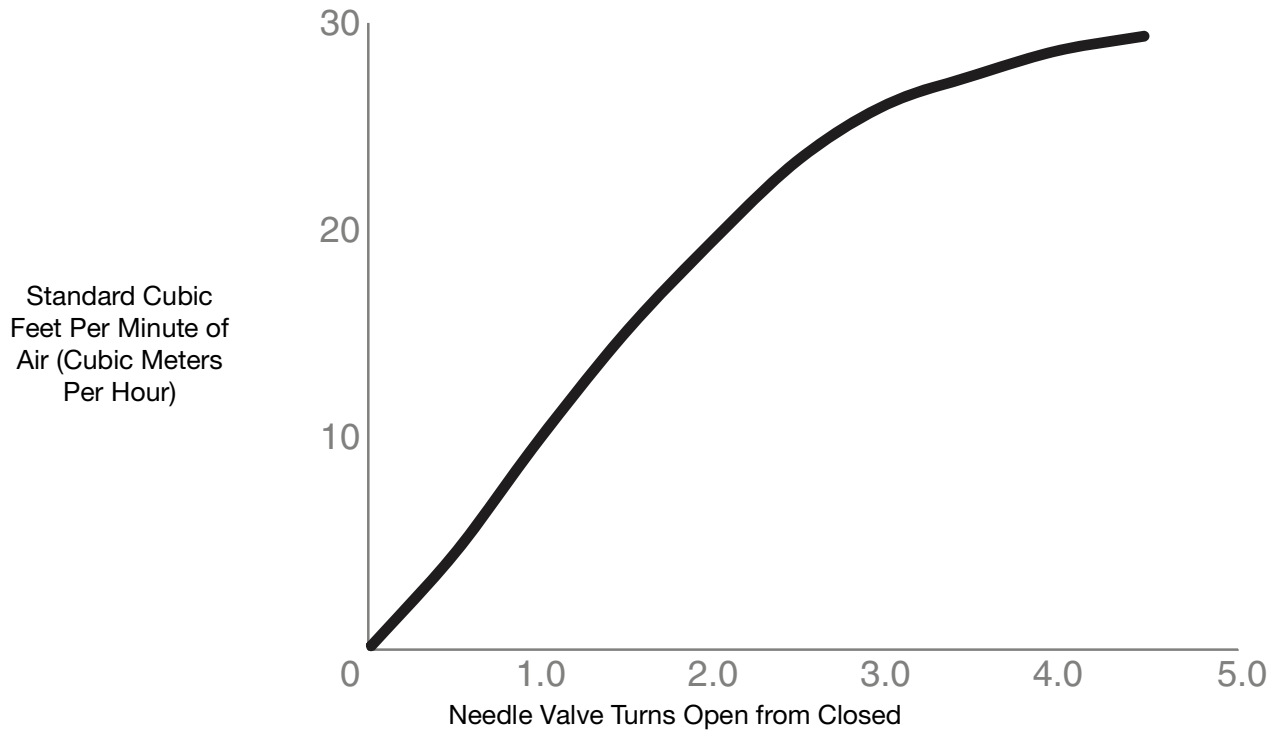

Graco Standard Warranty

Graco warrants all equipment referenced in this document which is manufactured by Graco and bearing its name to be free from defects in material and workmanship on the date of sale to the original purchaser for use. With the exception of any special, extended, or limited warranty published by Graco, Graco will, for a period of twelve months from the date of sale, repair or replace any part of the equipment determined by Graco to be defective. This warranty applies only when the equipment is installed, operated and maintained in accordance with Graco's written recommendations.

This warranty does not cover, and Graco shall not be liable for general wear and tear, or any malfunction, damage or wear caused by faulty installation, misapplication, abrasion, corrosion, inadequate or improper maintenance, negligence, accident, tampering, or substitution of non-Graco component parts. Nor shall Graco be liable for malfunction, damage or wear caused by the incompatibility of Graco equipment with structures, accessories, equipment or materials not supplied by Graco, or the improper design, manufacture, installation, operation or maintenance of structures, accessories, equipment or materials not supplied by Graco.

This warranty is conditioned upon the prepaid return of the equipment claimed to be defective to an authorized Graco distributor for verification of the claimed defect. If the claimed defect is verified, Graco will repair or replace free of charge any defective parts. The equipment will be returned to the original purchaser transportation prepaid. If inspection of the equipment does not disclose any defect in material or workmanship, repairs will be made at a reasonable charge, which charges may include the costs of parts, labor, and transportation.

THIS WARRANTY IS EXCLUSIVE, AND IS IN LIEU OF ANY OTHER WARRANTIES, EXPRESS OR IMPLIED, INCLUDING BUT NOT LIMITED TO WARRANTY OF MERCHANTABILITY OR WARRANTY OF FITNESS FOR A PARTICULAR PURPOSE.

Graco's sole obligation and buyer's sole remedy for any breach of warranty shall be as set forth above. The buyer agrees that no other remedy (including, but not limited to, incidental or consequential damages for lost profits, lost sales, injury to person or property, or any other incidental or consequential loss) shall be available. Any action for breach of warranty must be brought within two (2) years of the date of sale.

GRACO MAKES NO WARRANTY, AND DISCLAIMS ALL IMPLIED WARRANTIES OF MERCHANTABILITY AND FITNESS FOR A PARTICULAR PURPOSE, IN CONNECTION WITH ACCESSORIES, EQUIPMENT, MATERIALS OR COMPONENTS SOLD BUT NOT MANUFACTURED BY GRACO. These items sold, but not manufactured by Graco (such as electric motors, switches, hose, etc.), are subject to the warranty, if any, of their manufacturer. Graco will provide purchaser with reasonable assistance in making any claim for breach of these warranties.

In no event will Graco be liable for indirect, incidental, special or consequential damages resulting from Graco supplying equipment hereunder, or the furnishing, performance, or use of any products or other goods sold hereto, whether due to a breach of contract, breach of warranty, the negligence of Graco, or otherwise.

FOR GRACO CANADA CUSTOMERS

The Parties acknowledge that they have required that the present document, as well as all documents, notices and legal proceedings entered into, given or instituted pursuant hereto or relating directly or indirectly hereto, be drawn up in English. Les parties reconnaissent avoir convenu que la rédaction du présente document sera en Anglais, ainsi que tous documents, avis et procédures judiciaires exécutés, donnés ou intentés, à la suite de ou en rapport, directement ou indirectement, avec les procédures concernées.

Graco Information

For the latest information about Graco products, visit www.graco.com.

For patent information, see www.graco.com/patents.

TO PLACE AN ORDER, contact your Graco distributor or call to identify the nearest distributor.

Toll Free Phone Number: 1-800-328-0211

*All written and visual data contained in this document reflects the latest product information available at the time of publication.
Graco reserves the right to make changes at any time without notice.*

Original instructions. This manual contains English. MM 332612

Graco Headquarters: Minneapolis

International Offices: Belgium, China, Japan, Korea

GRACO INC. AND SUBSIDIARIES • P.O. BOX 1441 • MINNEAPOLIS MN 55440-1441 • USA
Copyright 2013, Graco Inc. All Graco manufacturing locations are registered to ISO 9001.

www.graco.com
Revision D, October 2024