

## Single Acting and Double Acting Paint Spray Guns for RoadLazer™ RoadPak™ Line Striping System

308613N

EN

- For the application of road marking paints and coatings -  
- For professional use only -

**Model: 238377 (Single-acting gun)**

**Model: 24G980 (Double-acting gun)**

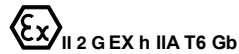

Maximum Working Pressure 3000 psi (21 MPa, 210 bar)



### Important Safety Instructions

Read all warnings and instructions in this manual. Save these instructions.

238377

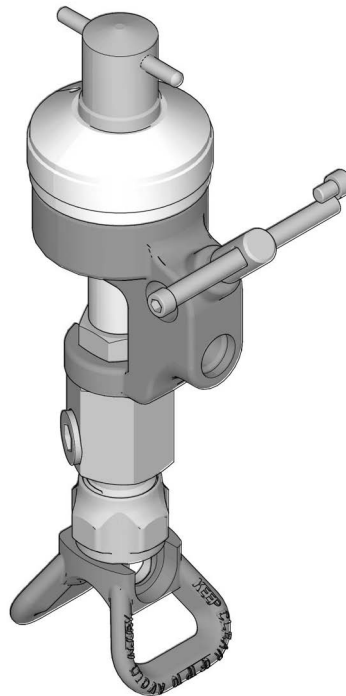

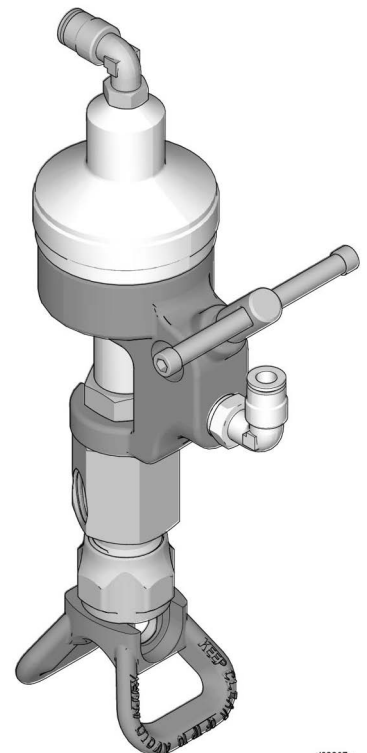

24G980



t133207a

# Warnings

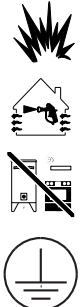
The following warnings are for the setup, use, grounding, maintenance, and repair of this equipment. The exclamation point symbol alerts you to a general warning and the hazard symbols refer to procedure-specific risks. When these symbols appear in the body of this manual, refer back to these Warnings. Product-specific hazard symbols and warnings not covered in this section may appear throughout the body of this manual where applicable.

 <span style="font-size: 2em; font-weight: bold; margin-left: 10px;">WARNING</span>	
	<p><b>FIRE AND EXPLOSION HAZARD</b></p> <p>Flammable fumes, such as solvent and paint fumes, in work area can ignite or explode. To help prevent fire and explosion:</p> <ul style="list-style-type: none"> <li>• Do not spray flammable or combustible materials near an open flame or sources of ignition such as cigarettes, motors, and electrical equipment.</li> <li>• Paint or solvent flowing through the equipment is able to result in static electricity. Static electricity creates a risk of fire or explosion in the presence of paint or solvent fumes. All parts of the spray system, including the pump, hose assembly, spray gun, and objects in and around the spray area shall be properly grounded to protect against static discharge and sparks. Use Graco conductive or grounded high-pressure airless paint sprayer hoses.</li> <li>• Do not clean with materials having flash points lower than 70° F (21° C). Use water-based material or mineral spirits-type material only. For complete information about your fluid, request the MSDS from the fluid distributor or retailer.</li> <li>• Verify that all containers and collection systems are grounded to prevent static discharge.</li> </ul>
	<p><b>SKIN INJECTION HAZARD</b></p> <p>High-pressure fluid from dispensing device, hose leaks, or ruptured components will pierce skin. This may look like just a cut, but it is a serious injury that can result in amputation. <b>Get immediate surgical treatment.</b></p> <ul style="list-style-type: none"> <li>• Do not point dispensing device at anyone or at any part of the body.</li> <li>• Do not put your hand over the fluid outlet.</li> <li>• Do not stop or deflect leaks with your hand, body, glove, or rag.</li> <li>• Follow the <b>Pressure Relief Procedure</b> when you stop dispensing and before cleaning, checking, or servicing equipment.</li> <li>• Tighten all fluid connections before operating the equipment.</li> <li>• Check hoses and couplings daily. Replace worn or damaged parts immediately.</li> </ul>

# WARNING



## EQUIPMENT MISUSE HAZARD

Misuse can cause death or serious injury.



- Do not operate the unit when fatigued or under the influence of drugs or alcohol.
- Do not exceed the maximum working pressure or temperature rating of the lowest rated system component. See **Technical Data** in all equipment manuals.
- Use fluids and solvents that are compatible with equipment wetted parts. See **Technical Data** in all equipment manuals. Read fluid and solvent manufacturer's warnings. For complete information about your material, request MSDS from distributor or retailer.
- Do not leave the work area while equipment is energized or under pressure. Turn off all equipment and follow the **Pressure Relief Procedure** when equipment is not in use.
- Check equipment daily. Repair or replace worn or damaged parts immediately with genuine manufacturer's replacement parts only.
- Do not alter or modify equipment.
- Use equipment only for its intended purpose. Call your distributor for information.
- Route hoses and cables away from traffic areas, sharp edges, moving parts, and hot surfaces.
- Do not kink or over bend hoses or use hoses to pull equipment.
- Keep children and animals away from work area.
- Comply with all applicable safety regulations.



## TOXIC FLUID OR FUMES HAZARD

Toxic fluids or fumes can cause serious injury or death if splashed in the eyes or on skin, inhaled, or swallowed.

- Read MSDSs to know the specific hazards of the fluids you are using.
- Store hazardous fluid in approved containers, and dispose of it according to applicable guidelines.

# Installation

Accessories are available from Graco. Be sure all accessories are properly sized to withstand the pressures in the system.

## Mount Valve

Mount the valve on a 0.50 in. (12.7 mm) diameter rod on a mounting fixture or a dispensing machine. The paint gun has a clamping set screw (6) for mounting.

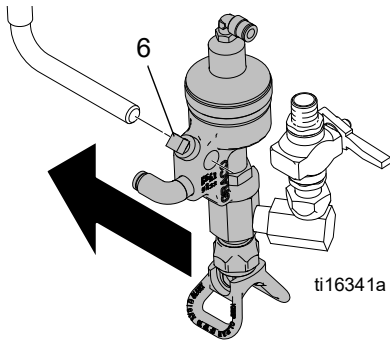

## Connect the Air Lines

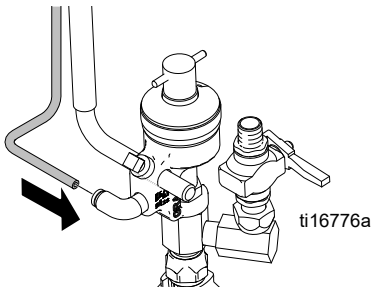

Single-Acting Gun

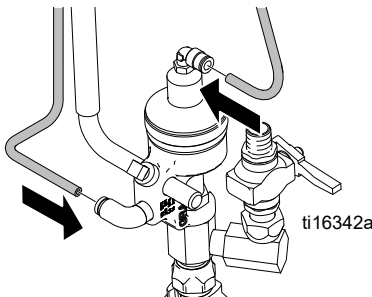

Double-Acting Gun

Clean all lines and connections of dirt, burrs, etc. and blow them out with clean air before connecting them to the system. Install an air filter in the air supply line to remove harmful dirt and moisture from the compressed air.

## Connect Fluid Lines

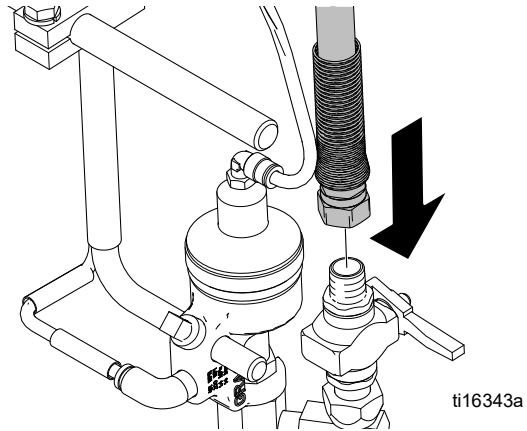

Connect a grounded fluid line from the pump to the fluid adapter of the paint spray gun. You should install a fluid pressure regulator to control fluid pressure to the paint spray gun. The regulator enables you to control fluid pressure more accurately than by regulating hydraulic pressure to the pump.

Install a fluid filter to remove particles and sediment which may clog the tip.

Install a manual ball valve to shut off fluid flow to spray gun.

## Grounding

Proper grounding is essential to maintaining a safe system.

To reduce the risk of static sparking, ground the pump, paint spray gun, and all other system equipment.

1. **Pump:** Use a ground wire and clamp.
2. **Air compressors and hydraulic power supplies:** Follow manufacturer's recommendations.
3. **Air and fluid hoses connected to the pump:** Use only grounded hoses with a maximum of 500 feet (150 m) combined hose length to ensure grounding continuity.
4. **Dispensing valve:** Obtain grounding through connection to a properly grounded fluid hose and pump.
5. **Fluid supply container:** According to local code.
6. **All solvent pails used when flushing:** Ground according to local code. *Use only metal pails*, which are conductive. Do not place the pail on a non-conductive surface, such as paper or cardboard, which interrupts the grounding continuity.



# Operation

## Adjustments

Set the actuating air to at least 75 psi (5.2 bar) and start the pump. Set the pump speed and pressure to obtain the desired flow rate. Always use the lowest pump speed necessary to achieve desired results.

1. Shut off the power to the pump.
2. Close the bleed-type master air valve (required with air-powered pumps).
3. Actuate the dispensing valve to relieve pressure.
4. Open the pump drain valve (required in your system) to help relieve fluid pressure in the displacement pump. Actuating the dispensing valve to relieve pressure may not be sufficient. Have a container ready to catch the drainage.
5. Leave the drain valve(s) open until you are ready to dispense again.

## Pressure Relief Procedure

					
<b>FLUID INJECTION HAZARD</b>					
To reduce the risk of serious bodily injury, including fluid injection, splashing in the eyes or on the skin, or injury from moving parts, always follow this procedure whenever you shut off the pump, when checking or servicing any part of the dispensing system, when installing, cleaning, or changing part of the valve and whenever you stop dispensing.					

If you suspect that the dispensing valve or hose is completely clogged, or that pressure has not been fully relieved after following the steps above, **very slowly** loosen the hose end coupling and relieve pressure gradually, then completely loosen. Then clear the valve or hose.

## Application Data

APPLICATION RECOMMENDATIONS*	TRAVEL SPEED IN MILES PER HOUR (KPH)									
	Based on 15 mils (.381 mm) wet paint									
	3 (5)	4 (6)	5 (8)	6 (10)	7 (11)	8 (12)	9 (14)	10 (16)	11 (18)	12 (19)
<b>Paint Tip Size</b>										
For a 4 inch (101 mm) wide line	433 LL5333	433 LL5333	439	439	443 LL5343	443 LL5343	445	449	453	457
For a 6 inch (152 mm) wide line	539 LL5439	539 LL5439	543 LL5443	549	559	561	565			
For a 12 inch (304 mm) wide line	643	649								
<b>Operating Pressure psi (bar)</b>										
Paint System	1500-2000 (102)	1500-2000 (102)	1500-2000 (102)	1500-2000 (102)	1500-2000 (102)	1500-2000 (102)	1500-2000 (102)	1500-2000 (102)	1500-2000 (102)	1500-2000 (102)

\* Coverage may vary depending on paint used.

# Maintenance

## Clean Dispensing Valve and System Daily

**NOTICE**  
Be sure that the solvent you use is compatible with the fluid being dispensed to avoid clogging the fluid passages in the valve.

An important part of the care and maintenance of your automatic dispensing valve is proper flushing. Flush the valve daily with a compatible solvent until all traces of fluid are removed from the valve passages. Perform **Pressure Relief Procedure**, page 5 before flushing.

Clean the outside surfaces of the valve by wiping with a soft cloth dampened with a compatible solvent.

**NOTICE**  
Never immerse the entire dispensing valve in solvent. Immersing in solvent removes lubricants and can damage packings.

To remove a hardened particle from the orifice, blow air through the orifice from the front.

## Oil Dispensing Valve Daily

Before each use, lubricate with a spray of oil inside the protection tube (13) to prevent fluid buildup on these parts. Any buildup could damage the valve packings (16, 17, 18).

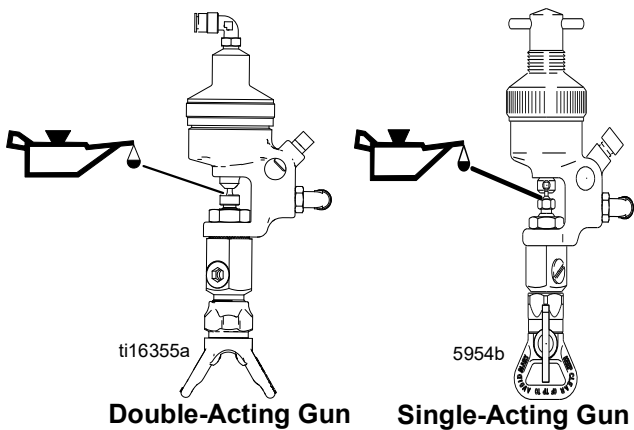

# Service

## Needle, Seat and Packings

To clean or replace the needle, its seat or packings (16, 17, 18), proceed as follows:

1. Perform **Pressure Relief Procedure**, page 5.
2. Remove valve housing:
  - a. Remove cap and spring.
  - b. Loosen nut.

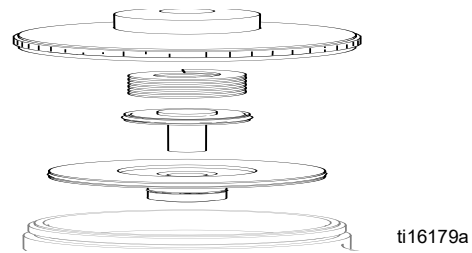

- c. Pull down housing and needle assembly to expose needle shaft.

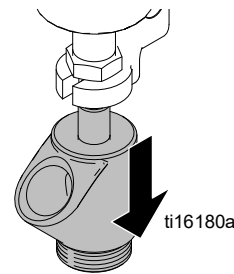

- d. Slide needle through air piston to remove.

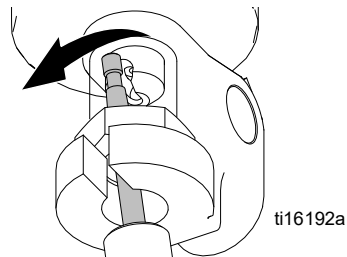

3. Remove RAC guard.

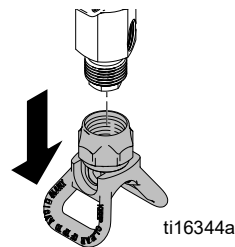

4. Use an open-end wrench to remove valve seat from valve housing.

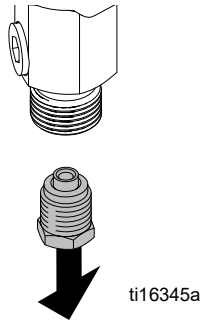

5. Remove gun needle from valve body.

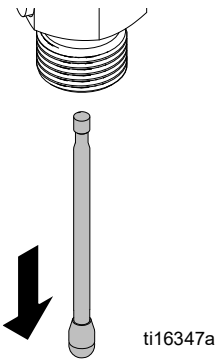

6. Remove packing nut from the valve body.

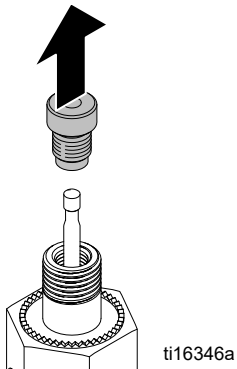

7. Remove packings (16, 17, 18, 20) from valve body.

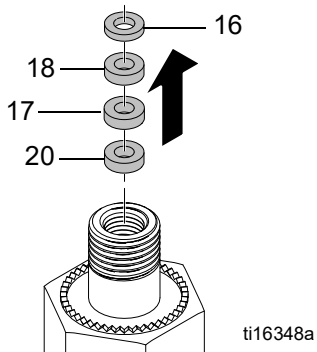

8. Clean all parts.

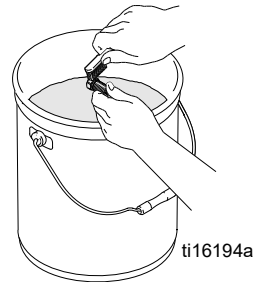

9. Lubricate and install gun needle into valve body.

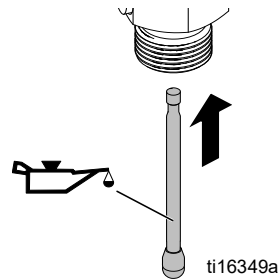

10. Install packings (16, 17, 18, 20) on gun needle.

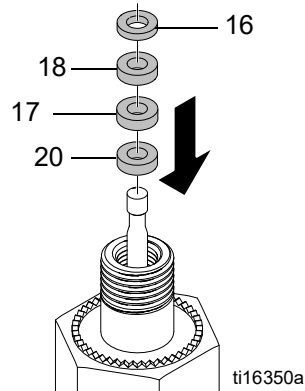

11. Install packing nut and hand-tighten into valve body.

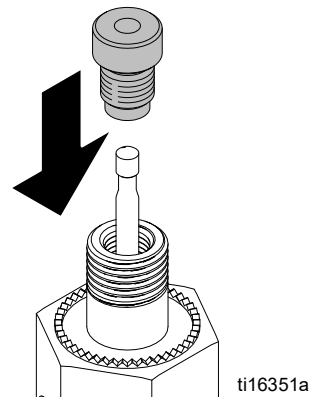

12. Install seat valve into valve housing.

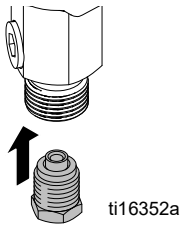

13. Install valve body. Tighten nut.

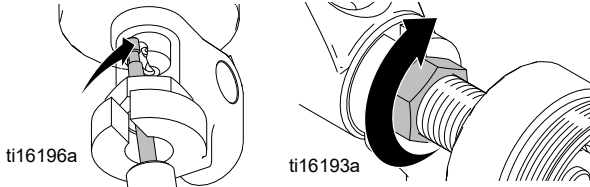

14. Install RAC guard.

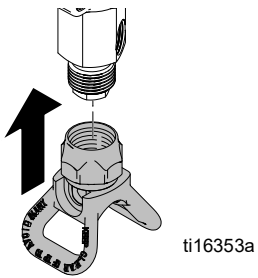

## Air Piston, Spring and Seal

Perform **Pressure Relief Procedure**, page 5. Remove valve as explained on page 6. Remove air cylinder cap, take out spring and pull out the piston. Clean and inspect all parts. Check the piston o-rings (see note 1) carefully. Lubricate all parts with a light waterproof grease and reassemble with valve using new parts as necessary.

**Single-Acting  
238377**

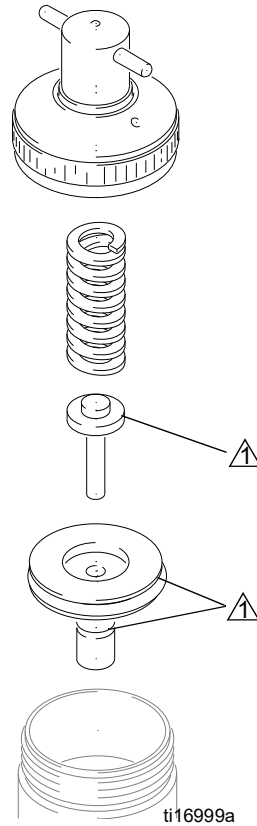

**Double-Acting  
24G980**

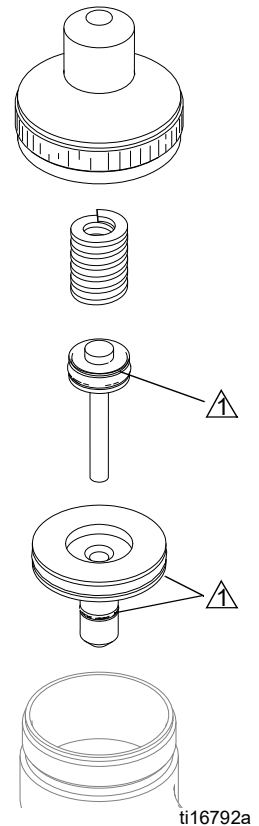



# Replacement Parts and Kits (Double Acting Gun 24G980)

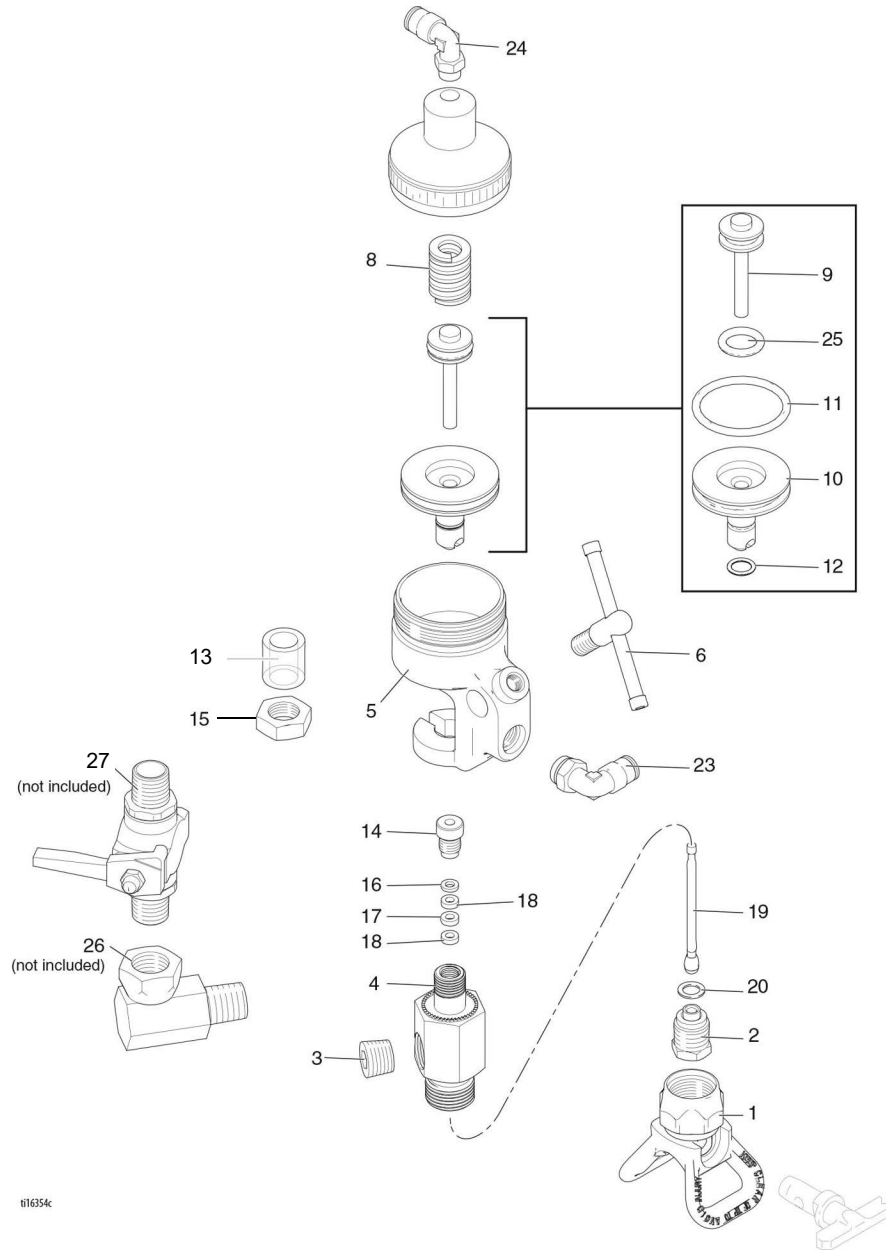

Ref.	Part	Description	Qty.	Ref.	Part	Description	Qty.
1	243161	GUARD, RAC	1	*16	166255	GLAND, packing	1
*2	206987	SEAT, valve	1	*17	166258	PACKING, valve	1
3	101748	PLUG, pipe, 3/8 npt	1	*18	181523	PACKING, valve	2
4	166470	HOUSING, valve	1	*19	220194	NEEDLE, gun	1
5	166847	HOUSING, valve	1	*20	167730	GASKET, copper	1
6	25D347	TOOLESS, handle, gun	1	21	164737	SCREW, adjusting	1
7	16G709	CAP, cylinder	1	22	164736	PIN, handle	1
8	16G764	SPRING, helical compression	1	23	114109	FITTING	1
9	16G169	GUIDE, spring	1	24	112698	FITTING	1
10	164741	PISTON, air	1	25	C20179	O-RING	1
*11	156593	O-RING, nitrile rubber	1	26	207123	UNION, swivel, 90 deg (not included)	
*12	155685	O-RING, nitrile rubber	1	27	24F607	VALVE, ball, 3/8 npt, e-nickel plt (not included)	
*13	191195	TUBE, protection	1				
14	191174	NUT, packing	1				
15	102300	NUT, 9/16-18 nf	1				

\* Included in Repair Kit 238339. Order separately.

# Replacement Parts and Kits (Single Acting Gun 238377)

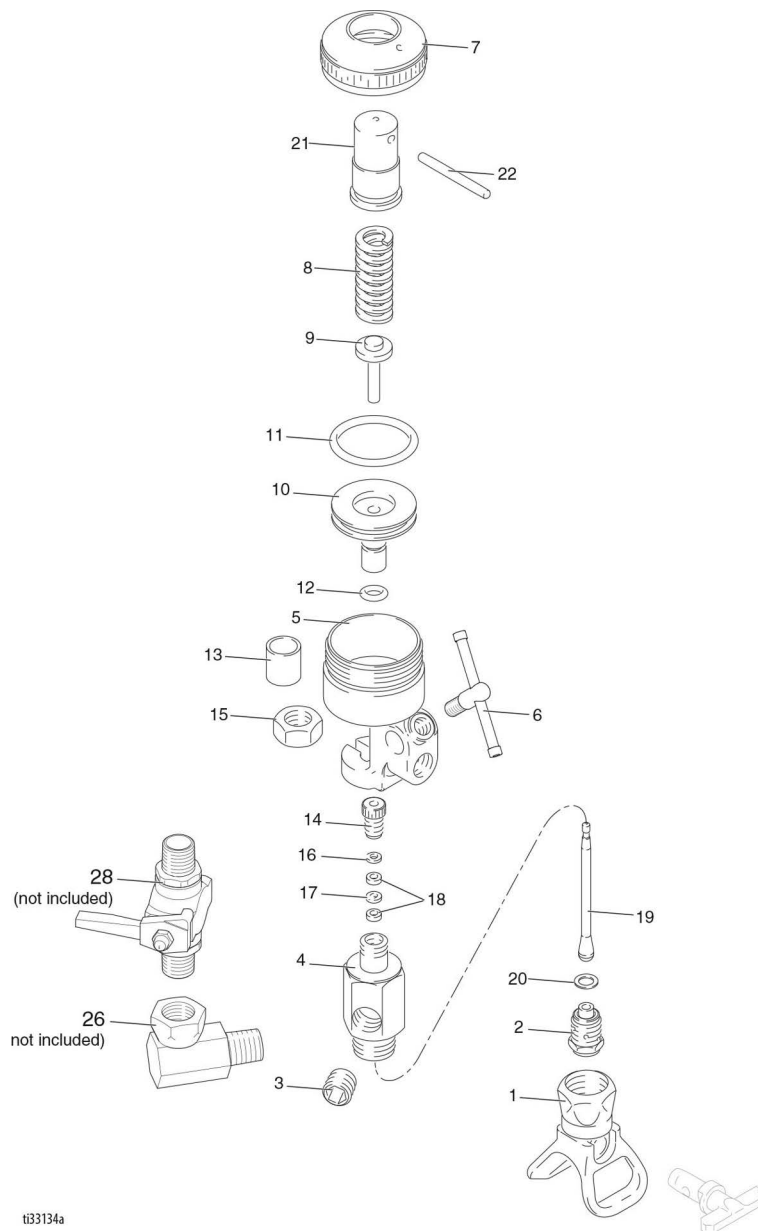

ti33134a

Ref.	Part	Description	Qty.	Ref.	Part	Description	Qty.
1	243161	GUARD, RAC	1	14	191174	NUT, packing	1
*2	206987	SEAT, valve	1	15	102300	NUT, 9/16-18 nf	1
3	101748	PLUG, pipe, 3/8 npt	1	*16	166255	GLAND, packing	1
4	166470	HOUSING, valve	1	*17	166258	PACKING, valve	1
5	166847	HOUSING, valve	1	*18	181523	PACKING, valve	2
6	25D347	TOOLESS, handle, gun	1	*19	220194	NEEDLE, gun	1
7	166848	CAP, air cylinder	1	*20	167730	GASKET, copper	1
8	114060	SPRING, helical compression	1	21	164737	SCREW, adjusting	1
9	164740	GUIDE, spring	1	22	164736	PIN, handle	1
10	164741	PISTON, air	1	26	207123	UNION, swivel, 90 deg (not included)	
*11	156593	O-RING, nitrile rubber	1	28	238694	VALVE, ball (not included)	
*12	155685	O-RING, nitrile rubber	1				
*13	191195	TUBE, protection	1				

\* Included in Repair Kit 238339. Order separately.

# Troubleshooting

Problem	Cause	Solution
Uneven spray pattern	Fluid pressure too low	Increased pressure to pump, or adjust fluid pressure regulator
Spray gun will not stop spraying	Fluid pressure too high	Reduce pressure to pump, or adjust fluid pressure regulator
	Fluid needle binding	Clean, repair
	Piston packing binding	Repair
	Obstructed or worn needle seat	Clean or replace
Spray gun will not spray	Pump not operating	Refer to separate pump manual
	Fluid line clogged	Clear
	Fluid valve closed	Open
	Clogged orifice or needle seat	Clean
	No trigger or actuator air pressure	Check, clean air lines
	Worn or dry piston packings	Replace

# Technical Data

	Single Acting Paint Gun 238377	Double Acting Paint Gun 24G980
Maximum working pressure	3000 psi (210 bar)	
Operating pressure of air actuated trigger:		
Minimum	50 psi (3 bar)	75 psi (5)
Maximum	200 psi (12 bar)	200 psi (12)
Fluid connections	two 3/8 npt(f) ports	
Air connection	1/4 npt(f) air inlet	
Wetted parts	303 & 416 Series Stainless Steel, Tungsten Carbide, Copper, Acetal Homopolymer, Leather	
Operating temperature	32° - 120° F (0° - 49° C)	
Sound pressure level	84.6 dB	
Sound power level	90.9 dB	
*Measurements at 2900 psi (200 bar) per ISO 3744		

# Graco Standard Warranty

Graco warrants all equipment referenced in this document which is manufactured by Graco and bearing its name to be free from defects in material and workmanship on the date of sale to the original purchaser for use. With the exception of any special, extended, or limited warranty published by Graco, Graco will, for a period of twelve months from the date of sale, repair or replace any part of the equipment determined by Graco to be defective. This warranty applies only when the equipment is installed, operated and maintained in accordance with Graco's written recommendations.

This warranty does not cover, and Graco shall not be liable for general wear and tear, or any malfunction, damage or wear caused by faulty installation, misapplication, abrasion, corrosion, inadequate or improper maintenance, negligence, accident, tampering, or substitution of non-Graco component parts. Nor shall Graco be liable for malfunction, damage or wear caused by the incompatibility of Graco equipment with structures, accessories, equipment or materials not supplied by Graco, or the improper design, manufacture, installation, operation or maintenance of structures, accessories, equipment or materials not supplied by Graco.

This warranty is conditioned upon the prepaid return of the equipment claimed to be defective to an authorized Graco distributor for verification of the claimed defect. If the claimed defect is verified, Graco will repair or replace free of charge any defective parts. The equipment will be returned to the original purchaser transportation prepaid. If inspection of the equipment does not disclose any defect in material or workmanship, repairs will be made at a reasonable charge, which charges may include the costs of parts, labor, and transportation.

**THIS WARRANTY IS EXCLUSIVE, AND IS IN LIEU OF ANY OTHER WARRANTIES, EXPRESS OR IMPLIED, INCLUDING BUT NOT LIMITED TO WARRANTY OF MERCHANTABILITY OR WARRANTY OF FITNESS FOR A PARTICULAR PURPOSE.**

Graco's sole obligation and buyer's sole remedy for any breach of warranty shall be as set forth above. The buyer agrees that no other remedy (including, but not limited to, incidental or consequential damages for lost profits, lost sales, injury to person or property, or any other incidental or consequential loss) shall be available. Any action for breach of warranty must be brought within two (2) years of the date of sale.

**GRACO MAKES NO WARRANTY, AND DISCLAIMS ALL IMPLIED WARRANTIES OF MERCHANTABILITY AND FITNESS FOR A PARTICULAR PURPOSE, IN CONNECTION WITH ACCESSORIES, EQUIPMENT, MATERIALS OR COMPONENTS SOLD BUT NOT MANUFACTURED BY GRACO.** These items sold, but not manufactured by Graco (such as electric motors, switches, hose, etc.), are subject to the warranty, if any, of their manufacturer. Graco will provide purchaser with reasonable assistance in making any claim for breach of these warranties.

In no event will Graco be liable for indirect, incidental, special or consequential damages resulting from Graco supplying equipment hereunder, or the furnishing, performance, or use of any products or other goods sold hereto, whether due to a breach of contract, breach of warranty, the negligence of Graco, or otherwise.

## FOR GRACO CANADA CUSTOMERS

The Parties acknowledge that they have required that the present document, as well as all documents, notices and legal proceedings entered into, given or instituted pursuant hereto or relating directly or indirectly hereto, be drawn up in English. Les parties reconnaissent avoir convenu que la rédaction du présente document sera en Anglais, ainsi que tous documents, avis et procédures judiciaires exécutés, donnés ou intentés, à la suite de ou en rapport, directement ou indirectement, avec les procédures concernées.

# Graco Information

For the latest information about Graco products, visit [www.graco.com](http://www.graco.com).

For patent information, see [www.graco.com/patents](http://www.graco.com/patents).

**TO PLACE AN ORDER**, contact your Graco distributor or call 1-800-690-2894 to identify the nearest distributor.

*All written and visual data contained in this document reflects the latest product information available at the time of publication. Graco reserves the right to make changes at any time without notice.*

For patent information, see [www.graco.com/patents](http://www.graco.com/patents)  
Original instructions. This manual contains English. MM 308613

**Graco Headquarters:** Minneapolis  
**International Offices:** Belgium, China, Japan, Korea

**GRACO INC. AND SUBSIDIARIES P.O. BOX 1441 MINNEAPOLIS, MN 55440-1441 USA**

**Copyright 2010, Graco Inc. All Graco manufacturing locations are registered to ISO 9001**

[www.graco.com](http://www.graco.com)  
Revised N, July 2022